

JK **Gelius**

IMPÉRIO
roupeiro | ropero | wardrobe

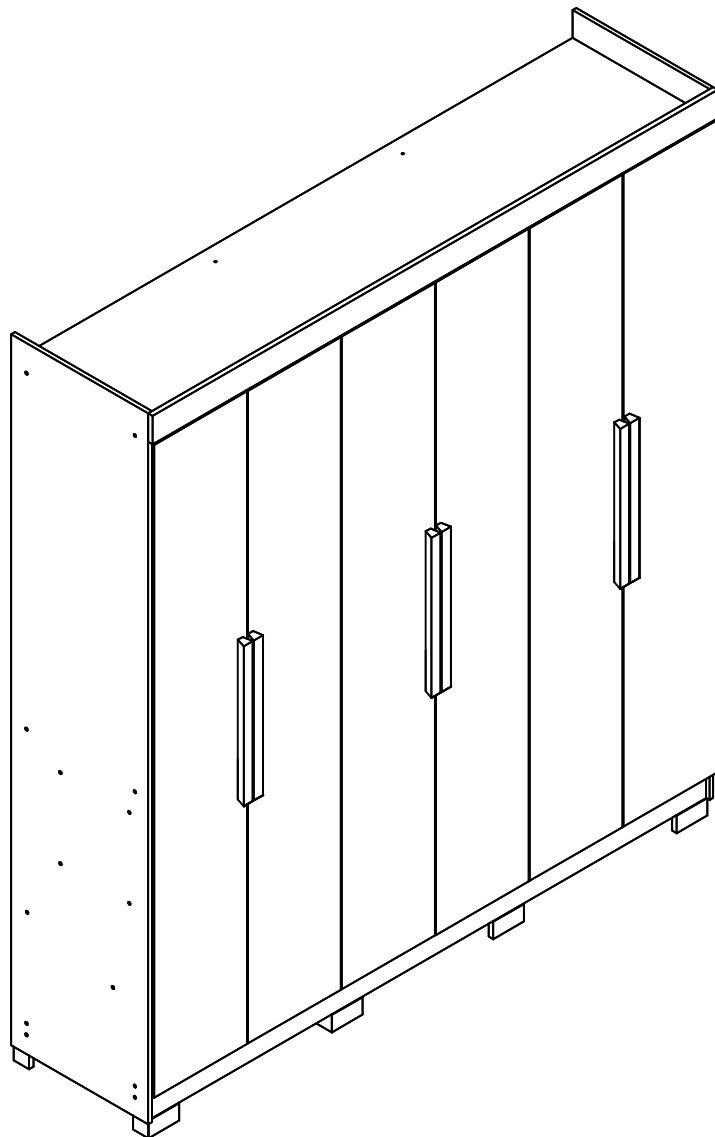

Versão Portas Mdf

Versão Portas Reflecta

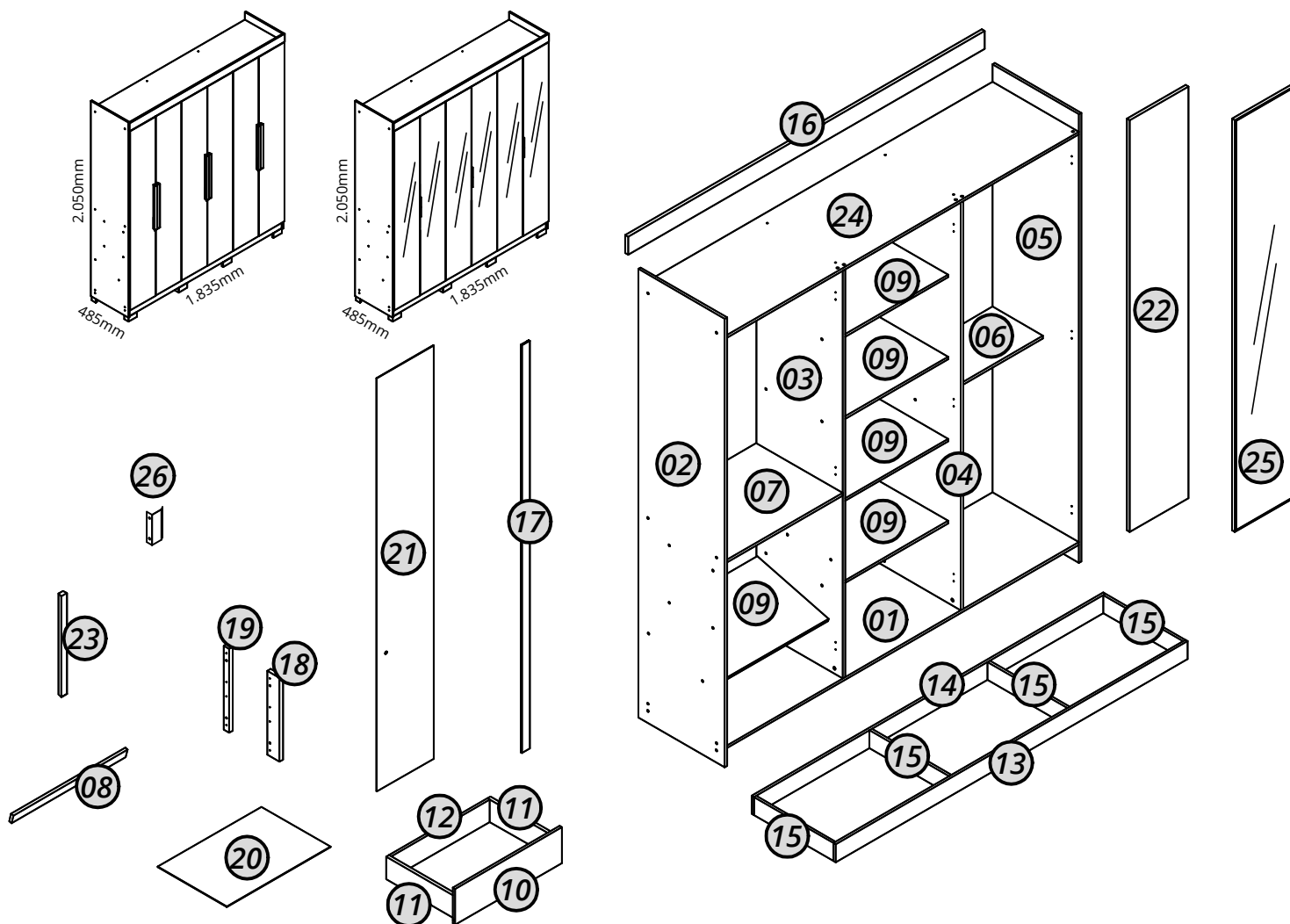

Nº	Cód.	Peças	Piezas	Parts	Medida / Size	Qtd.	Vol.
01	08302	Base	Base	Base	1812x445x12	01	02
02	08303	Lateral esquerda	Lateral izquierda	Left side	2000x445x12	01	01
03	08305	Divisória esquerda	División izquierda	Left division	1818x445x12	01	02
04	08306	Divisória direita	División derecha	Right division	1818x445x12	01	02
05	08304	Lateral direita	Lateral derecha	Right side	2000x445x12	01	01
06	08307	Prateleira menor	Estante menor	Smaller shelf	595x260x12	01	02
07	08308	Prateleira maior	Estante más mayor	Bigger shelf	595x435x12	01	01
08	08309	Regua prateleira	Regla del estante	Shelf ruler	589x40x12	01	01
09	08310	Prateleira media	Estante promedio	Average shelf	595x380x12	05	01
10	08311	Frente de gaveta	Frente del cajon	Front off drawer	550x160x12	02	01
11	08312	Lateral de gaveta	Lateral del cajon	Side off drawer	350x100x12	04	01
12	08313	Contra fundo gaveta	Trasero del cajon	Rear off drawer	510x100x12	02	01
13	08314	Rodape frontal	Rodapie frontal	Lower front crossbar	1812x80x12	01	02
14	08315	Rodape traseiro	Rodapie trasero	Lower rear crossbar	1812x80x12	01	02
15	08316	Trava rodape	Traba del rodapie	Smaller crossbar	410x80x12	04	02
16	08317	Moldura	Marco	Frame	1836x80x15	01	01
17	08318	Perfil H	Perfil H	Profile H	1818x40x6	03	01
18	08319	Distanciador frontal	Espaciador frontal	Front spacer	374x63x18	02	01
19	08320	Distanciador traseiro	Espaciador trasero	Rear spacer	374x28x18	02	01
20	08321	Fundo de gaveta	Fondo del cajone	Bottom off the drawer	534x355x2,5	02	01
21	08322	Fundo traseiro furado	Fondo trasero agujereado	Holed rear bottom	1842x293x2,5	06	01
22	*	Portas	Puertas	Doors	1836x302x15	06	01
23	*	Puxador	Tirador	Handle	450x30x20	06	01
24	09282	Tampo	Cubierta	Top	1812x445x12	01	02
25	*	Porta reflecta	Puerta reflectante	Reflective door	1836x302x18	06	01
26	*	Kit puxador (Versão reflecta)	Kit tirador (Versión reflectante)	Kit handle (Reflective version)	*	01	01

ATENÇÃO: Este manual é utilizado para diferentes versões deste produto. Por isso, algumas etapas de montagem, peças ou acessórios descritos podem não se aplicar à versão adquirida. Caso você identifique itens que não correspondam ao seu modelo (como espelho, pés, LED, entre outros), desconsidere essas instruções e componentes. A presença desses itens no manual ou na embalagem não configura erro ou falta de peças.

Recorte aqui e guarde seu certificado de garantia!

Certificado de garantia

A Gelius Indústria de Móveis confia na qualidade de seus produtos e por isso o garante pelo prazo de 90 dias para defeitos de fabricação em condições normais de uso.

Resultarão nula a garantia e sem efeito a cobertura, se o produto, (incluindo vidros e ou espelhos que o compõe):

- sofrer dano provocado por acidente, agente da natureza.
- uso indevido ou maus tratos como arrastar, subir em cima, colocar produtos com excesso de peso).
- não utilizado para os fins a que se destina.
- conter manchas provocadas por uso de produtos químicos em sua limpeza.
- excesso de umidade ou água.

Ao detectar qualquer defeito em seu móvel, entre em contato com a loja onde foi efetuada a compra. A comprovação de que o móvel a ser consertado ou substituído encontra-se dentro do prazo de garantia é de total responsabilidade do fabricante e deve ser feita mediante a apresentação desse certificado corretamente preenchido e sem rasuras ou resalvas.

Cuidados com seu móvel Gelius!

- para limpeza do seu móvel, utilize apenas pano macio e seco.
- jamais limpe-o com palha de aço, álcool ou qualquer outro produto químico ou abrasivos, óleos de peroba ou produtos do gênero.
- evite deixá-lo sob raios solares ou chuva.
- ao transportar o seu móvel Gelius, prenda-o firmemente para que não ocorra quedas indesejáveis.

Seguindo corretamente as informações acima, você conservará por muito mais tempo o seu móvel Gelius!

GARANTIA DO CLIENTE:

Cliente: _____

Rua: _____ Nº: _____ Bairro: _____

Cidade: _____ UF: _____ Loja onde comprou: _____

Data da compra: ____/____/____ Nota Fiscal: _____

Data da reclamação na loja: ____/____/____

Defeito constante: _____

Recomendações | Recomendaciones | Recommendations

Atenção
 Atención
 Attention

Este produto deve ser montado por um profissional.

Este producto debe ser ensamblado por un profesional.

This product must be assembled by a professional.

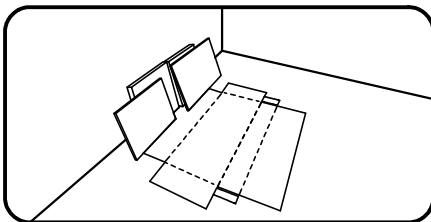

Antes de começar a montagem prepare o ambiente, deixando-o completamente limpo e com bom espaço para iniciar o trabalho. Utilize o papelão da própria embalagem para separar e apoiar as peças retiradas da caixa.

Antes de comenzar el montaje preparar el ambiente, dejándolo completamente limpio y con buen espacio para comenzar el trabajo. Utilice el cartón de la embalaje para separar y apoyar las piezas desmontadas de las cajas.

Prepare the room before starting the assembly, leaving it completely clean and the area in good condition to start the work. Use the cardboard of the packaging to separate and support the parts removed from the boxes.

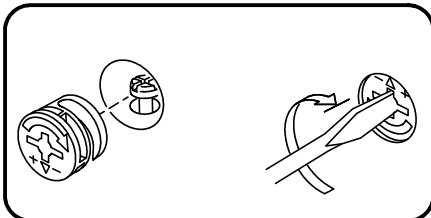

Como usar o acessório Pino e Tambor Minifix (quando utilizado no produto).

Como usar el herraje Pino y Tambor Minifix (cuando se usa en el producto).

How to use the Minifix Set (when used in the product).

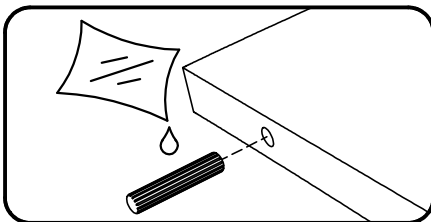

Aplicar cola nas cavilhas de madeira (quando utilizado no produto).

Aplicar pegamento a las clavijas de madera (cuando se usa en el producto).

Apply glues to the wooden dowels (when used in the product).

Ferramentas recomendadas para montagem | Herramientas de montaje recomendadas | Recommended tools

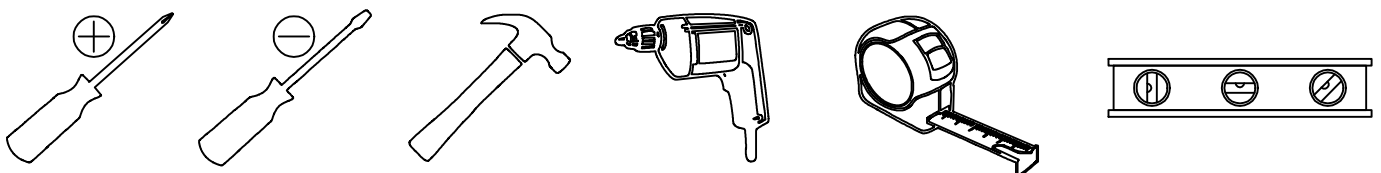

Acessórios e ferragens | Herrajes | Hardware

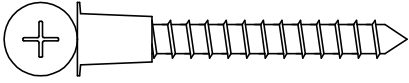

A — cód. 30017779 — 036 un.



B — cód. 30014538 — 278 un.

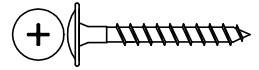

C — cód. 30000843 — 012 un.

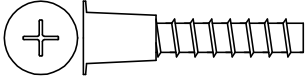

D — cód. 30018169 — 008 un.



E — cód. 30010241 — 004 un.

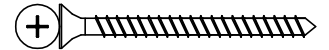

F — cód. 30001098 — 024 un.



G — cód. 30014537 — 036 un.

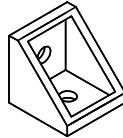

H — cód. 30015224 — 021 un.

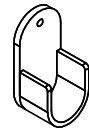

I — cód. 30001188 — 006 un.

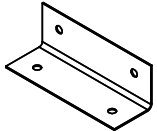

J — cód. 30003829 — 018 un.



K — cód. 30000783 — 140 un.

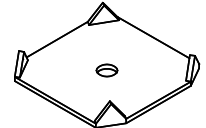

L — cód. 30001164 — 024 un.

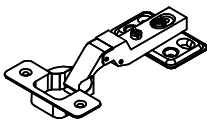

M — cód. 30014846 — 018 un.

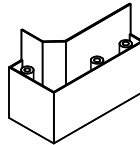

N — cód. 30018075 — 008 un.

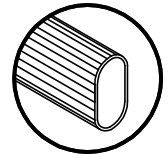

O — cód. 30019850 — 003 un.



P — cód. 30014656 — 003 un.

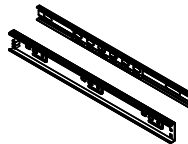

Q — cód. 30013843 — 002 un.

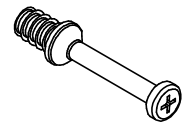

R — cód. 30006753 — 008 un.

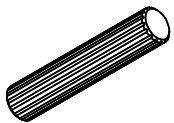

S — cód. 30000770 — 008 un.

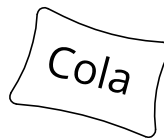

T — cód. 30000790 — 001 un.



U — cód. 30001073 — 008 un.



V — cód. 30007801 — 010 un.

Cola

T — cód. 30000790 — 001 un.

01

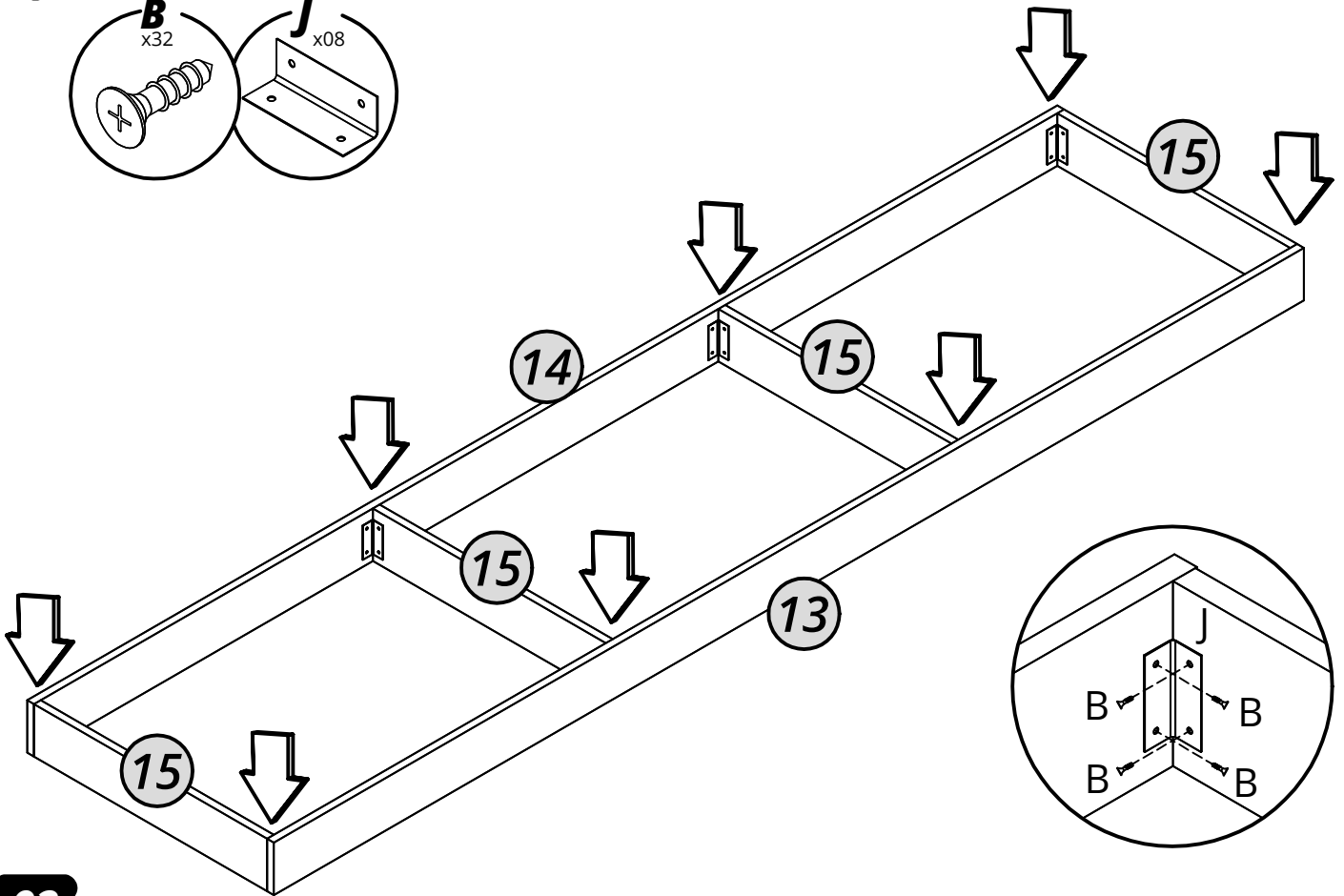
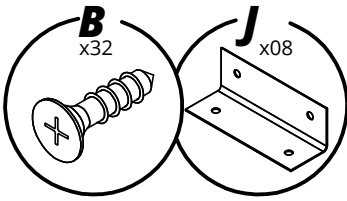

02

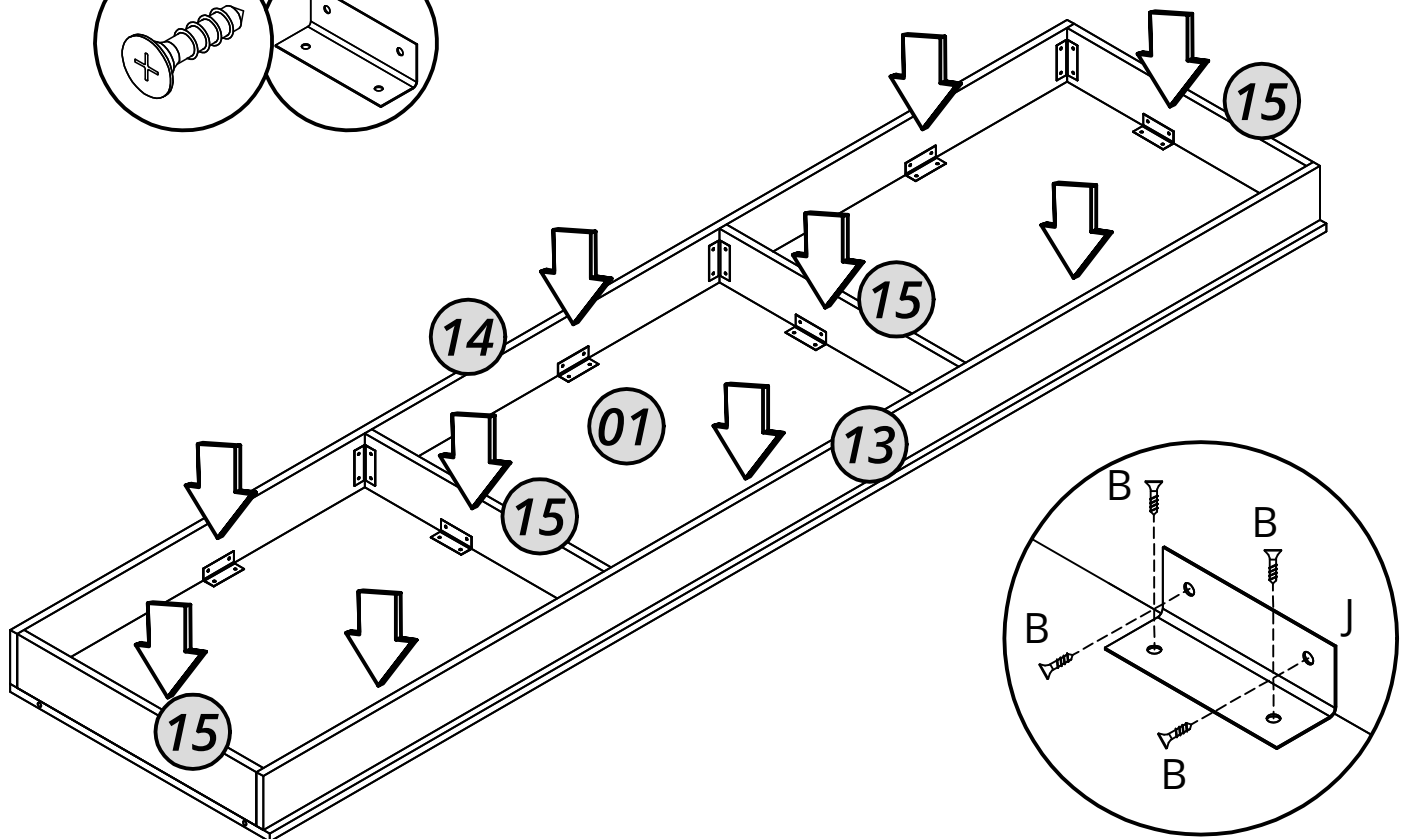
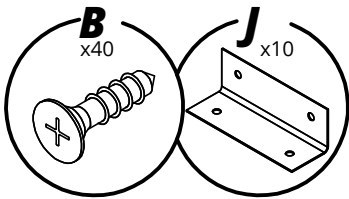

05

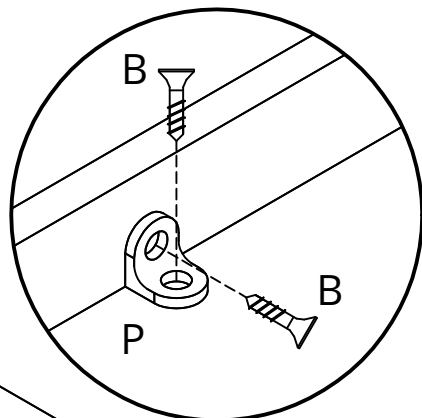
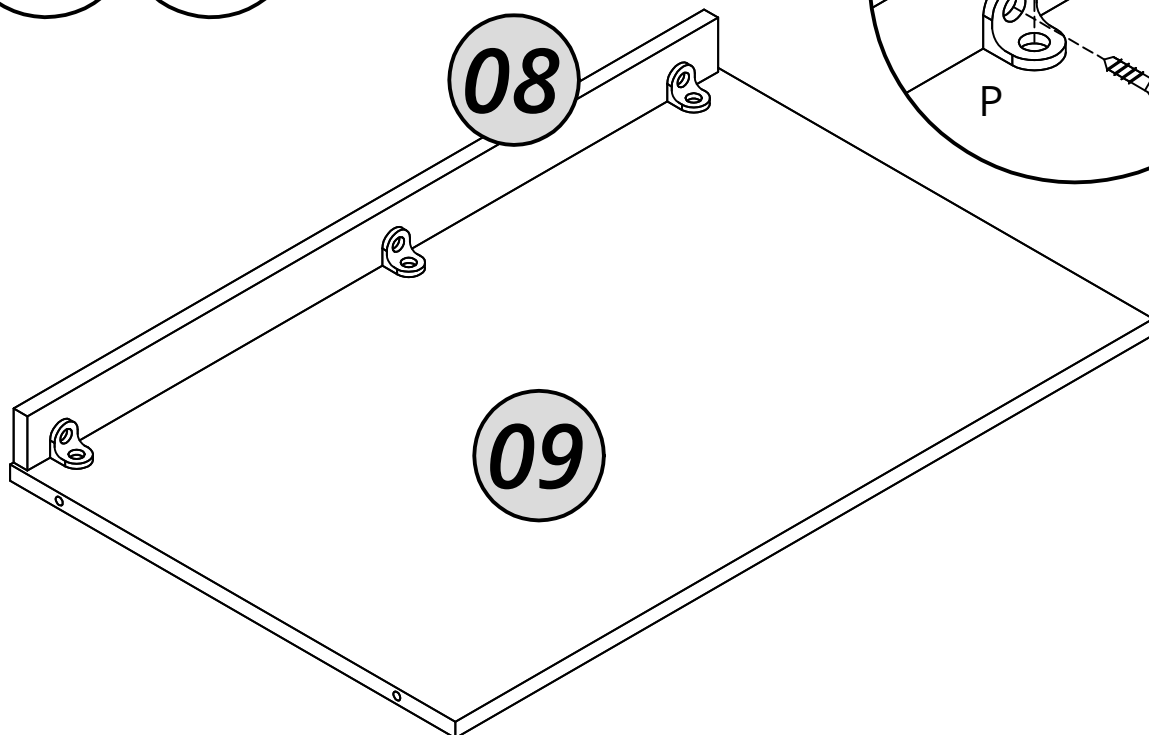
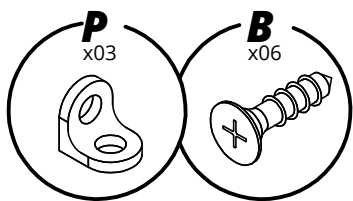

06

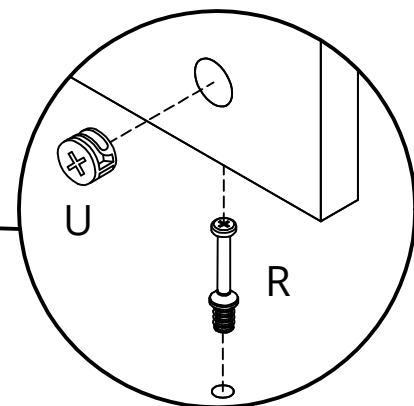
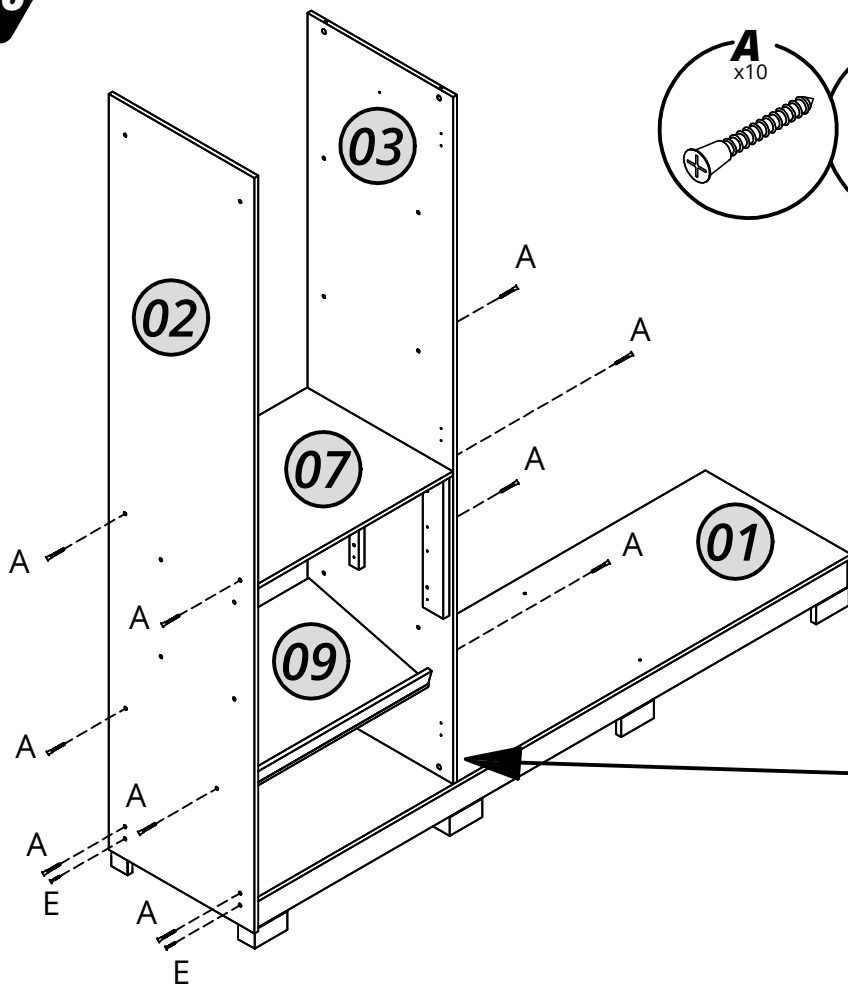
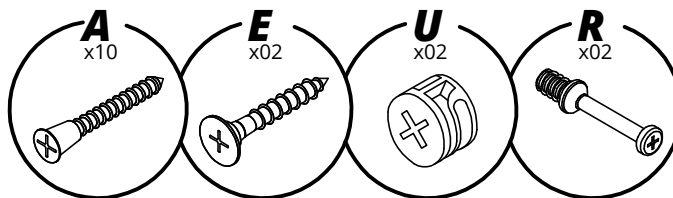

07

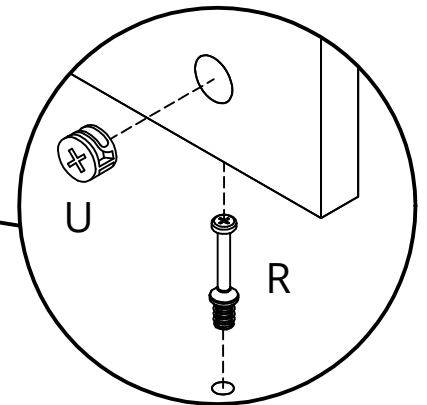
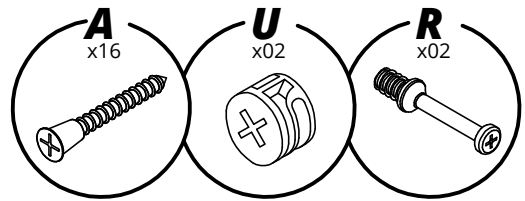
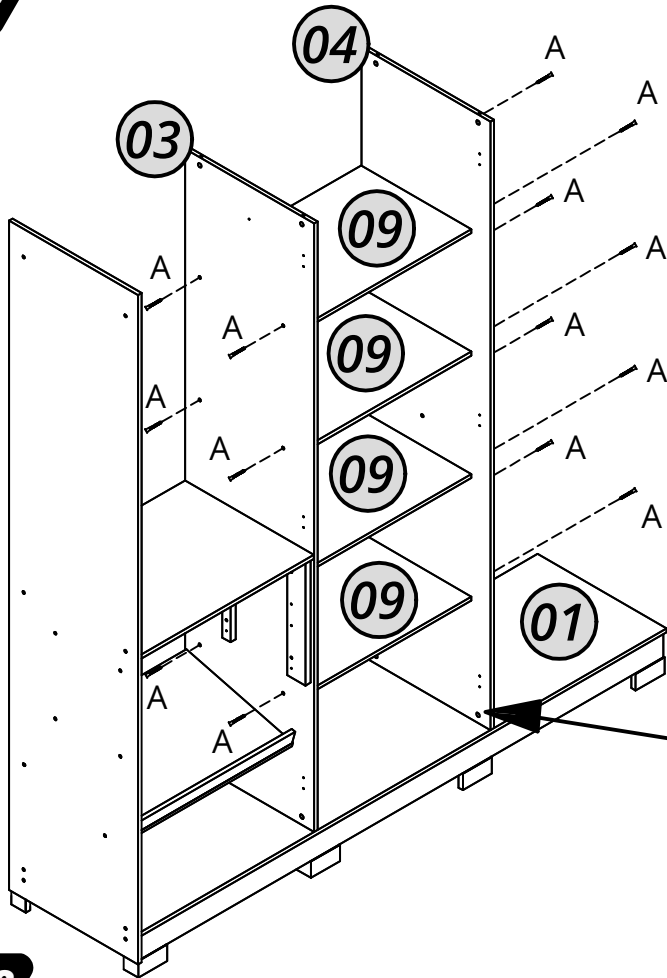

08

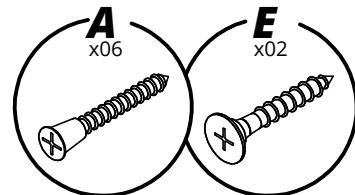
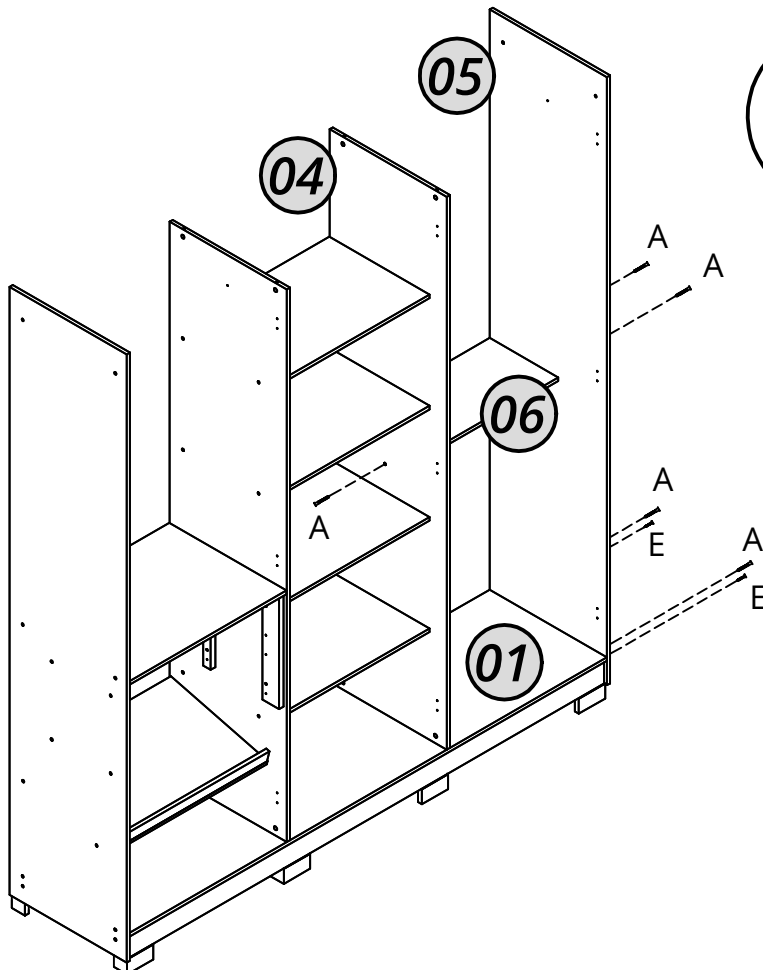

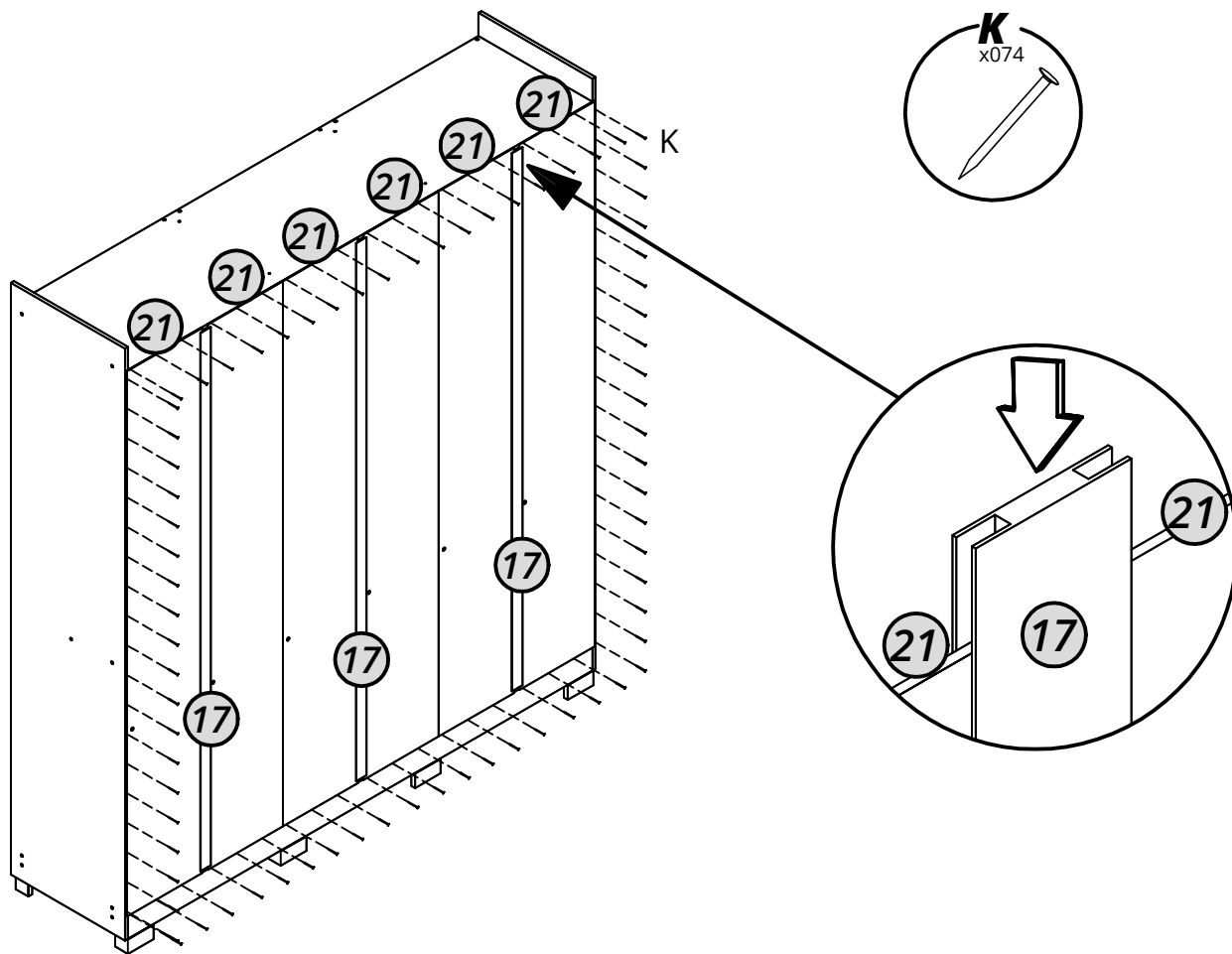
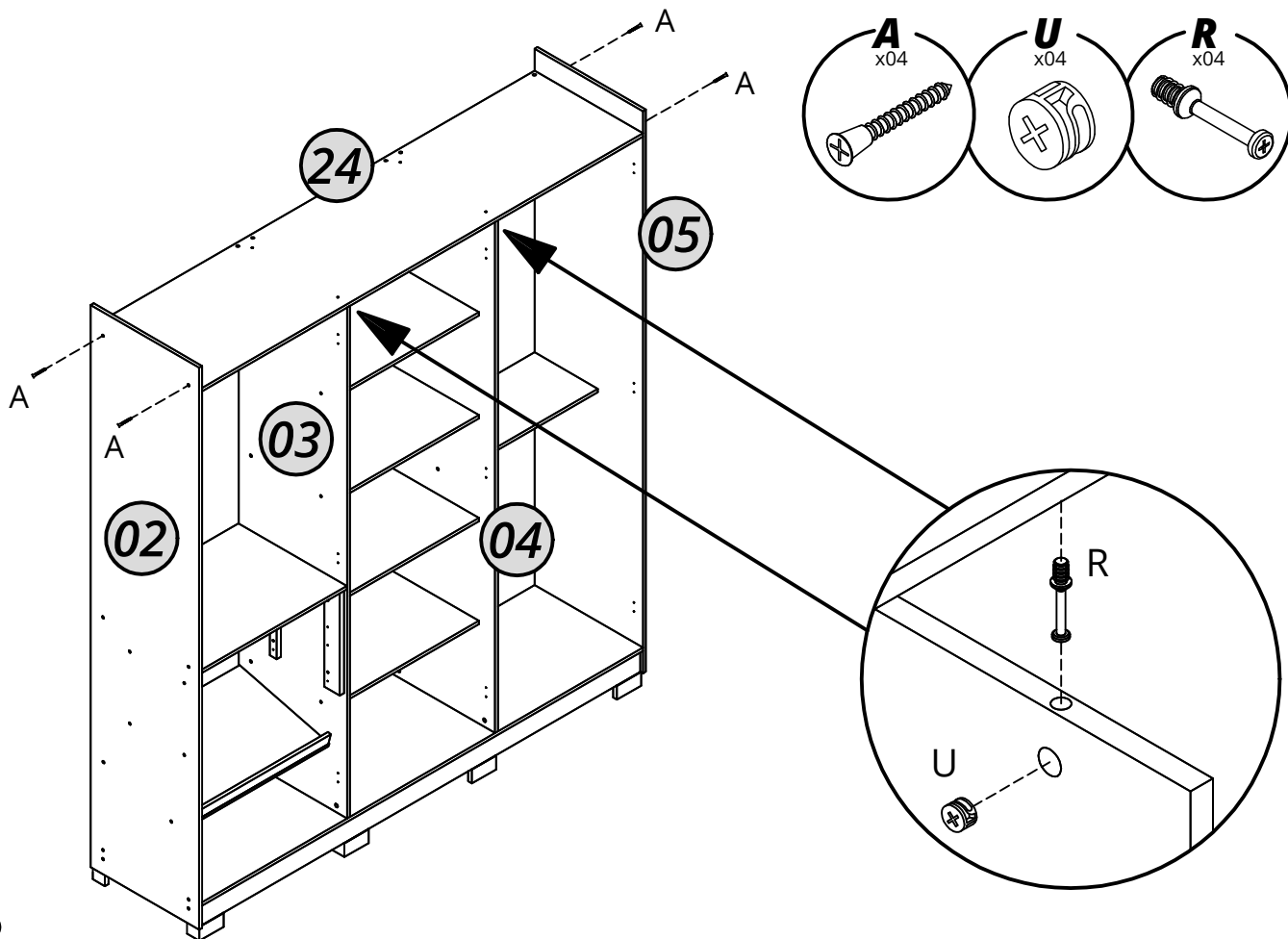

11

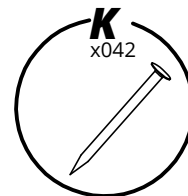
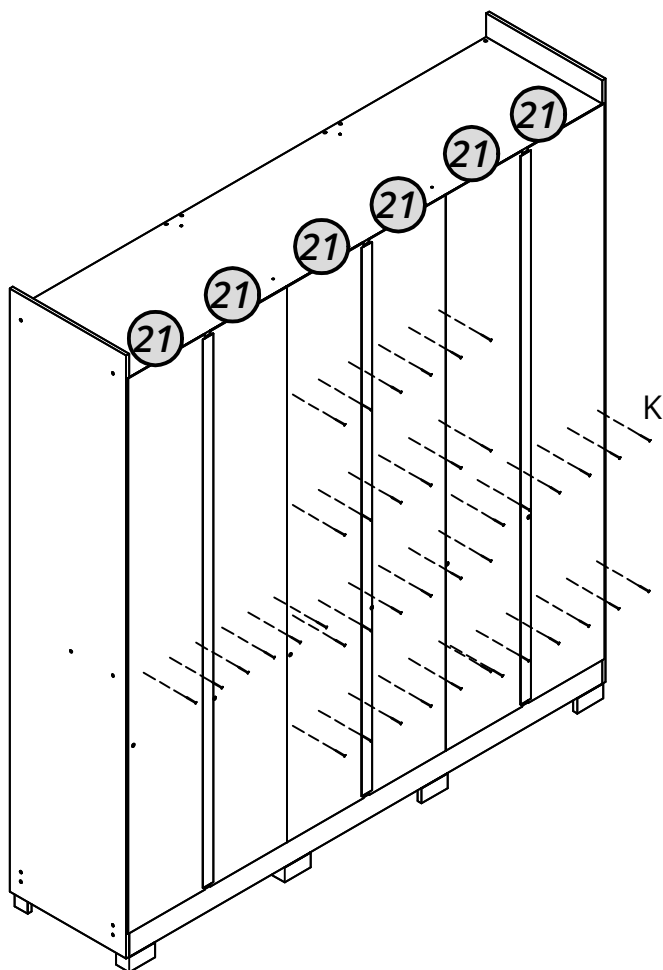

Atenção: Orientamos também,
pregar os fundos nas prateleiras.

12

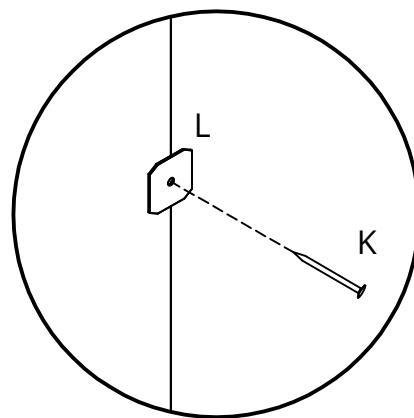
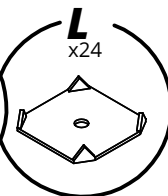
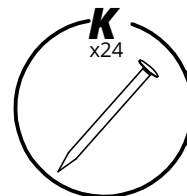
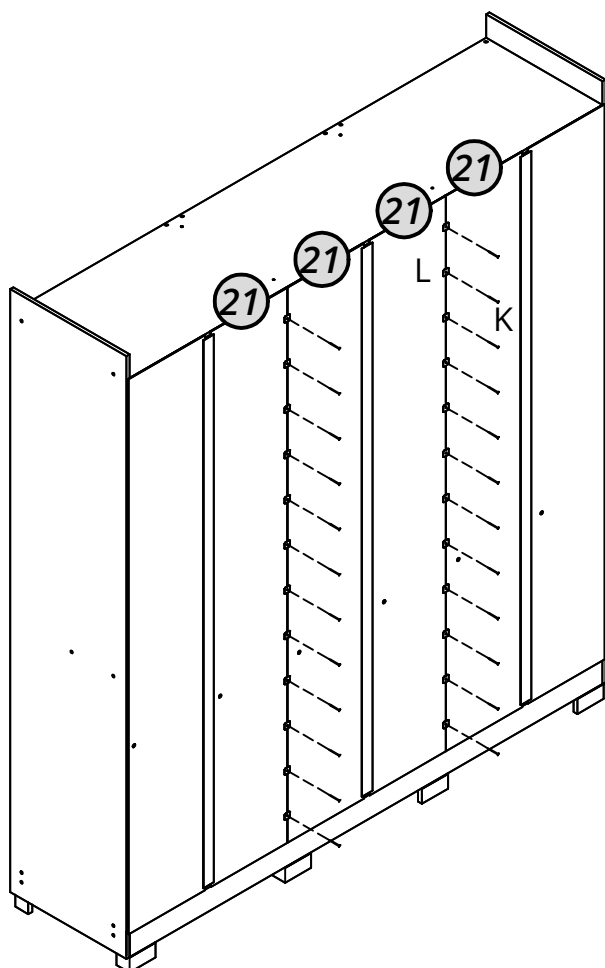

13

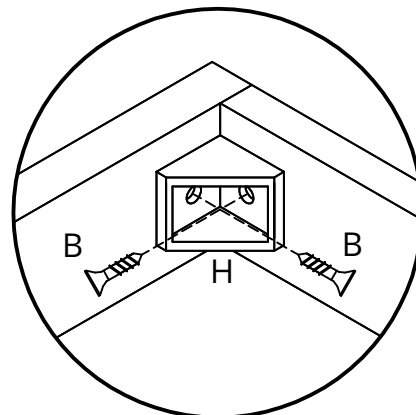
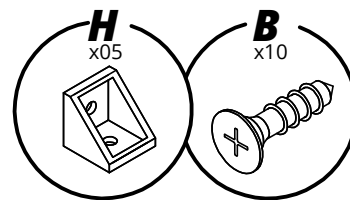
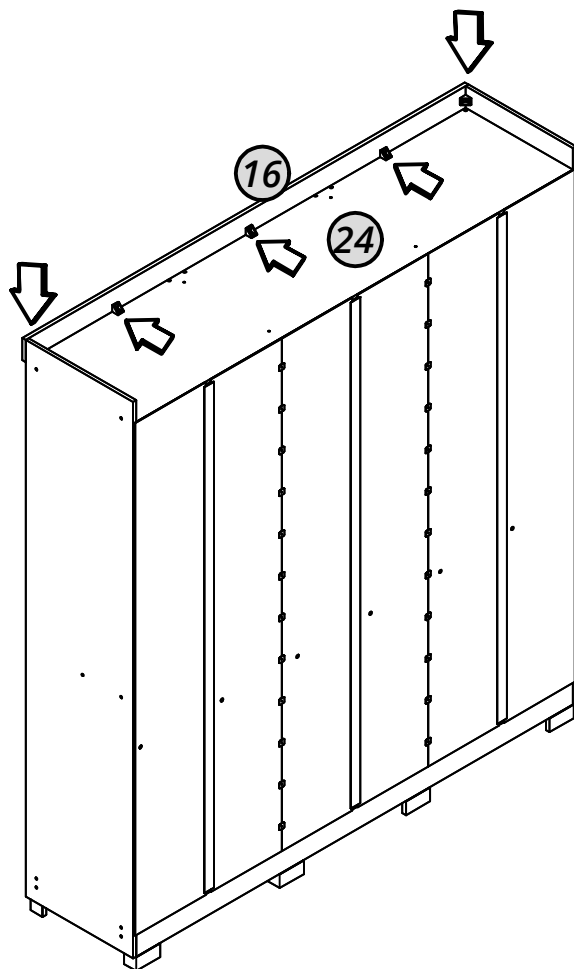

14

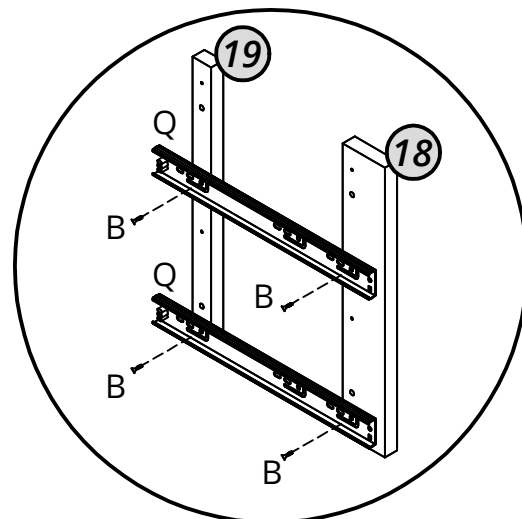
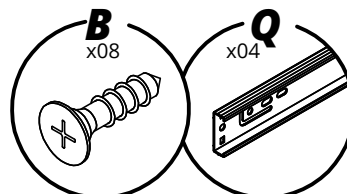
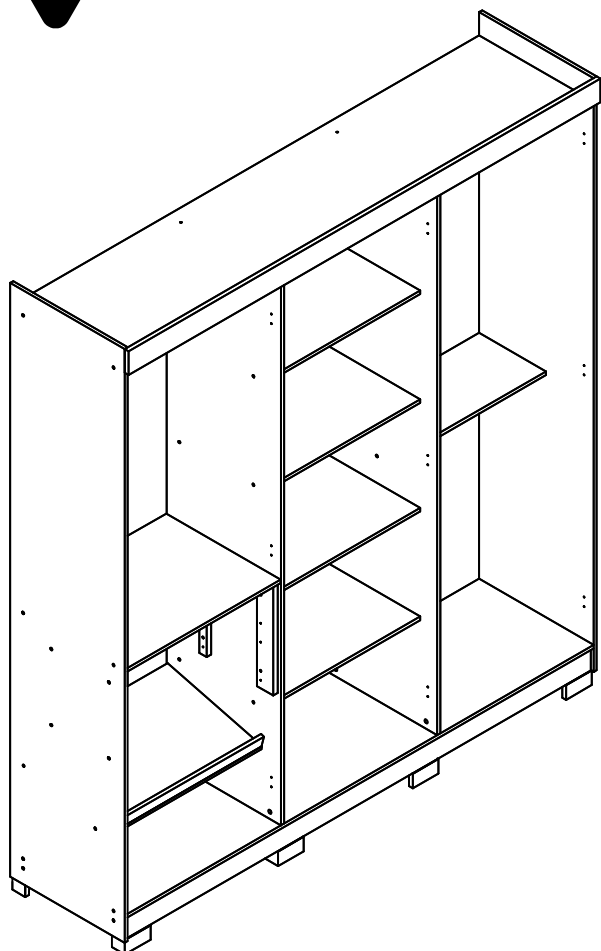

15

Atenção: Utilize cola na cavilha.

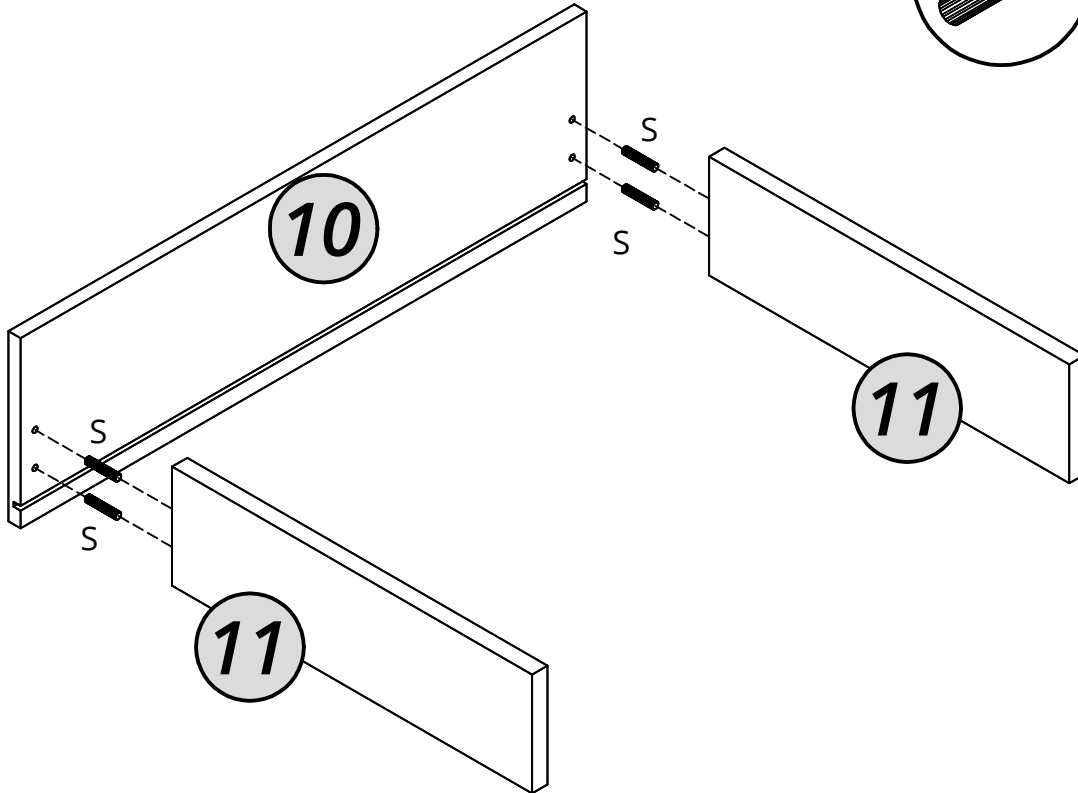
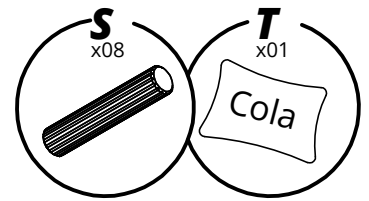

16

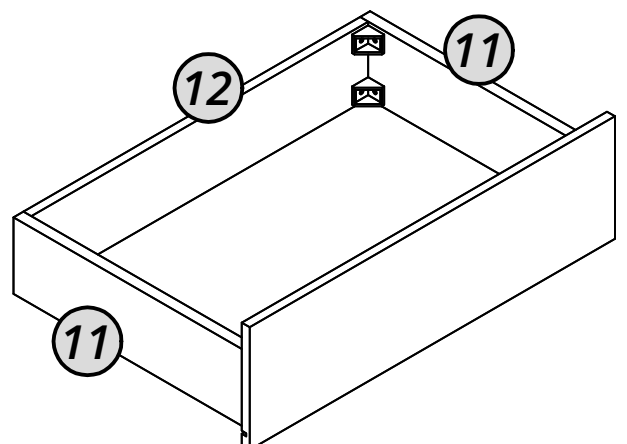
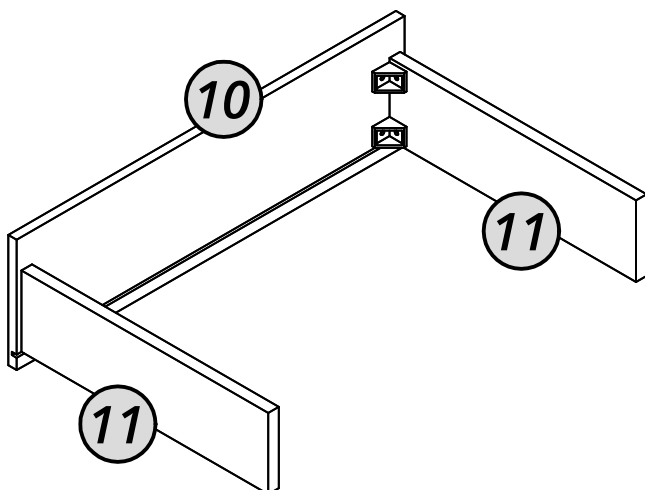
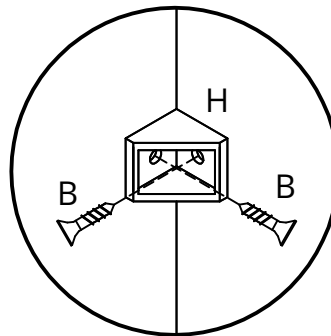
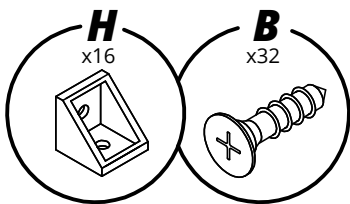

17

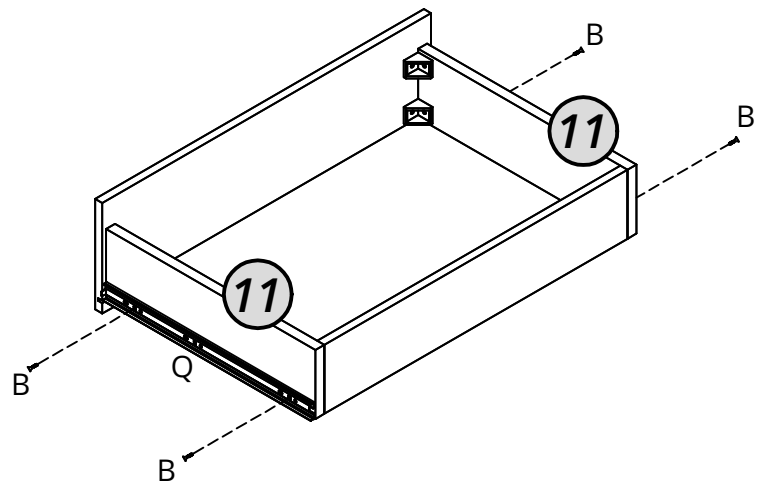
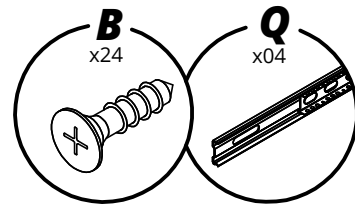
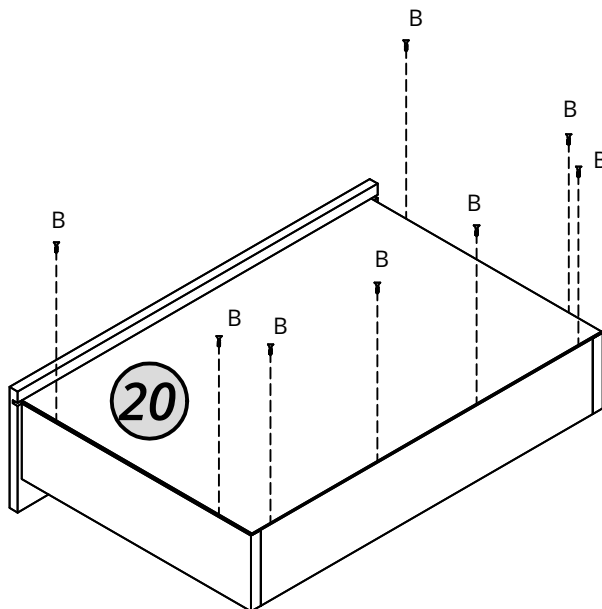

18

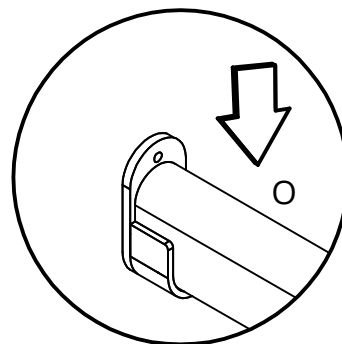
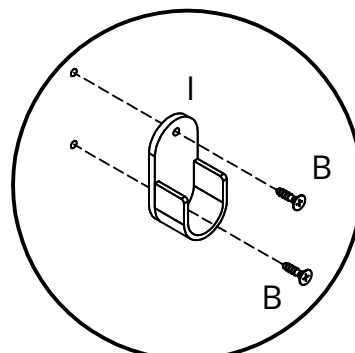
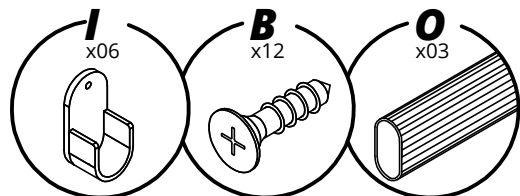
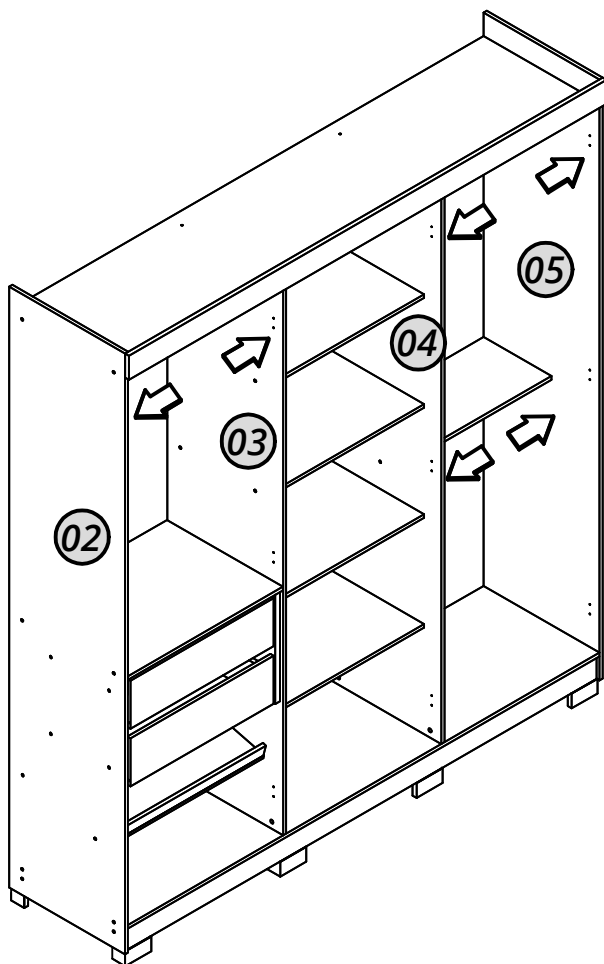

19

INSTALAÇÃO DO KIT LED

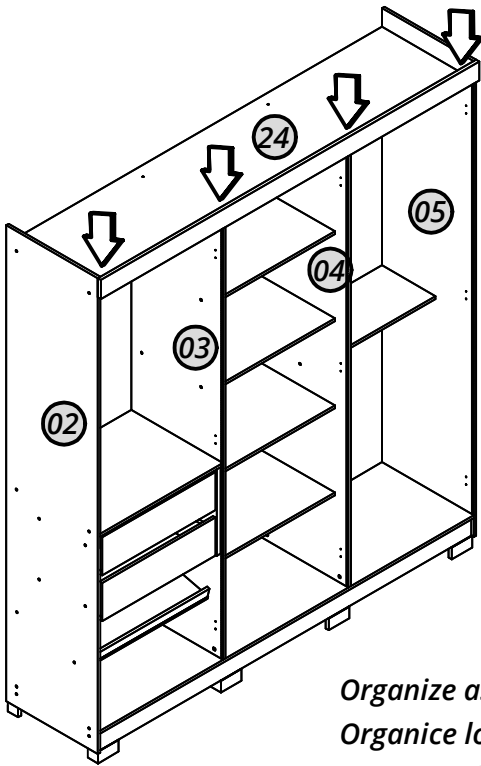

Passe a fita de LED pela furação do tampo (24), cole-a nas laterais (02 e 05) e também nas divisórias (03 e 04). Em seguida, fixe o botão no local desejado.

Pase la tira de LED por el orificio del tablero (24), y pégala en los laterales (02 y 05), así como en los divisores (03 y 04). Luego, fije el botón en el lugar deseado.

Pass the LED strip through the hole in the top panel (24), and stick it to the sides (02 and 05) as well as the dividers (03 and 04). Then, attach the button in the desired location.

Organize as fiações com os acessórios B e V.
 Organice los cableados con los accesorios B y V.
 Organize the wiring with accessories B and V.

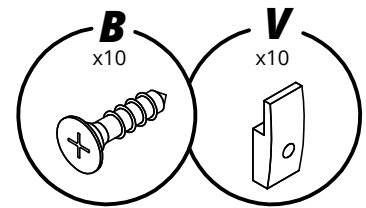

20

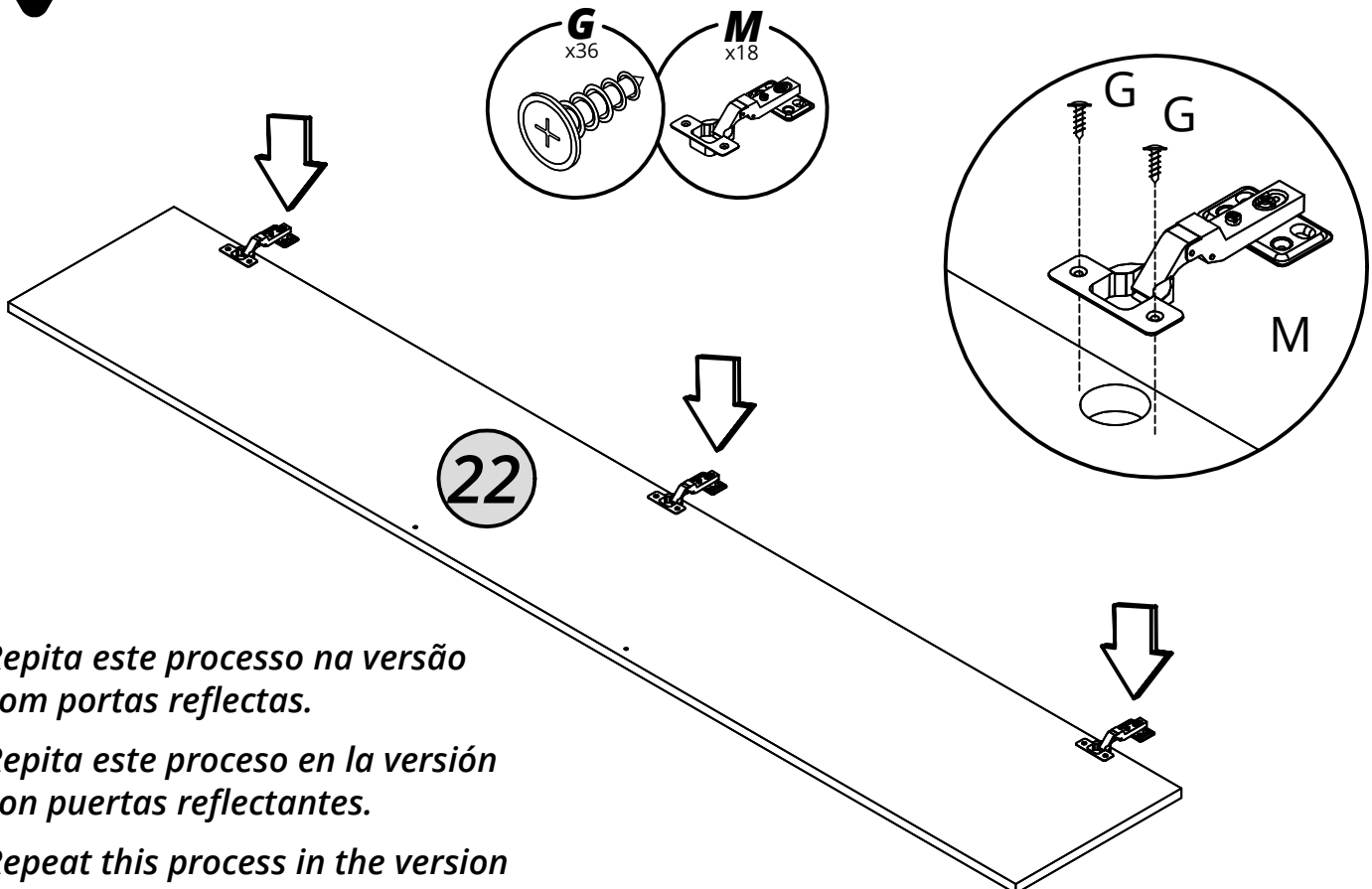

Repita este processo na versão com portas reflectas.

Repita este proceso en la versión con puertas reflectantes.

Repeat this process in the version with reflective doors.

21

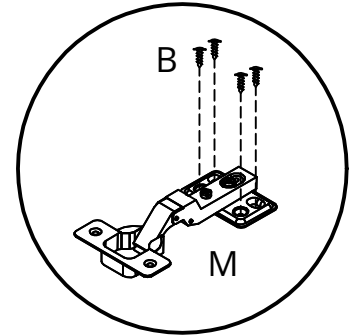
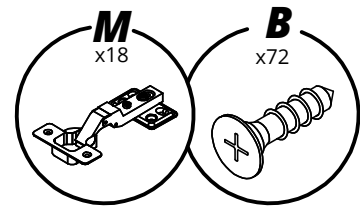
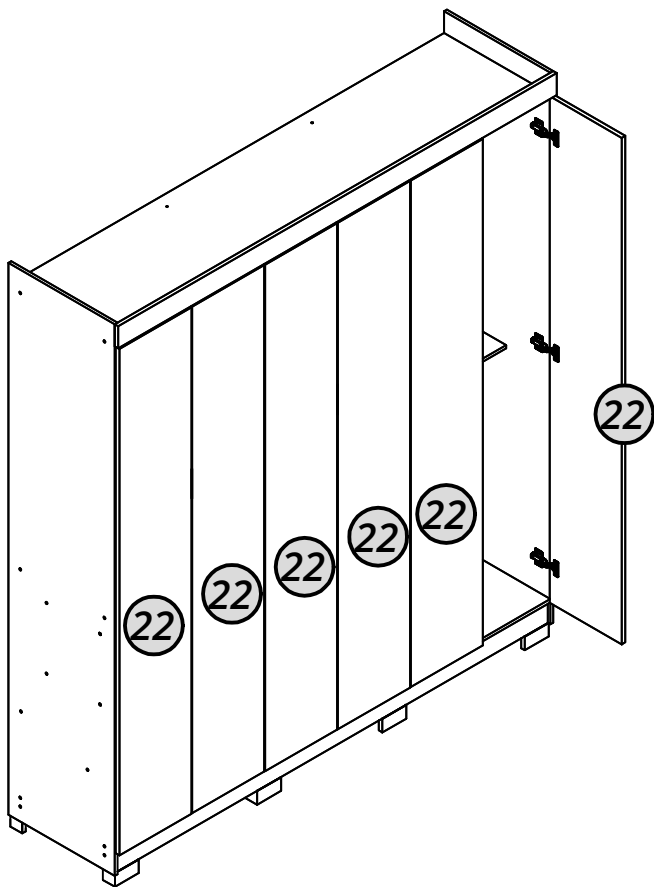

Repita este processo na versão com portas reflectas.

Repita este proceso en la versión con puertas reflectantes.

Repeat this process in the version with reflective doors.

22

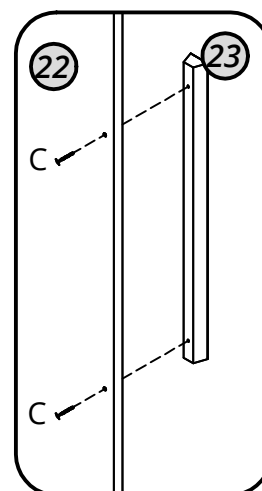
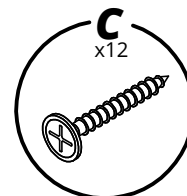
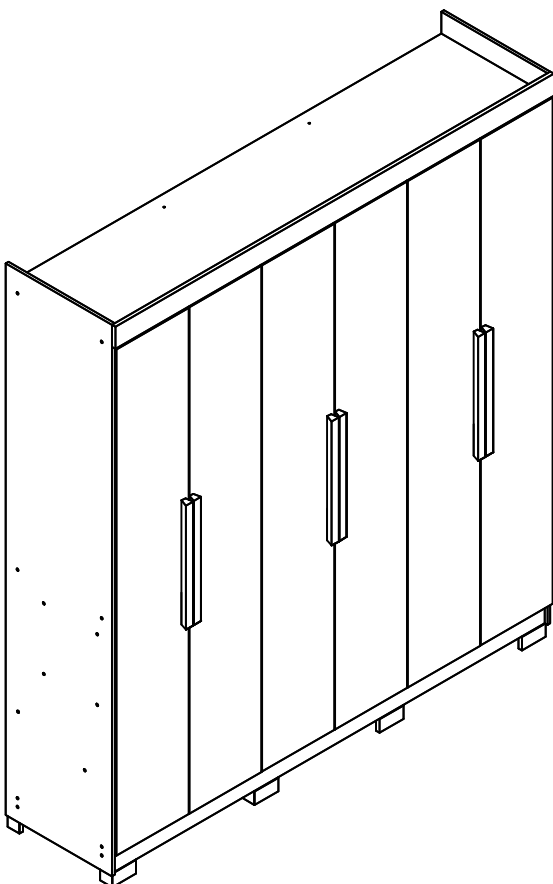

23

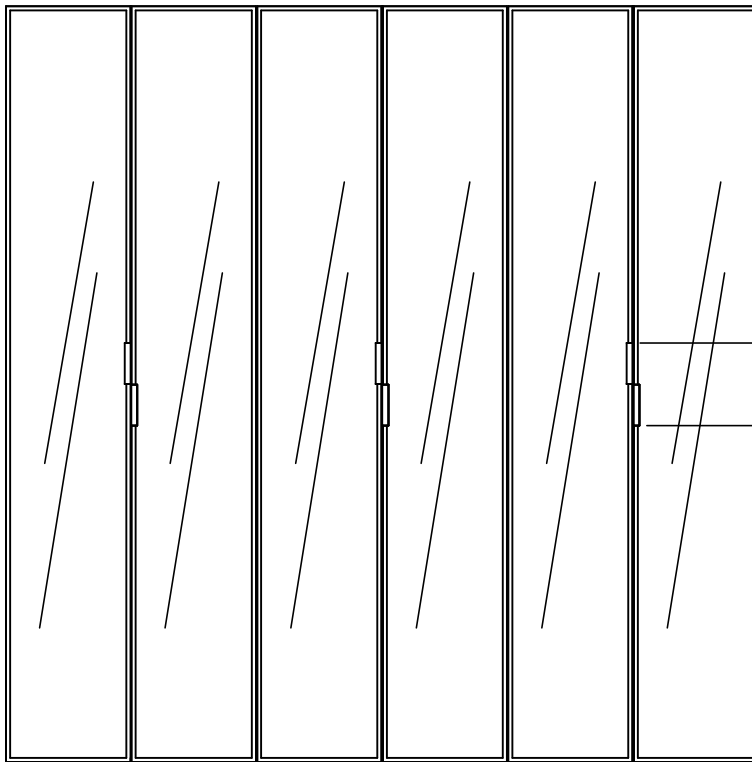

Medidas em milímetros
 Medidas en milímetros
 Measurements in millimeters

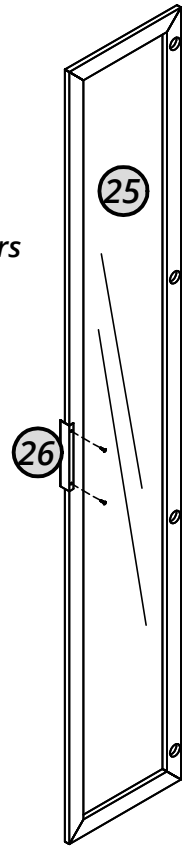
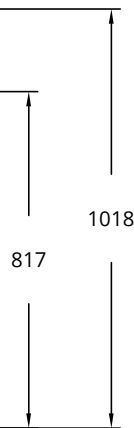

24

