

JK Gelius

INNOVA 1P NICH0

roupeiro | ropero | wardrobe

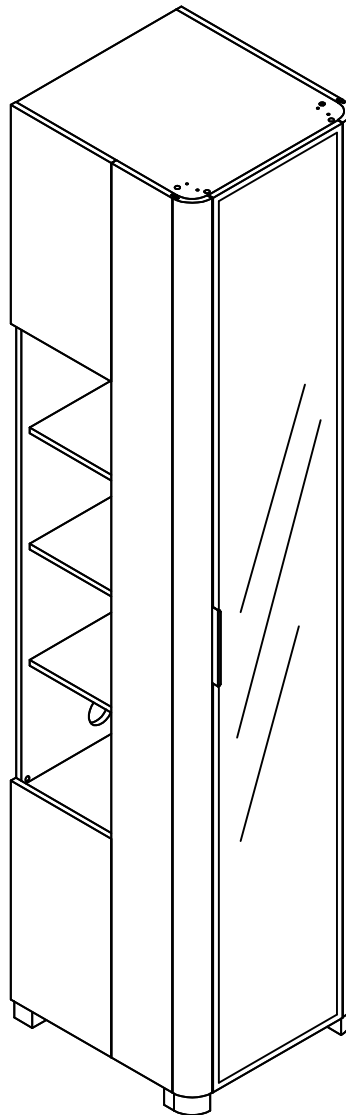

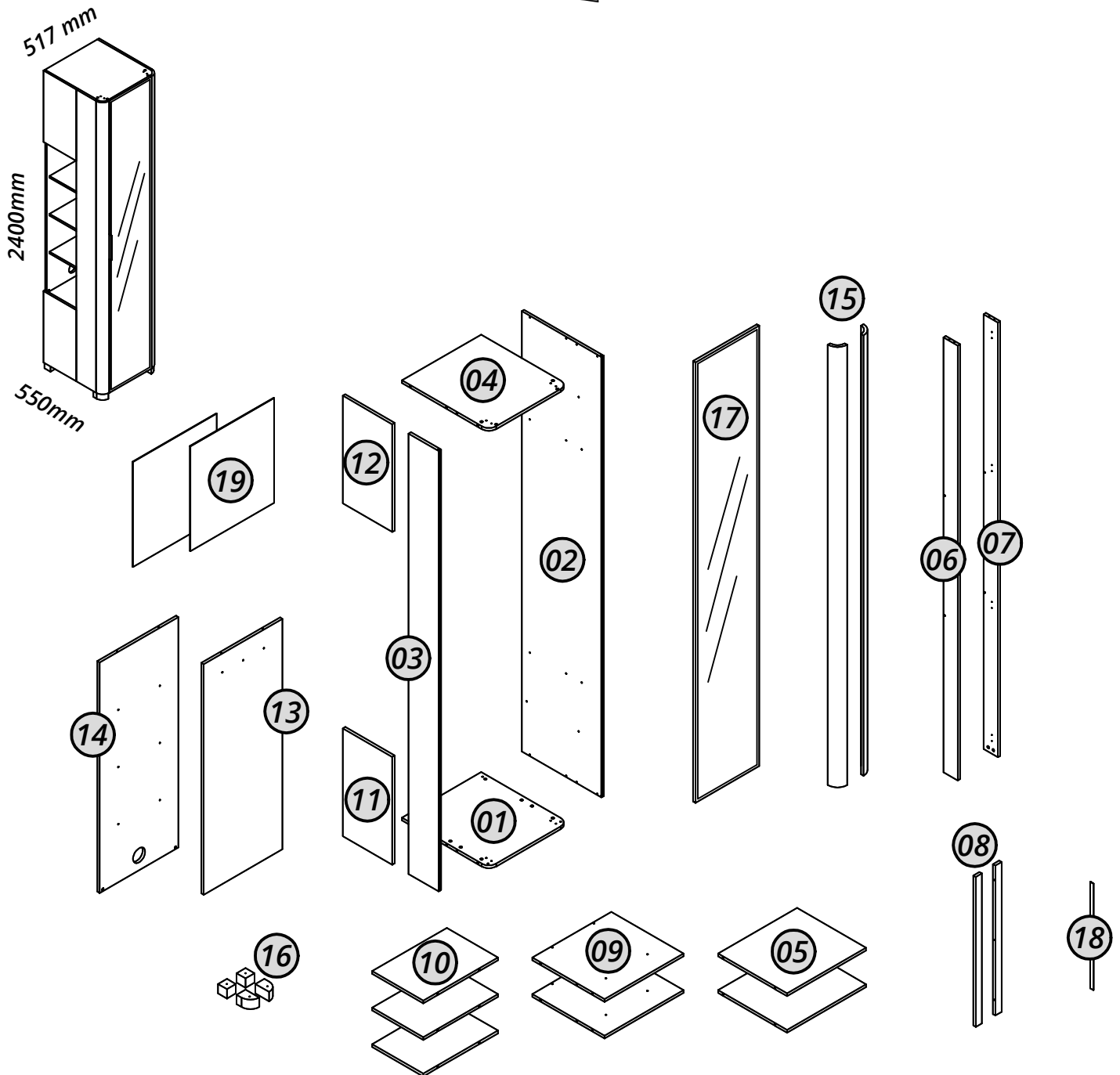

Nº	Cód.	Peças	Piezas	Parts	Medida	Qtd.	Vol.
01	09181	Base	Base	Base	535x487x15	01	2/2
02	09183	Lateral	Lateral	Side	2350x490x15	01	1/2
03	09184	Régua lateral	Regla lateral	Side ruler	2350x185x15	01	1/2
04	09182	Tampo	Cubierta	Top	535x487x15	01	2/2
05	09066	Prateleira	Estante	Shelf	487x425x15	05	2/2
06	09067	Régua dobradiça esquerda	Regla de bisagra izquierda	Left hinge ruler	2320x88x15	01	1/2
07	09068	Régua dobradiça direita	Regla de bisagra derecha	Right hinge ruler	2320x88x15	01	1/2
08	09069	Apoio régua dobradiça	Soporte de regla de bisagra	Hinge ruler support	80x38x15	02	2/2
09	09189	Prateleira maior	Estante más grande	Bigger shelf	487x445x15	02	2/2
10	09190	Prateleira do nicho	Estante de nicho	Niche shelf	460x315x15	03	2/2
11	09186	Painel lateral inferior	Panel lateral inferior	Lower side panel	575x305x15	01	2/2
12	09185	Painel lateral superior	Panel lateral superior	Top side panel	575x305x15	01	2/2
13	09188	Painel frontal	Panel frontal	Front panel	1230x486x15	01	2/2
14	09187	Painel traseiro	Panel trasero	Back panel	1230x486x15	01	2/2
15	*	Curva	Curva	Curve	2350x60x15	02	1/2
16	*	Kit pé	Kit pie	Kit foot	*	01	2/2
17	09103	Porta reflecta	Puerto reflectante	Reflective port	2350x392x18	01	1/1
18	08527	Trava da curva	Traba de curva	Curve lock	586x20x2,5	08	1/2
19	09191	Fundo traseiro	Fondo trasero	Back bottom	560x516x2,5	02	2/2

ATENÇÃO: Este manual é utilizado para diferentes versões deste produto. Por isso, algumas etapas de montagem, peças ou acessórios descritos podem não se aplicar à versão adquirida. Caso você identifique itens que não correspondam ao seu modelo (como espelho, pés, LED, entre outros), desconsidere essas instruções e componentes. A presença desses itens no manual ou na embalagem não configura erro ou falta de peças.

Recorte aqui e guarde seu certificado de garantia!

Certificado de garantia

A Gelius Indústria de Móveis confia na qualidade de seus produtos e por isso o garante pelo prazo de 90 dias para defeitos de fabricação em condições normais de uso.

Resultarão nula a garantia e sem efeito a cobertura, se o produto, (incluindo vidros e ou espelhos que o compõe):

- sofrer dano provocado por acidente, agente da natureza.
- uso indevido ou maus tratos como arrastar, subir em cima, colocar produtos com excesso de peso.
- não utilizado para os fins a que se destina.
- conter manchas provocadas por uso de produtos químicos em sua limpeza.
- excesso de umidade ou água.

Ao detectar qualquer defeito em seu móvel, entre em contato com a loja onde foi efetuada a compra. A comprovação de que o móvel a ser consertado ou substituído encontra-se dentro do prazo de garantia é de total responsabilidade do fabricante e deve ser feita mediante a apresentação desse certificado corretamente preenchido e sem rasuras ou resalvas.

Cuidados com seu móvel Gelius!

- para limpeza do seu móvel, utilize apenas pano macio e seco.
- jamais limpe-o com palha de aço, álcool ou qualquer outro produto químico ou abrasivos, óleos de peroba ou produtos do gênero.
- evite deixá-lo sob raios solares ou chuva.
- ao transportar o seu móvel Gelius, prenda-o firmemente para que não ocorra quedas indesejáveis.

Seguindo corretamente as informações acima, você conservará por muito mais tempo o seu móvel Gelius!

GARANTIA DO CLIENTE:

Cliente: _____

Rua: _____ Nº: _____ Bairro: _____

Cidade: _____ UF: _____ Loja onde comprou: _____

Data da compra: ____/____/____ Nota Fiscal: _____

Data da reclamação na loja: ____/____/____

Defeito constante: _____

Recomendações | Recomendaciones | Recommendations

Atenção
Atención
Attention

Este produto deve ser montado por um profissional.

Este producto debe ser ensamblado por un profesional.

This product must be assembled by a professional.

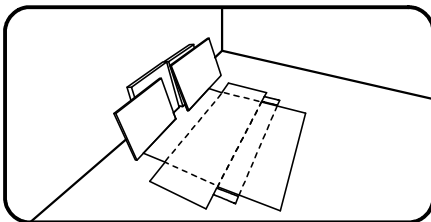

Antes de começar a montagem prepare o ambiente, deixando-o completamente limpo e com bom espaço para iniciar o trabalho. Utilize o papelão da própria embalagem para separar e apoiar as peças retiradas da caixa.

Antes de comenzar el montaje preparar el ambiente, dejándolo completamente limpio y con buen espacio para comenzar el trabajo. Utilice el cartón de la embalaje para separar y apoyar las piezas desmontadas de las cajas.

Prepare the room before starting the assembly, leaving it completely clean and the area in good condition to start the work. Use the cardboard of the packaging to separate and support the parts removed from the boxes.

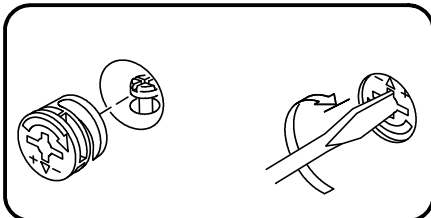

Como usar o acessório Pino e Tambor Minifix (quando utilizado no produto).

Como usar el herraje Pino y Tambor Minifix (cuando se usa en el producto).

How to use the Minifix Set (when used in the product).

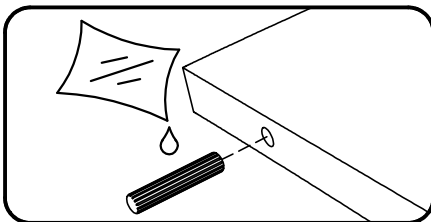

Aplicar cola nas cavilhas de madeira (quando utilizado no produto).

Aplicar pegamento a las clavijas de madera (cuando se usa en el producto).

Apply glues to the wooden dowels (when used in the product).

Ferramentas recomendadas para montagem | Herramientas de montaje recomendadas | Recommended tools

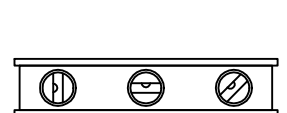
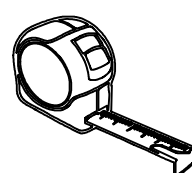
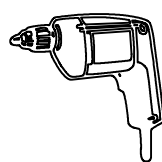
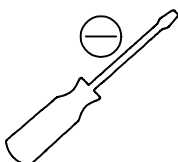
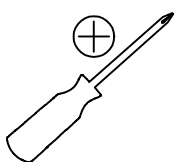

Acessórios e ferragens | Herrajes | Hardware

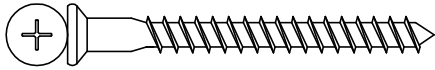

A — cód. 30010093 022 un.



B — cód. 30014538 047 un.



C — cód. 30014537 024 un.

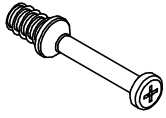

D — cód. 30006753 032 un.

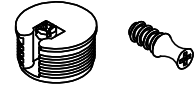

E — cód. 30001073 032 un.

 F — cód. 30021057 020 un.
 cód. 30021058 020 un.



G — cód. 30000782 040 un.

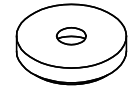

H — cód. 30014656 014 un.

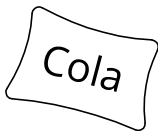

I — cód. 30000853 004 un.



J — cód. 30000709 004 un.



K — cód. 30021588 003 un.



L — cód. * 050 un.



M — cód. 30007801 010 un.

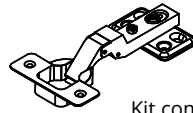

N — cód. 30021355 001 un. Kit com 4 peças



O — cód. * 001 un.

*Parafuso utilizado para unir módulos, quando for o caso.

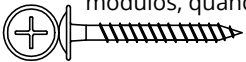

P — cód. 30000843 006 un.

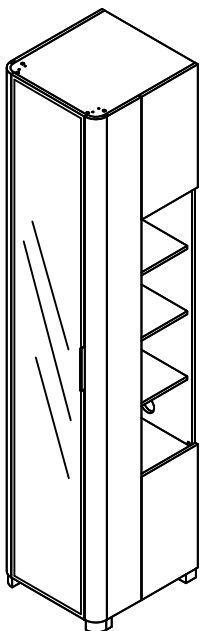
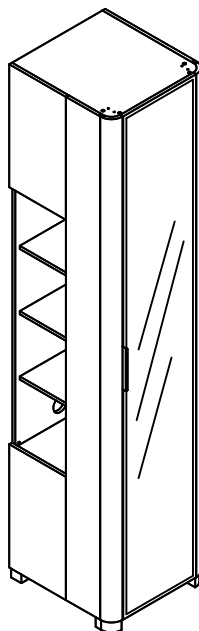
Lado esquerdo
Lado izquierdo
Left side

Lado direito
Lado derecho
Right side

Este produto pode ser montado de duas formas, conforme mostra a imagem ao lado.

Este producto puede montarse de dos formas, como muestra la imagen al lado.

This product can be assembled in two ways, as shown in the image beside.

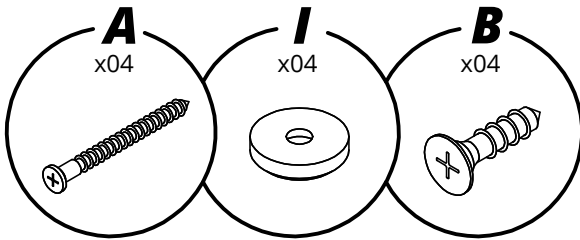
01



Para garantir a segurança durante a montagem, recomendamos que o produto seja montado por duas pessoas. Alternativamente, você pode optar por montá-lo deitado e, em seguida, levantá-lo após a montagem estar concluída.

Para garantizar la seguridad durante el montaje, recomendamos que el producto sea ensamblado por dos personas. Alternativamente, puede optar por ensamblarlo mientras está acostado y luego levantarlo una vez completado el montaje.

To ensure safety during assembly, we recommend that the product be assembled by two people. Alternatively, you may choose to assemble it while it is lying down and then lift it up once assembly is complete.

16

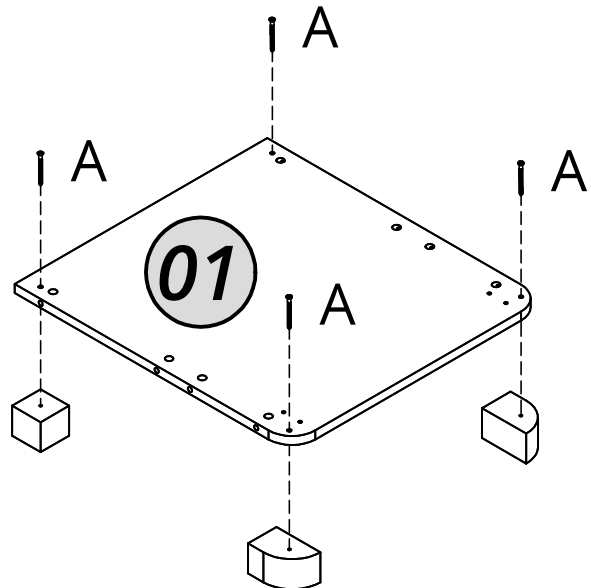
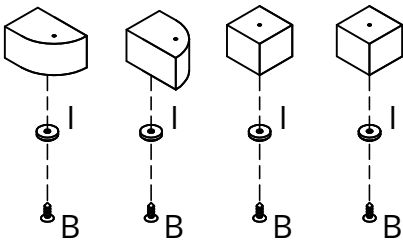

02

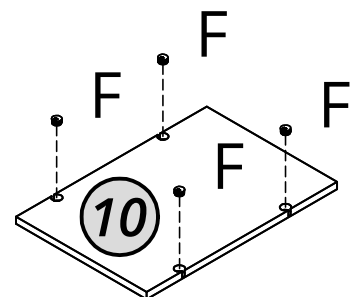
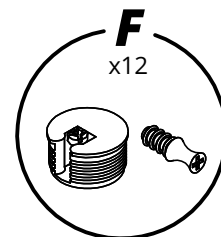
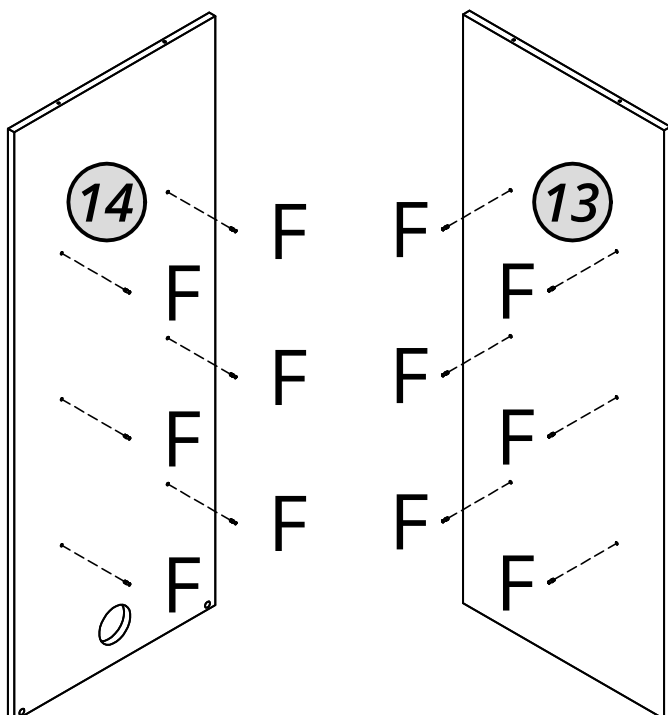

03

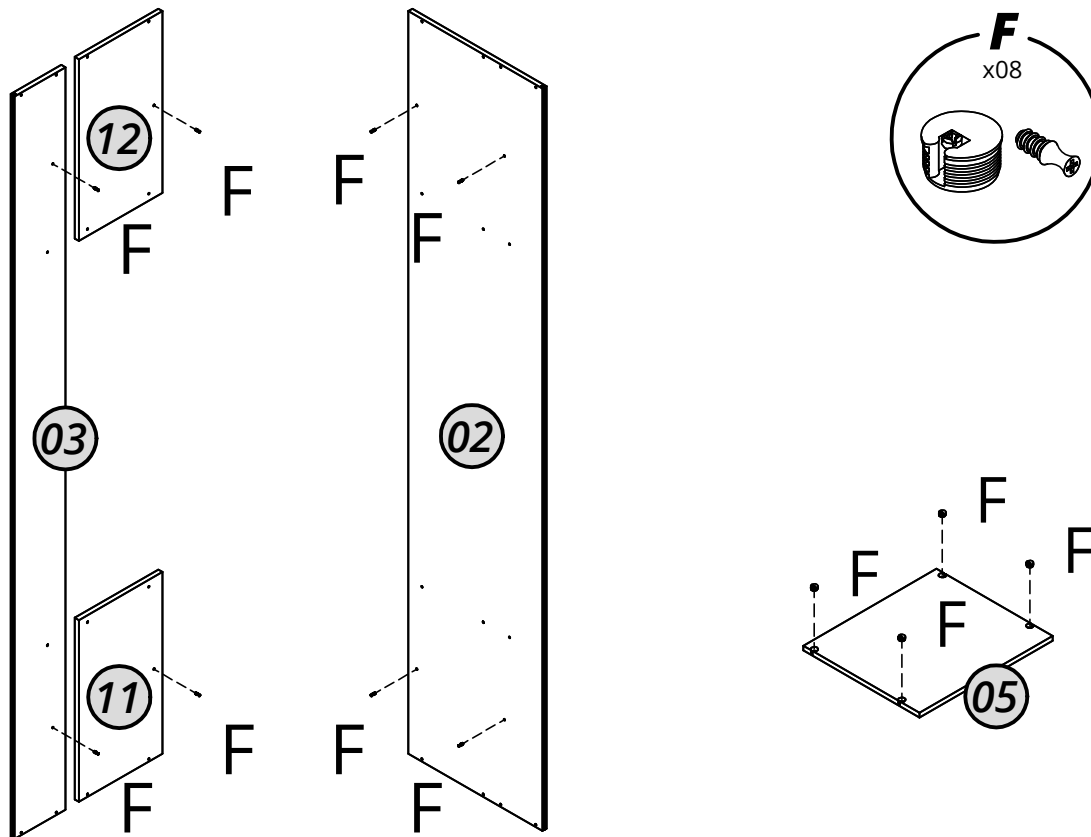

04

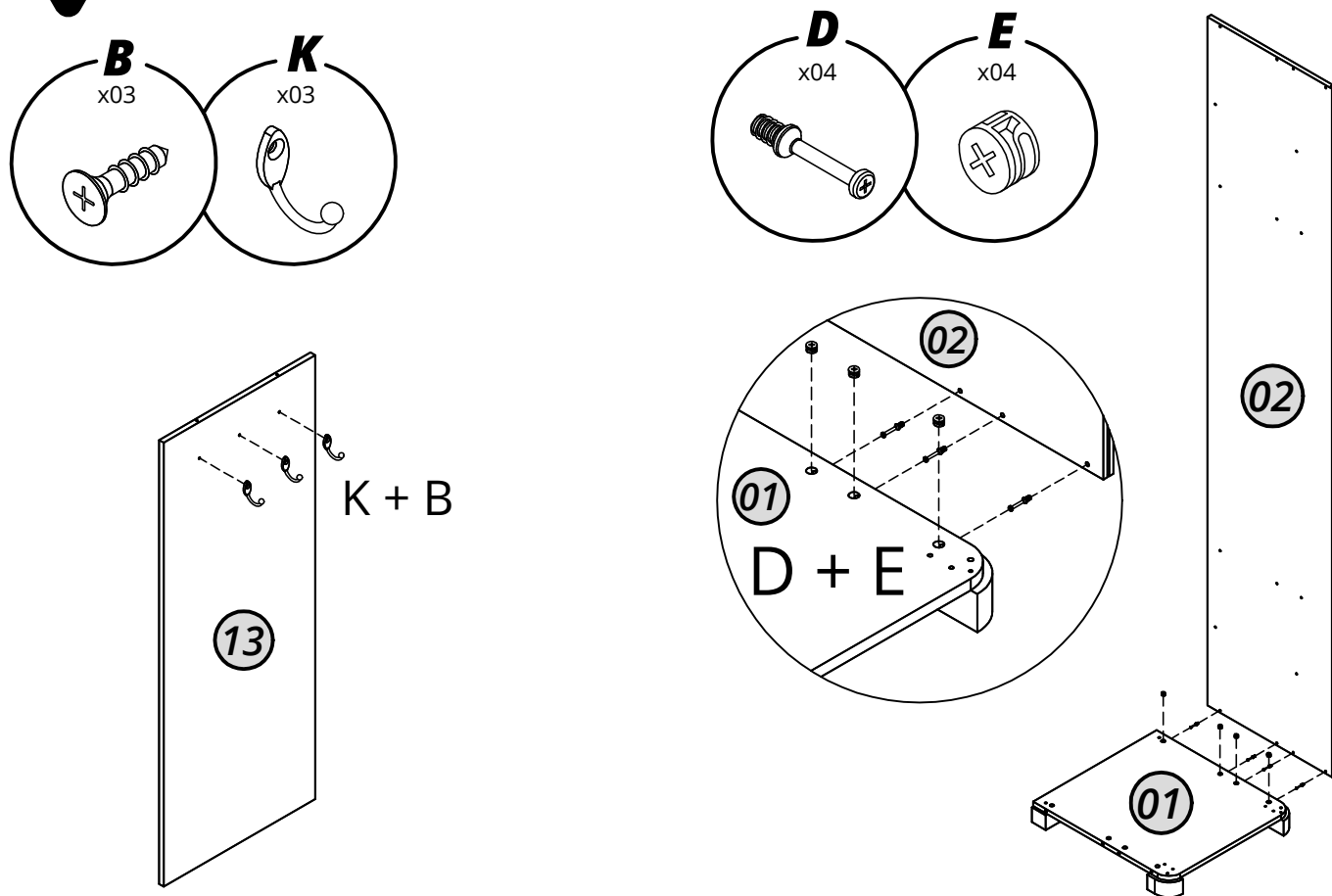

05

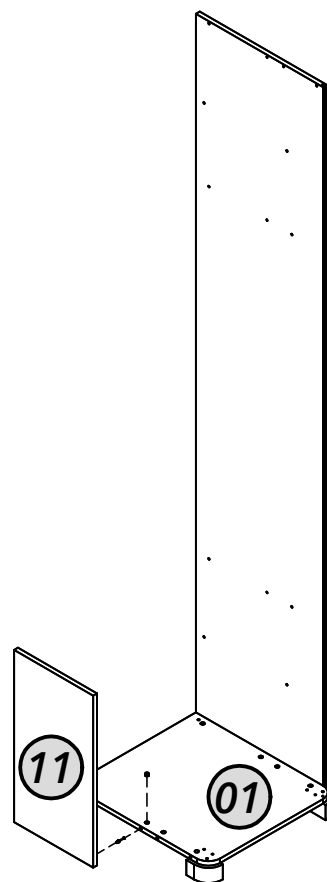
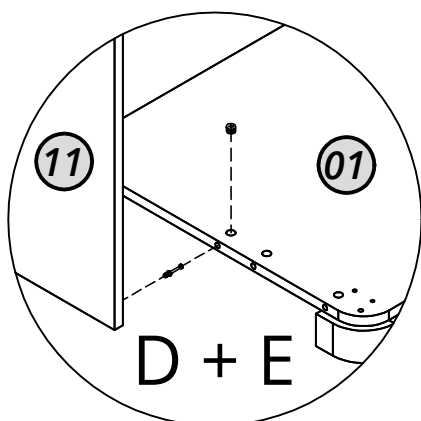
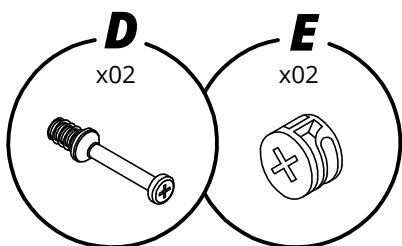

06

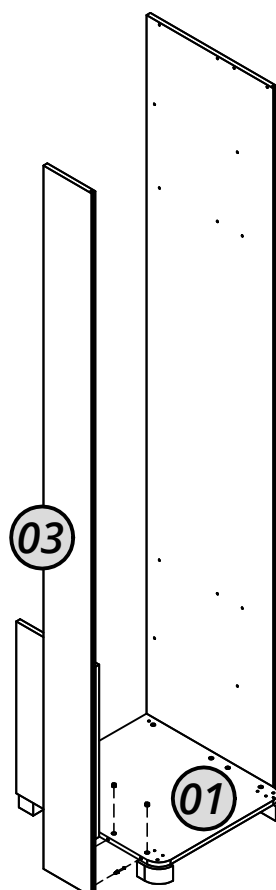
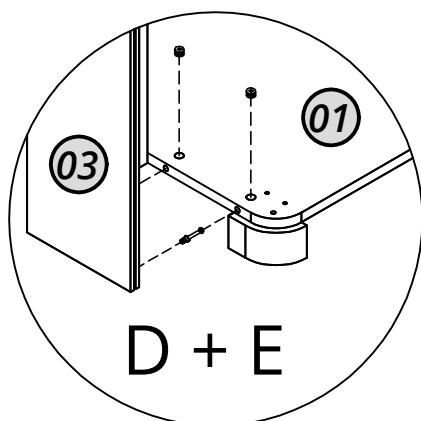
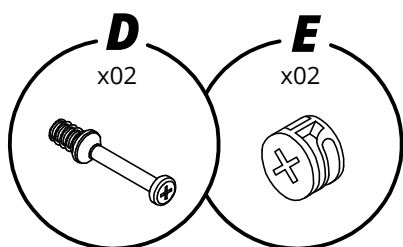

07

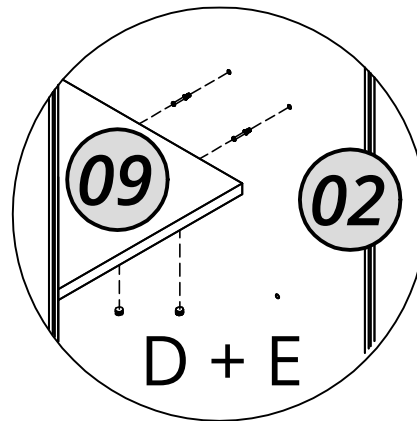
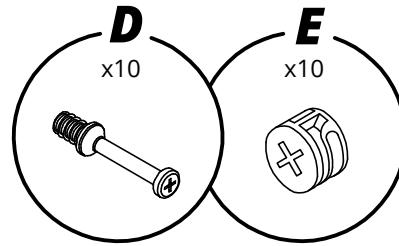
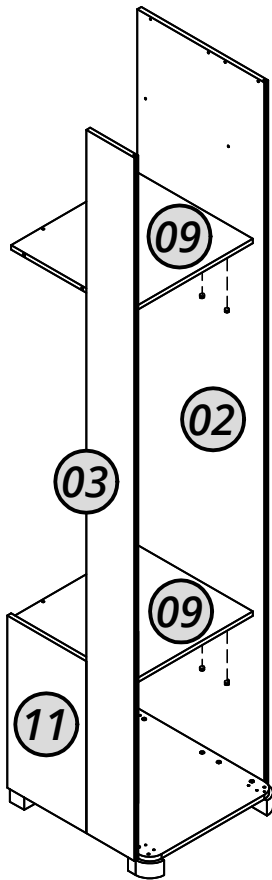

08

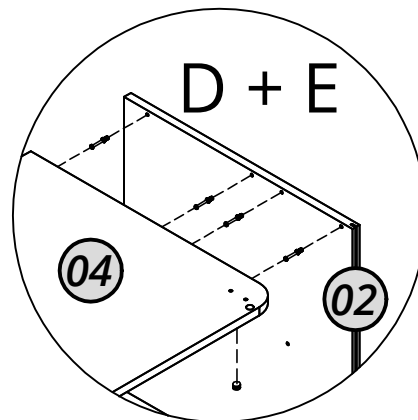
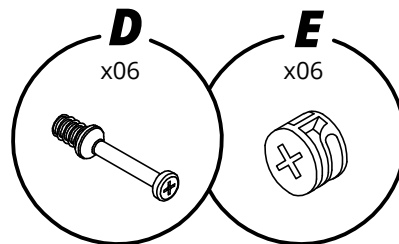
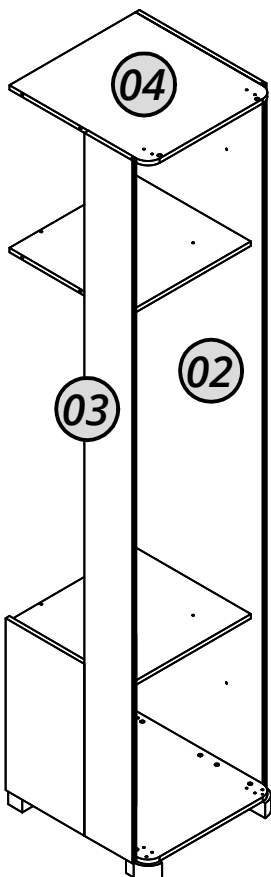

09

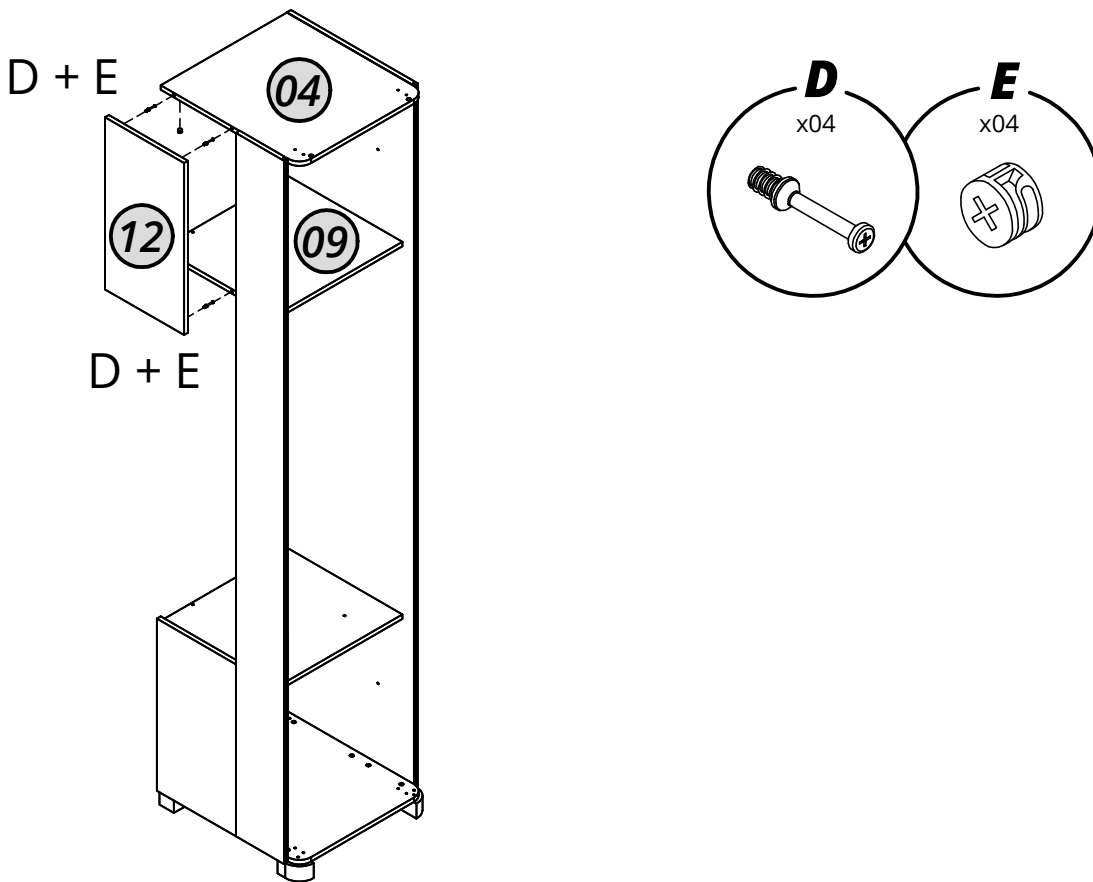

10

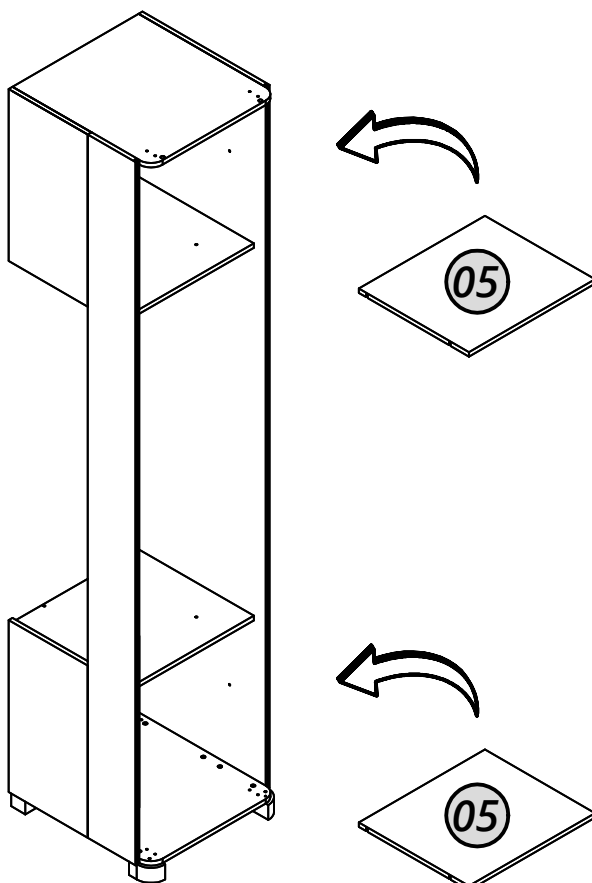

Encaixe as prateleiras (05) no local indicado na imagem ao lado.

Encaje los estantes (05) en el lugar indicado en la imagen al lado.

Fit the shelves (05) into the location shown in the image beside.

11

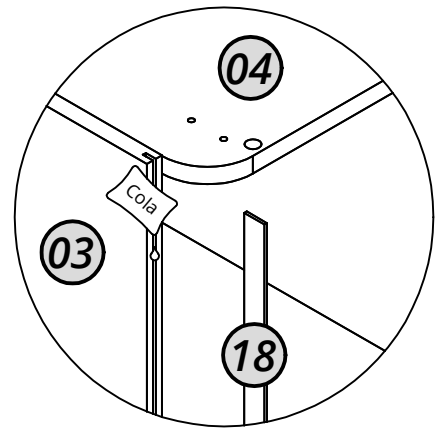
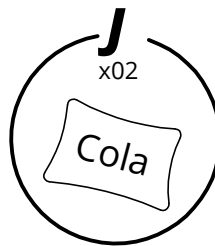
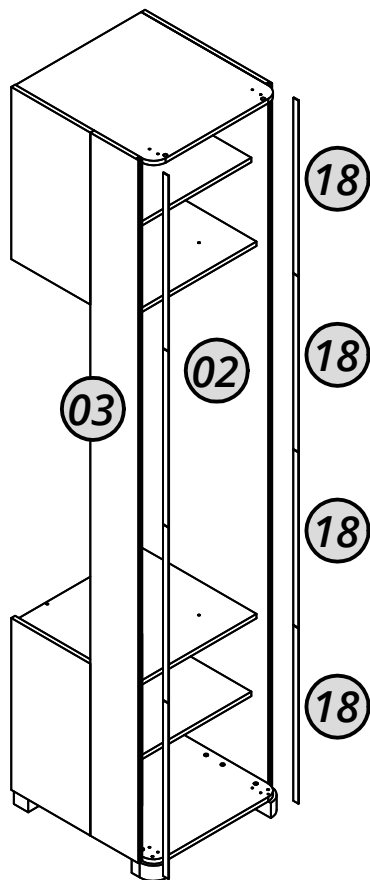

Aplicar cola nos canais da lateral (02) e da régua lateral (03), e encaixar as travas da curva (18).

Aplicar pegamento en los canales del lateral (02) y de la regla lateral (03), y encajar las trabas de la curva (18).

Apply glue to the channels of the side panel (02) and the side rail (03), and fit the curve locks (18).

12

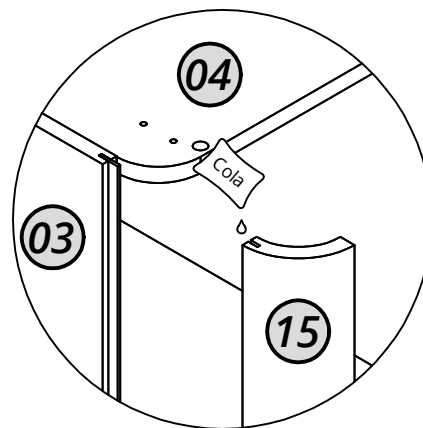
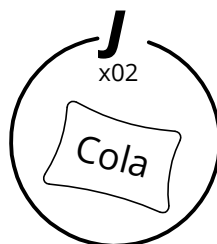
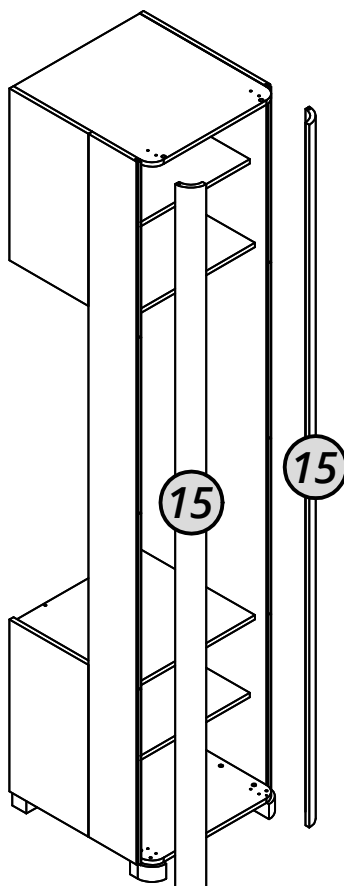

Aplicar cola no canal da curva (15) e encaixar nas travas da curva (18).

Aplicar pegamento en el canal de la curva (15) y encajar en las trabas de la curva (18).

Apply glue to the channel of the curve (15) and fit into the curve locks (18).

13

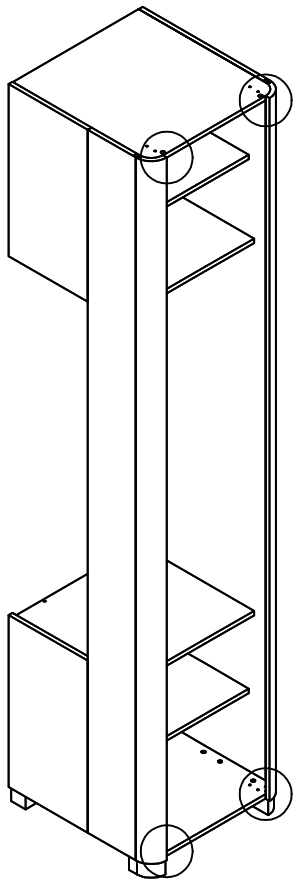

Prenda a curva na parte de baixo (Base) e na parte de cima (Tampo) usando a cantoneira.

Sujeta la curva a la base y a la parte superior usando la escuadra.

Attach the curve to the base and the top using the bracket.

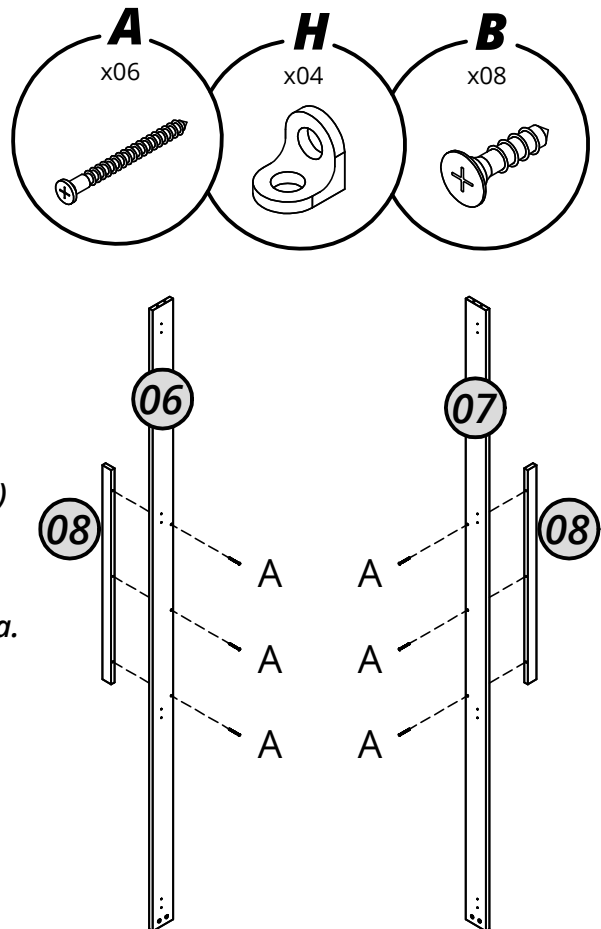

14

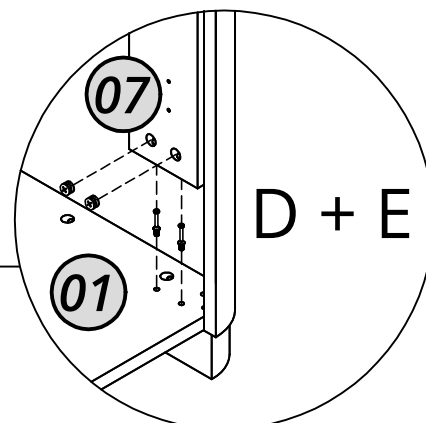
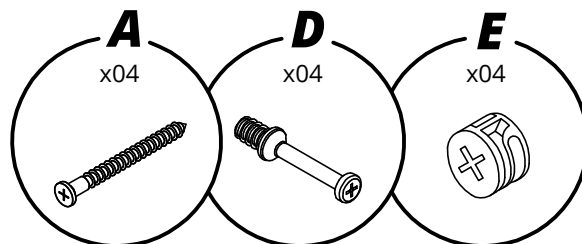
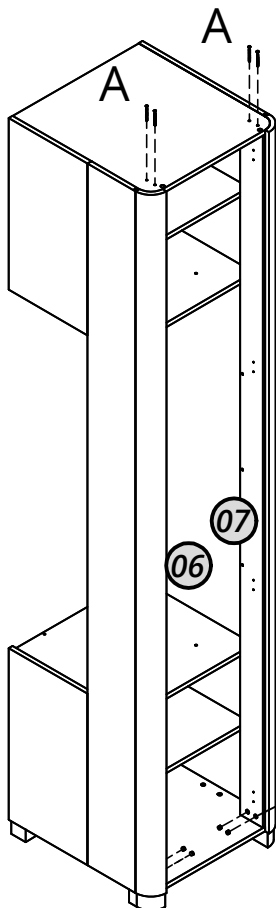

15

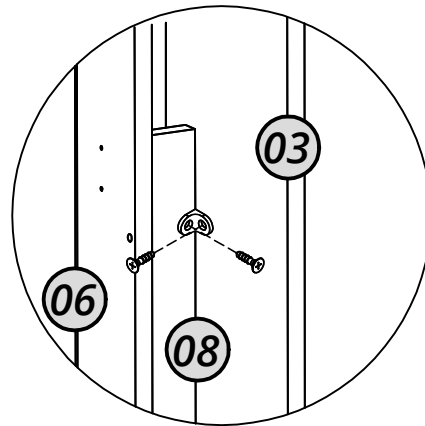
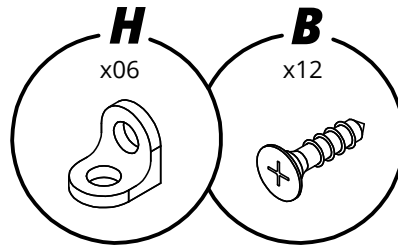
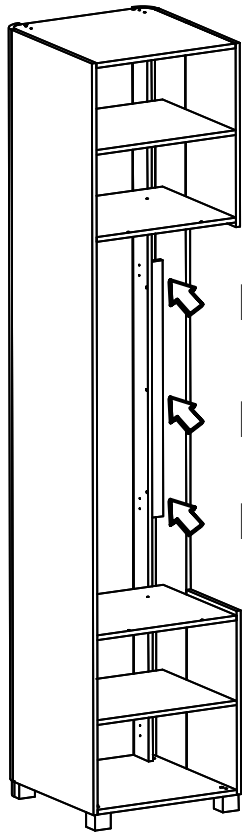

16

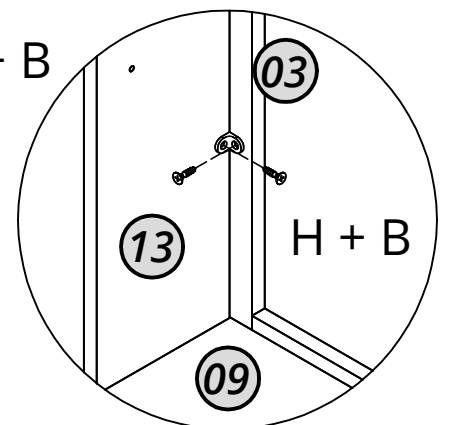
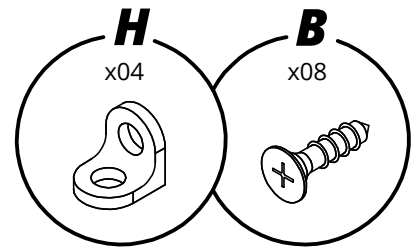
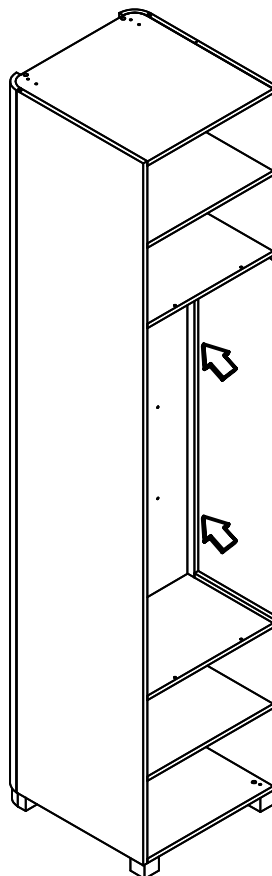
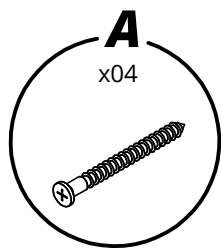
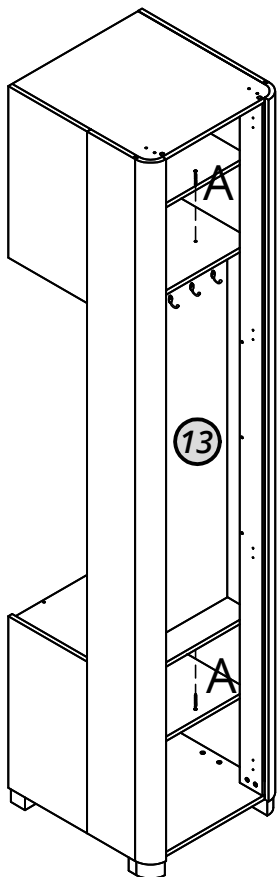

17

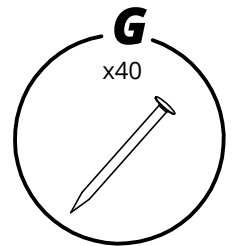
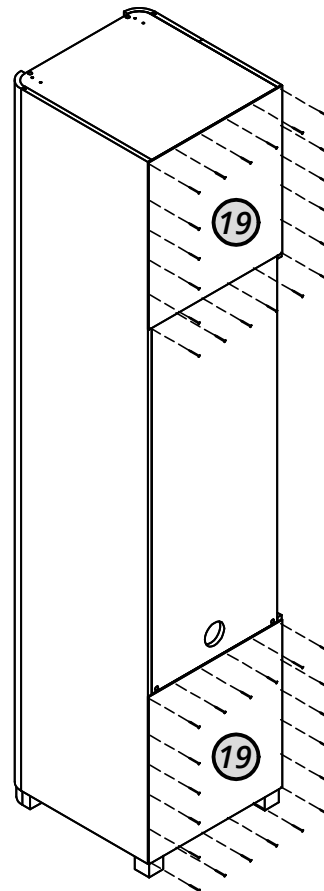
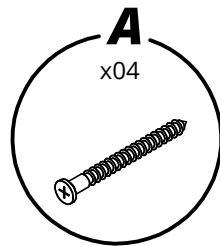
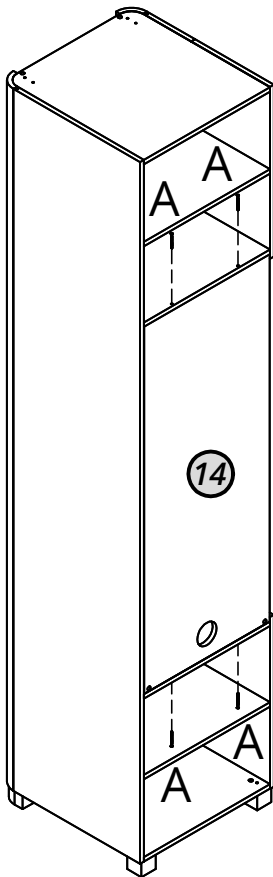

18

Encaixe as prateleiras do nicho (10) no local indicado na imagem ao lado.

Encaje las repisas del nicho (10) en el lugar indicado en la imagen al lado.

Fit the shelves of the niche (10) into the location indicated in the image beside.

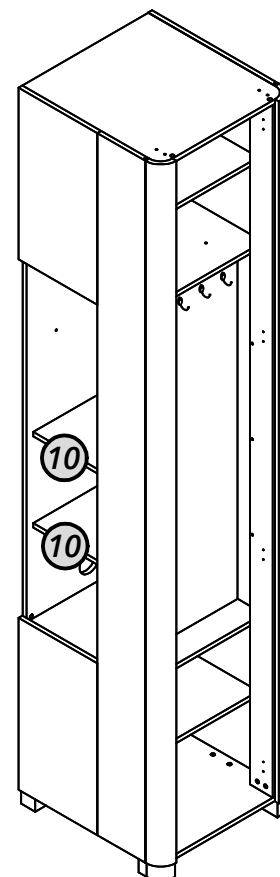
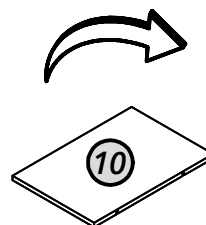

INSTALAÇÃO DO KIT LED

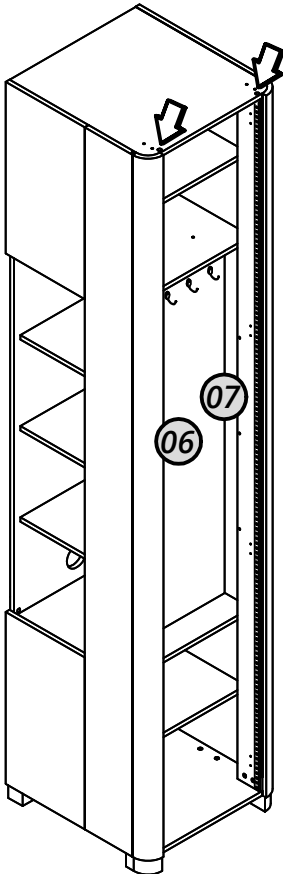

Passes as duas fitas de LED MAIORES pelas furações do tampo (04), indicadas pelas setas, e cole-a nas réguas das dobradiças (06 e 07).

Pase las dos cintas LED MÁS LARGAS por las perforaciones del tablero (04), indicadas por las flechas, y péguelas en las guías de las bisagras (06 y 07).

Pass the two LONGER LED strips through the holes in panel (04), as indicated by the arrows, and stick them onto the hinge rails (06 and 07).

Passes a fita de LED MENOR pela furação do painel traseiro (14), indicada pela seta, e cole-a na parte interna do nicho, seguindo o desenho ao lado.

Pase la cinta LED MENOR por la perforación del panel trasero (14), indicada por la flecha, y péguela en la parte interna del nicho, siguiendo el dibujo al lado.

Pass the SMALLER LED strip through the hole in the back panel (14), as indicated by the arrow, and stick it to the inside of the niche, following the diagram beside.

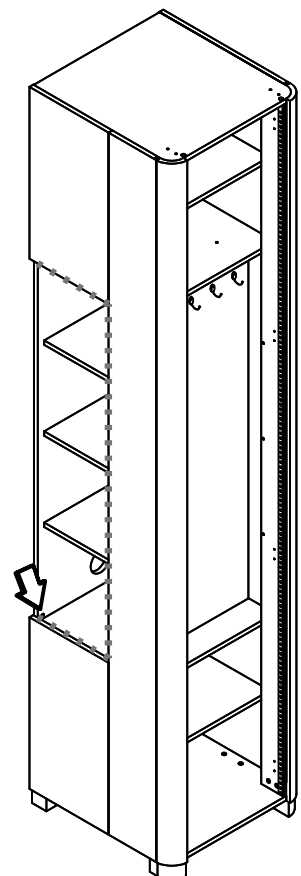

INSTALAÇÃO DO KIT LED

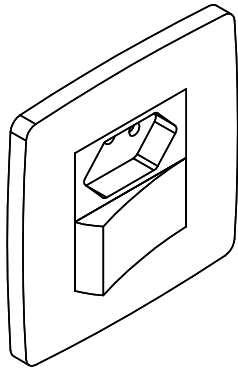

Encaixe a tomada no local indicado pela seta e utilize os acessórios M e B para organizar as fiações.

Encaje el tomacorriente en el lugar indicado por la flecha y utilice los accesorios M y B para organizar los cables.

Insert the outlet into the location indicated by the arrow and use accessories M and B to organize the wiring.

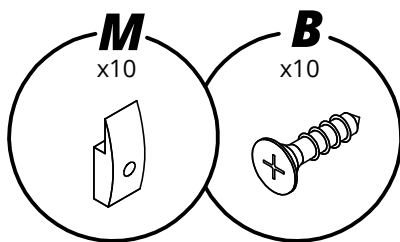
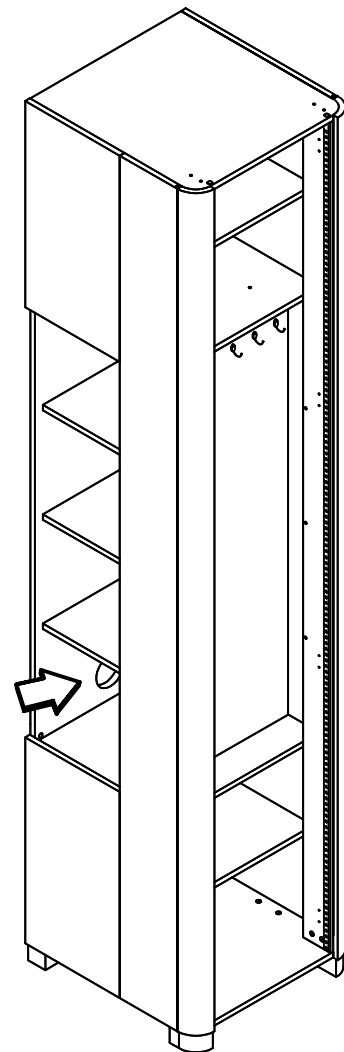

21

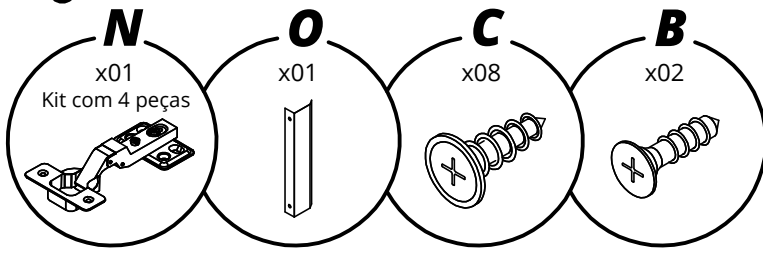

Centralize o puxador na porta.

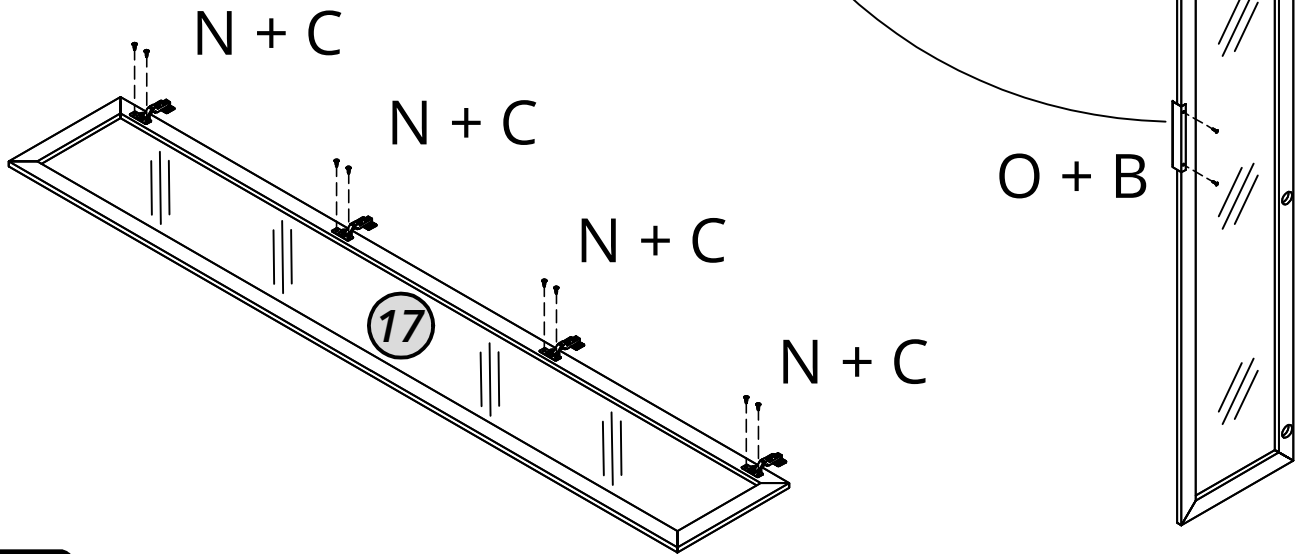

22

