

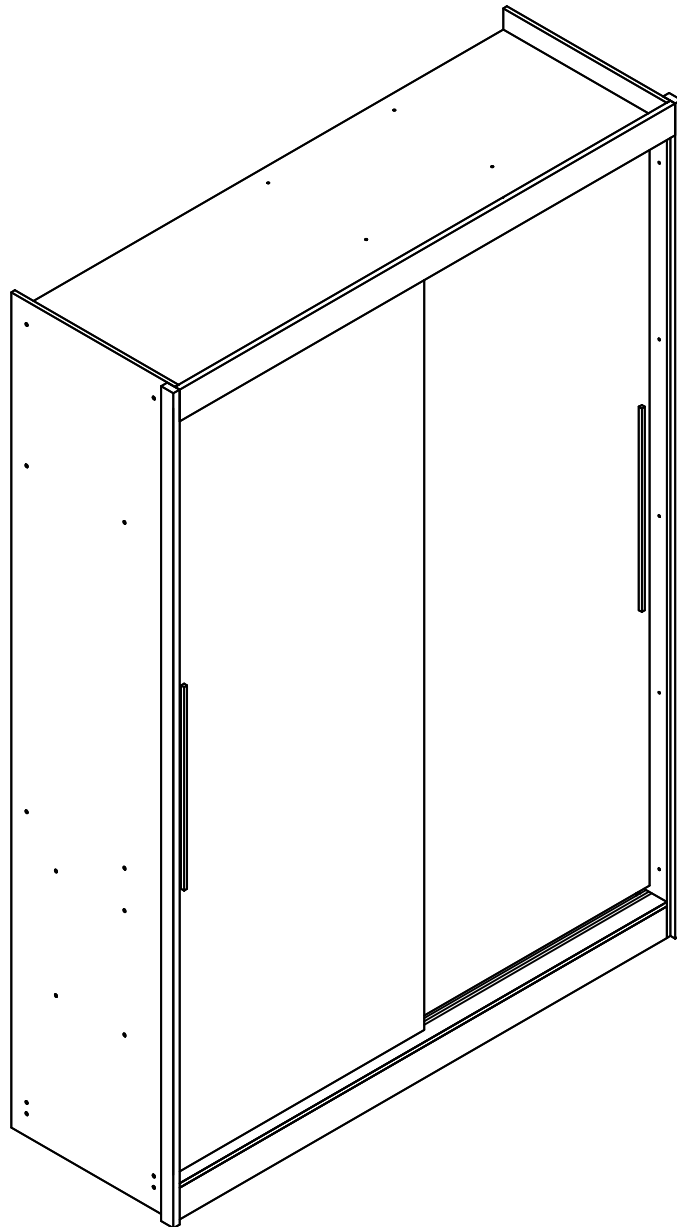

roupeiro | ropero | wardrobe

AGATA 2P

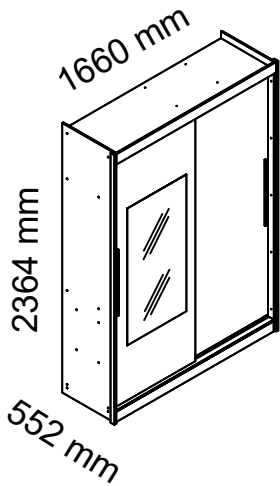
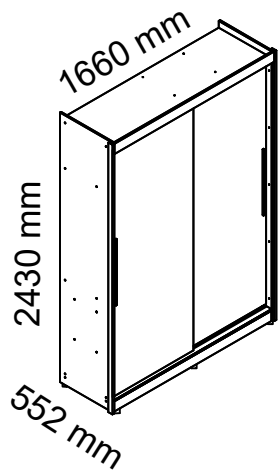
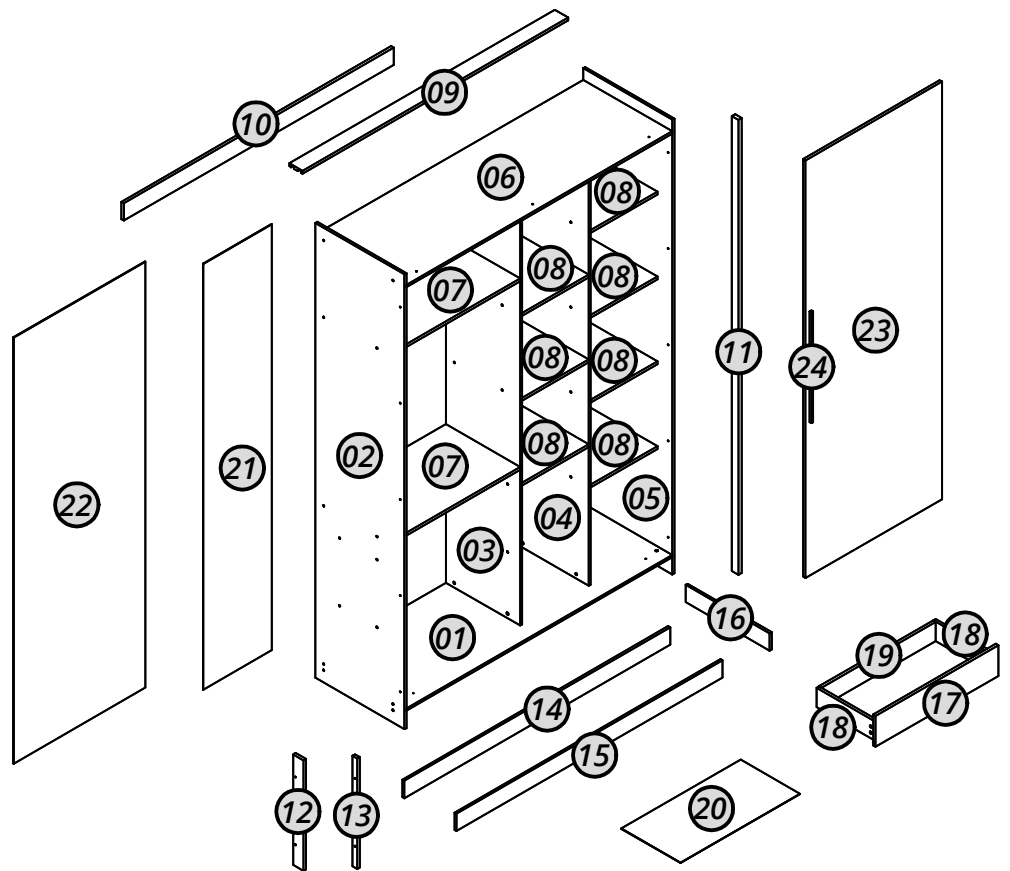

Versão com espelho

Versão com kit pé

Atenção: Espelho e kit pé é vendido separadamente.

Nº	CÓD.	PEÇAS	PIEZAS	PARTS	MEDIDA/SIZE	QTD.	VOL.
01	08539	Base	Base	Base	1596x535x12	01	3/3
02	08541	Lateral esquerda	Lateral izquierda	Left side	2364x535x12	01	1/3
03	08543	Divisória esquerda	División izquierda	Left division	2190x445x12	01	2/3
04	08544	Divisória direita	División derecha	Right division	2190x445x12	01	2/3
05	08542	Lateral direita	Lateral derecha	Right side	2364x535x12	01	1/3
06	08539	Tampo	Cubierta	Top panel	1596x535x12	01	3/3
07	08548	Prateleira maior	Estante más grande	Bigger shelf	772x445x15	02	3/3
08	08549	Prateleira menor	Estante más pequeña	Smaller shelf	400x445x15	07	2/3
09	08553	Trilho superior	Riel superior	Top rail	1594x80x15	01	1/3
10	08554	Moldura frontal	Marco frontal	Front frame	1620x90x15	01	1/3
11	08558	Moldura lateral	Marco lateral	Side frame	2364x80x20	02	1/3
12	08556	Distanciador maior	Espaciador más grande	Larger spacer	574x63x15	02	3/3
13	08557	Distanciador menor	Espaciador más pequeño	Smaller spacer	574x28x15	02	3/3
14	08546	Rodapé traseiro	Rodapíe trasero	Lower rear crossbar	1596x90x12	01	1/3
15	08545	Rodapé frontal	Rodapíe frontal	Lower front crossbar	1596x90x12	01	1/3
16	08547	Trava rodapé	Traba del rodapíe	Smaller crossbar	505x90x12	03	3/3
17	08550	Frente de gaveta	Frente del cajón	Front of drawer	736x160x15	03	3/3
18	08551	Lateral de gaveta	Lateral del cajón	Side of drawer	350x100x15	06	3/3
19	08552	Contra fundo de gaveta	Trasero del cajón	Rear of drawer	686x100x15	03	3/3
20	08559	Fundo de gaveta	Fondo del cajón	Drawer bottom	716x355x2,5	03	1/3
21	08562	Fundo menor	Fondo más pequeño	Smaller background	2214x412x2,5	02	1/1
22	08561	Fundo maior	Fondo más grande	Bigger background	2214x790x2,5	01	1/1
23	08560	Porta	Puertas	Doors	2170x820x15	02	1/1
24	30009116	Puxador	Tirador	Handle	576x10x10	02	1/1

Recorte aqui e guarde seu certificado de garantia!

Certificado de garantia

A Gelius Indústria de Móveis confia na qualidade de seus produtos e por isso o garante pelo prazo de 90 dias para defeitos de fabricação em condições normais de uso.

Resultarão nula a garantia e sem efeito a cobertura, se o produto, (incluindo vidros e ou espelhos que o compõe):

- sofrer dano provocado por acidente, agente da natureza.
- uso indevido ou maus tratos como arrastar, subir em cima, colocar produtos com excesso de peso).
- não utilizado para os fins a que se destina.
- conter manchas provocadas por uso de produtos químicos em sua limpeza.
- excesso de umidade ou água.

Ao detectar qualquer defeito em seu móvel, entre em contato com a loja onde foi efetuada a compra. A comprovação de que o móvel a ser consertado ou substituído encontra-se dentro do prazo de garantia é de total responsabilidade do fabricante e deve ser feita mediante a apresentação desse certificado corretamente preenchido e sem rasuras ou resalvas.

Cuidados com seu móvel Gelius!

- para limpeza do seu móvel, utilize apenas pano macio e seco.
- jamais limpe-o com palha de aço, álcool ou qualquer outro produto químico ou abrasivos, óleos de peroba ou produtos do gênero.
- evite deixá-lo sob raios solares ou chuva.
- ao transportar o seu móvel Gelius, prenda-o firmemente para que não ocorra quedas indesejáveis.

Seguindo corretamente as informações acima, você conservará por muito mais tempo o seu móvel Gelius!

GARANTIA DO CLIENTE:

Cliente: _____

Rua: _____ Nº: _____ Bairro: _____

Cidade: _____ UF: _____ Loja onde comprou: _____

Data da compra: ____/____/____ Nota Fiscal: _____

Data da reclamação na loja: ____/____/____

Defeito constante: _____

Recomendações | Recomendaciones | Recommendations

Atenção
Atención
Attention

Este produto deve ser montado por um profissional.

Este producto debe ser ensamblado por un profesional.

This product must be assembled by a professional.

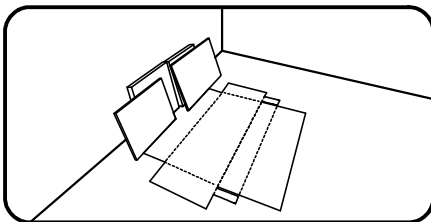

Antes de começar a montagem prepare o ambiente, deixando-o completamente limpo e com bom espaço para iniciar o trabalho. Utilize o papelão da própria embalagem para separar e apoiar as peças retiradas da caixa.

Antes de comenzar el montaje preparar el ambiente, dejándolo completamente limpio y con buen espacio para comenzar el trabajo. Utilice el cartón de la embalaje para separar y apoyar las piezas desmontadas de las cajas.

Prepare the room before starting the assembly, leaving it completely clean and the area in good condition to start the work. Use the cardboard of the packaging to separate and support the parts removed from the boxes.

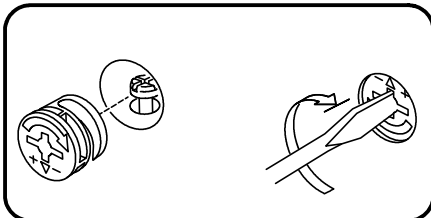

Como usar o acessório Pino e Tambor Minifix (quando utilizado no produto).

Como usar el herraje Pino y Tambor Minifix (cuando se usa en el producto).

How to use the Minifix Set (when used in the product).

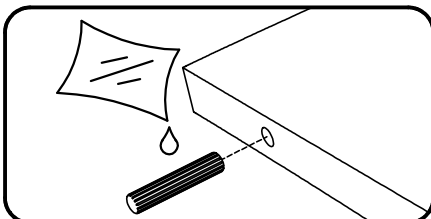

Aplicar cola nas cavilhas de madeira (quando utilizado no produto).

Aplicar pegamento a las clavijas de madera (cuando se usa en el producto).

Apply glues to the wooden dowels (when used in the product).

Ferramentas recomendadas para montagem | Herramientas de montaje recomendadas | Recommended tools

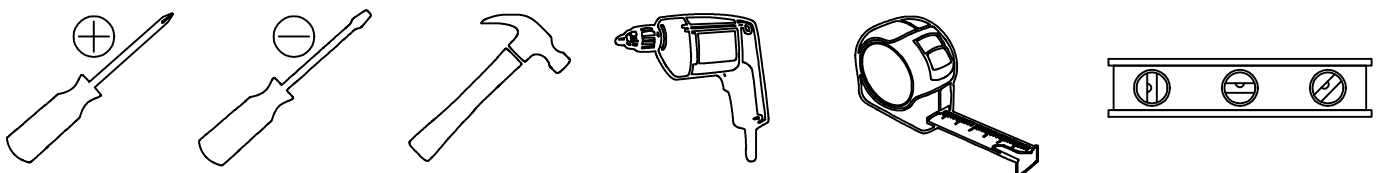

Acessórios e ferragens | Herrajes | Hardware

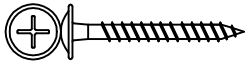

A - cód. 30000843 013 un.



B - cód. 30000711 173 un.

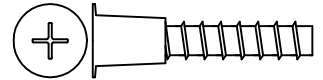

C - cód. 30000674 008 un.

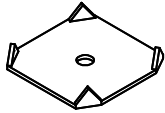

D - cód. 30001164 046 un.



E - cód. 30000783 160 un.

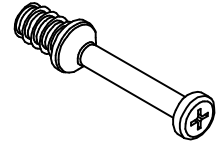

F - cód. 30006753 020 un.



G - cód. 30001073 020 un.

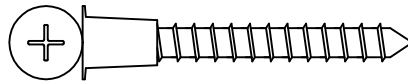

H - cód. 30008477 045 un.



I - cód. 30010241 004 un.

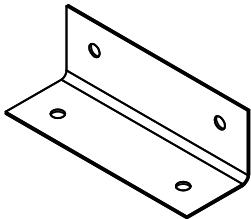

J - cód. 30003829 014 un.

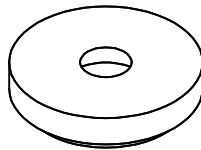

K - cód. 30000853 010 un.

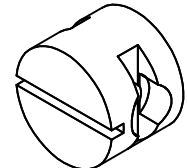

L - cód. 30008479 008 un.

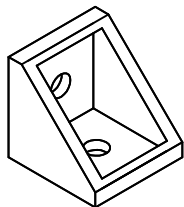

M - cód. 30009931 018 un.

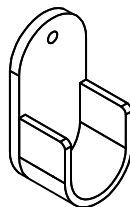

N - cód. 30001188 004 un.

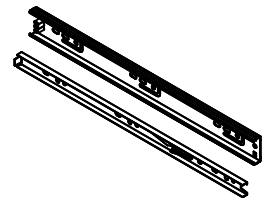

O - cód. 30013843 003 un.

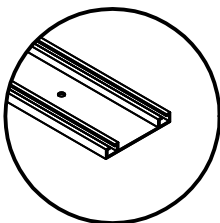

P - cód. 30020341 001 un.

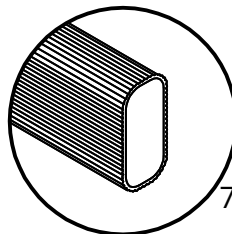

Q - cód. 30020338 001 un.

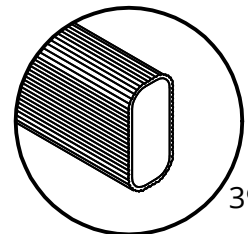

R - cód. 30003738 001 un.

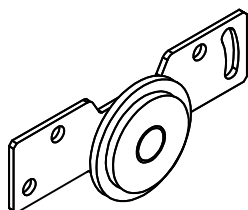

S - cód. 30015649 001 un.

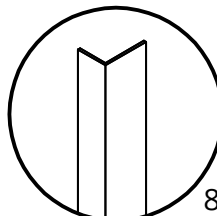

T - cód. 3001123 800mm 002 un.

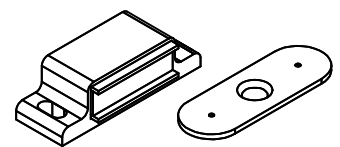

U - cód. 30011233 002 un.

01

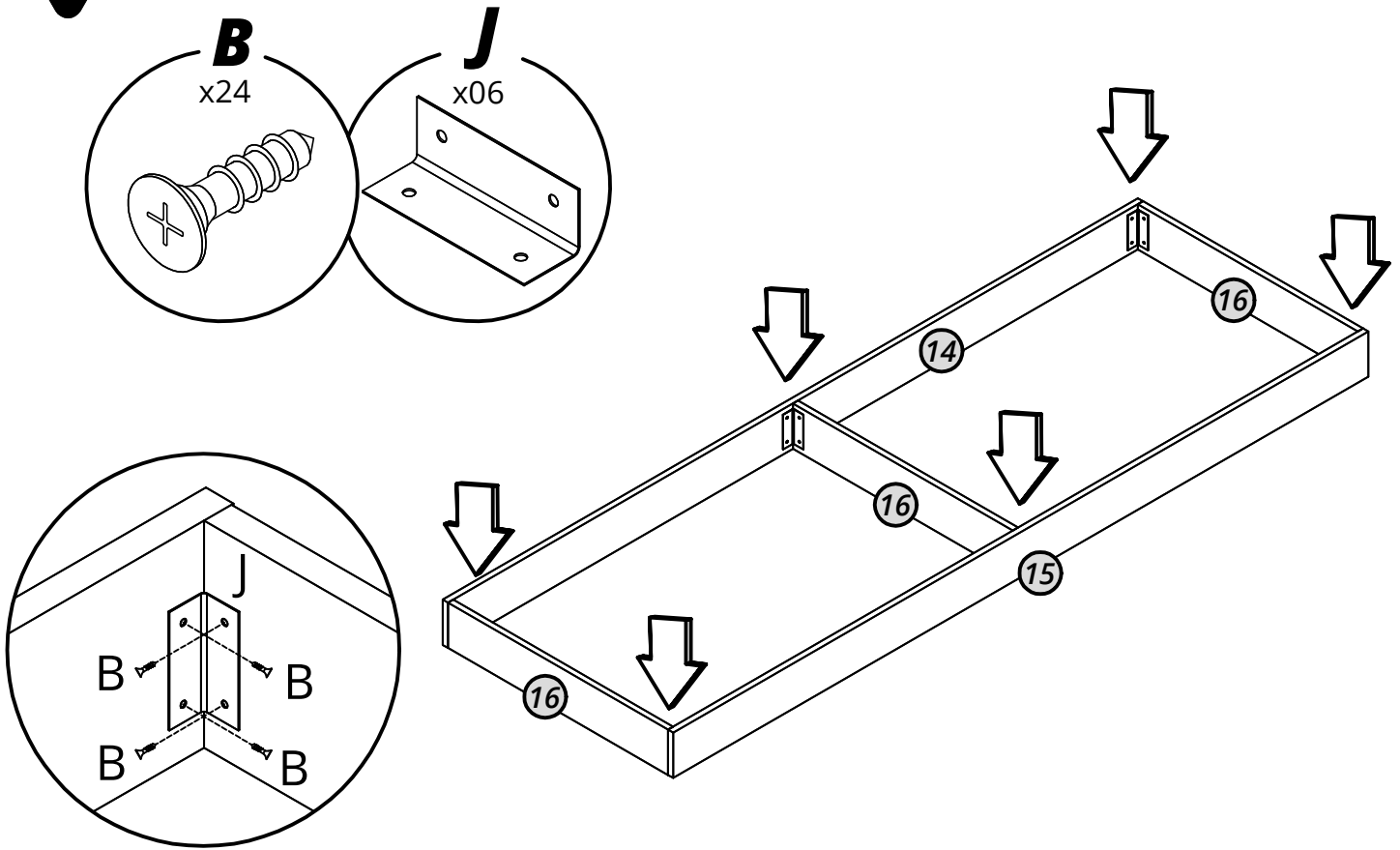

02

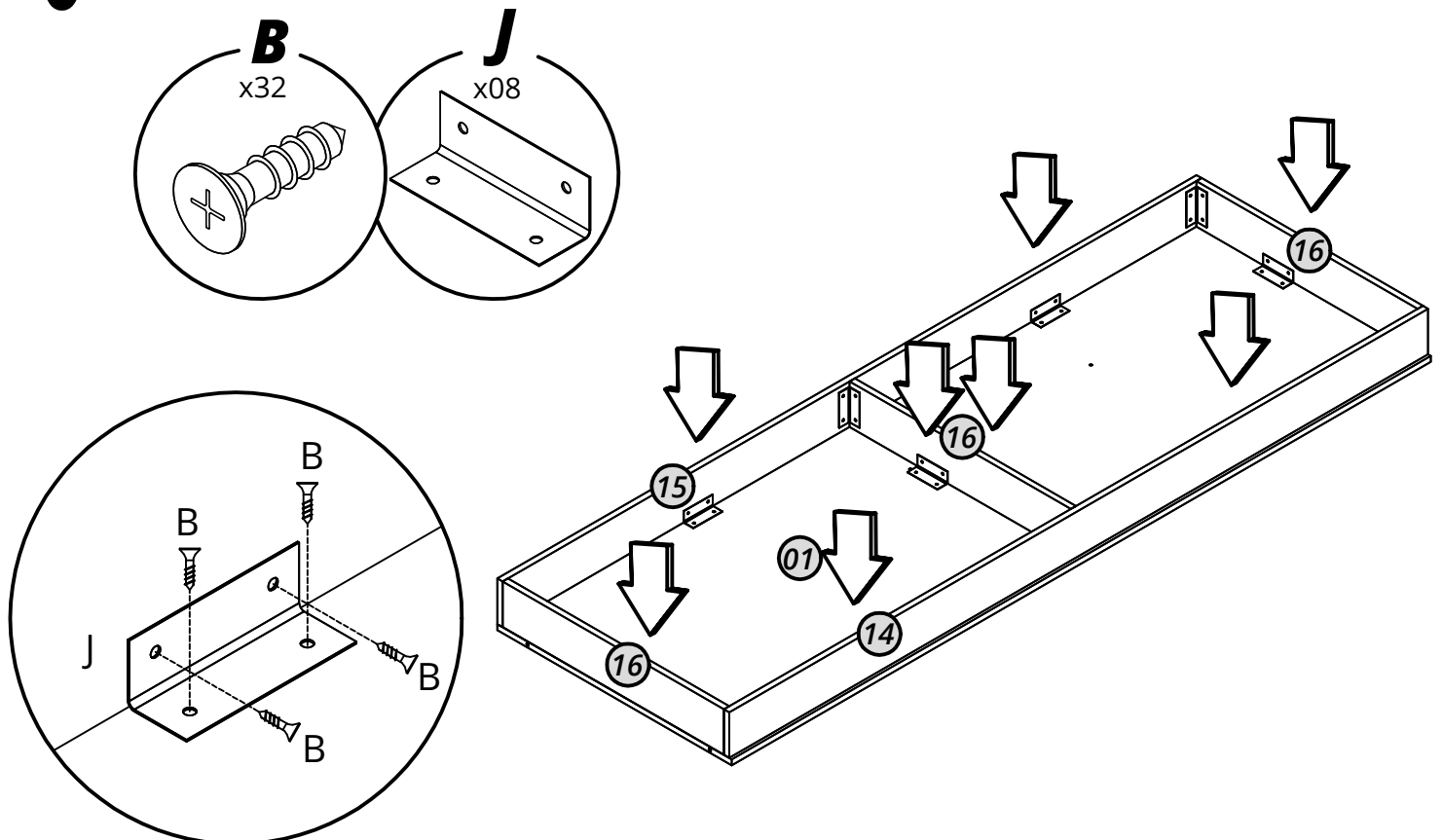

03

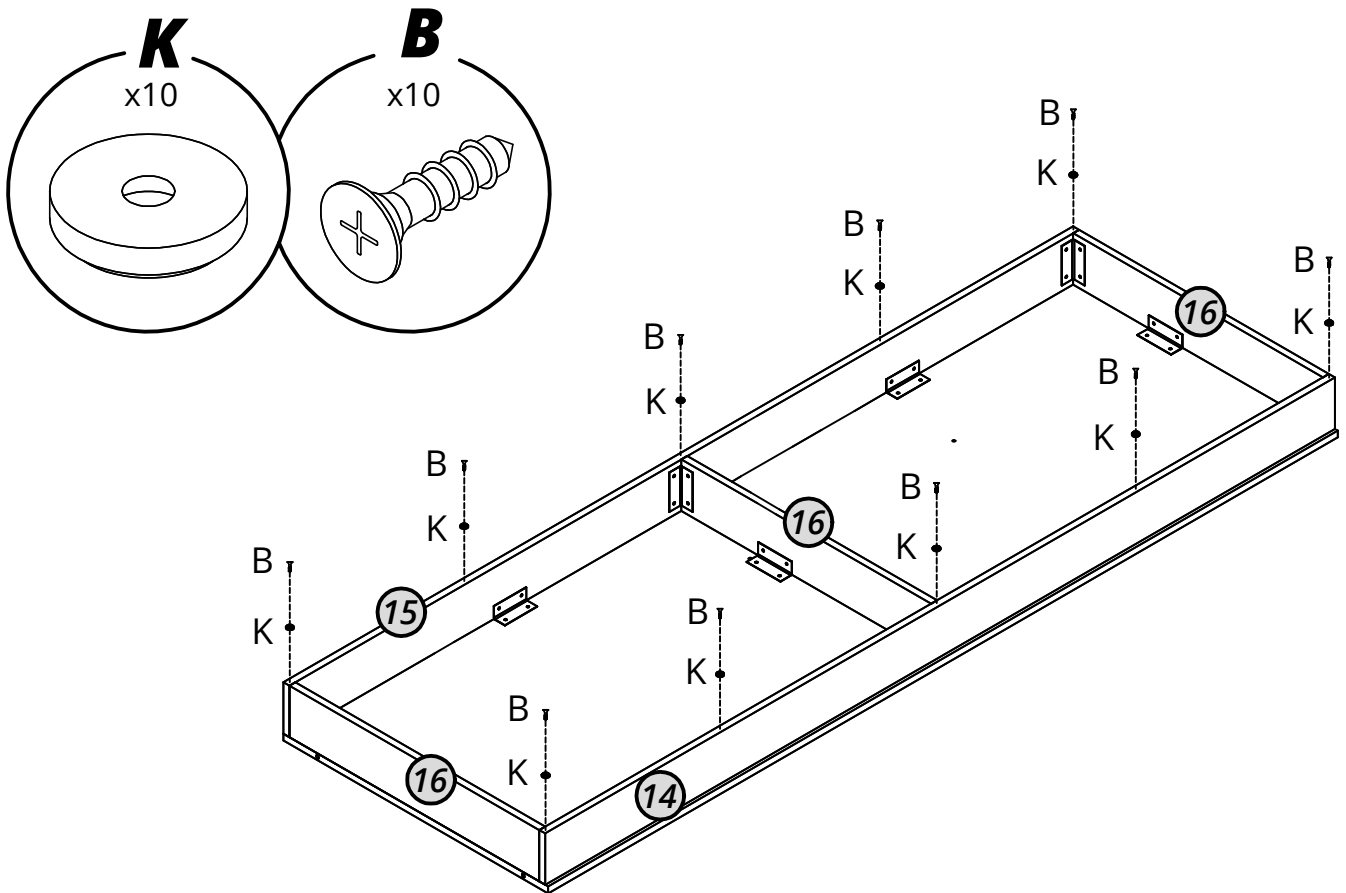

04

Atenção: Kit pé é opcional. Vendido separadamente. Use os parafusos do próprio kit para fixá-lo.

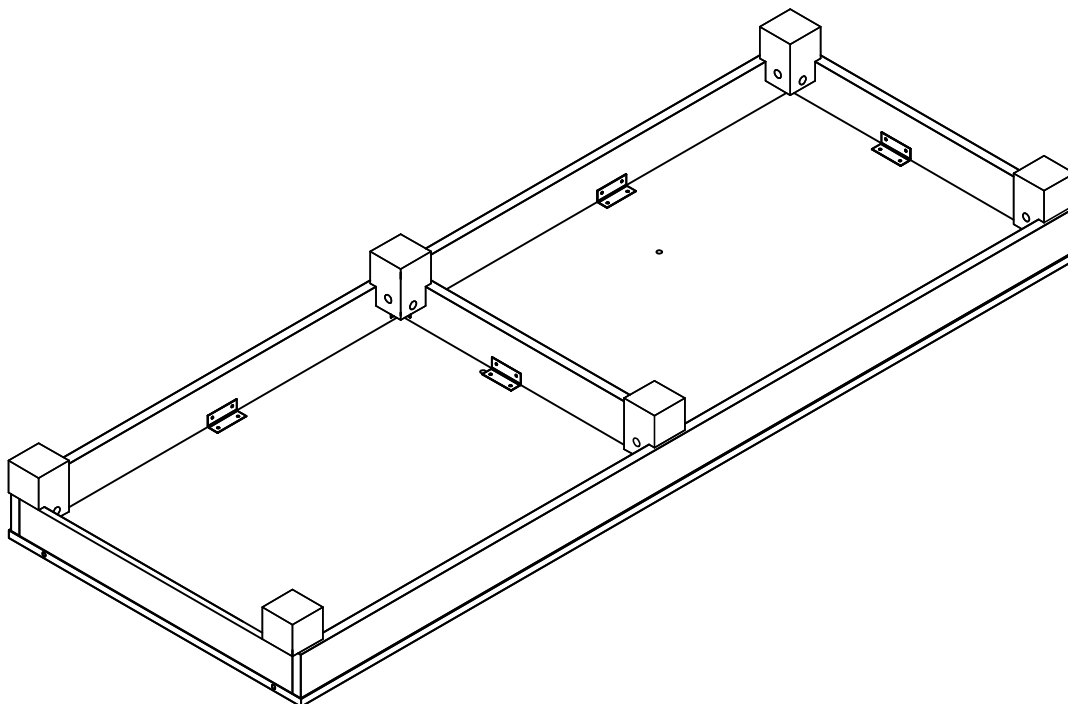

05

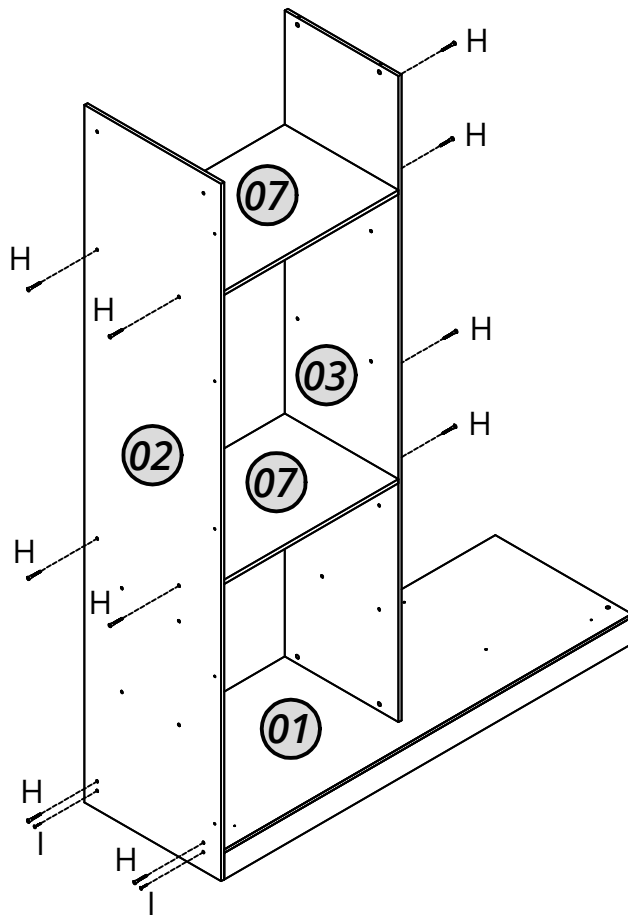
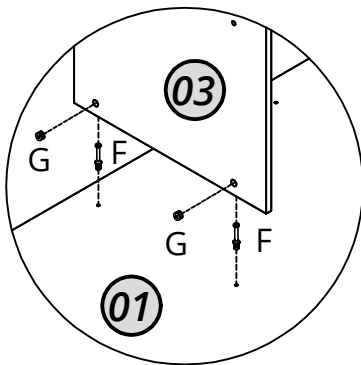
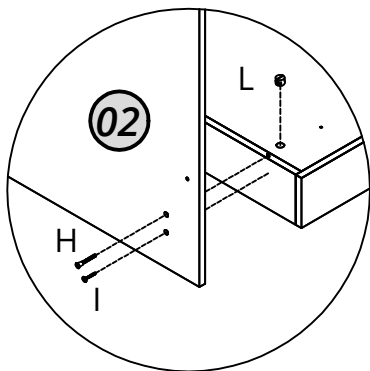
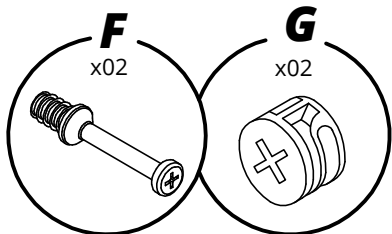
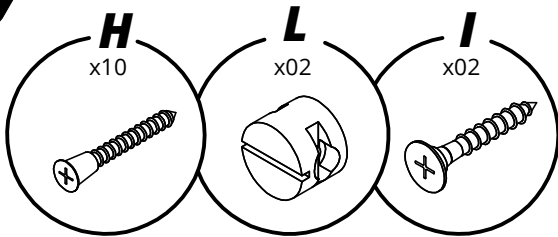

06

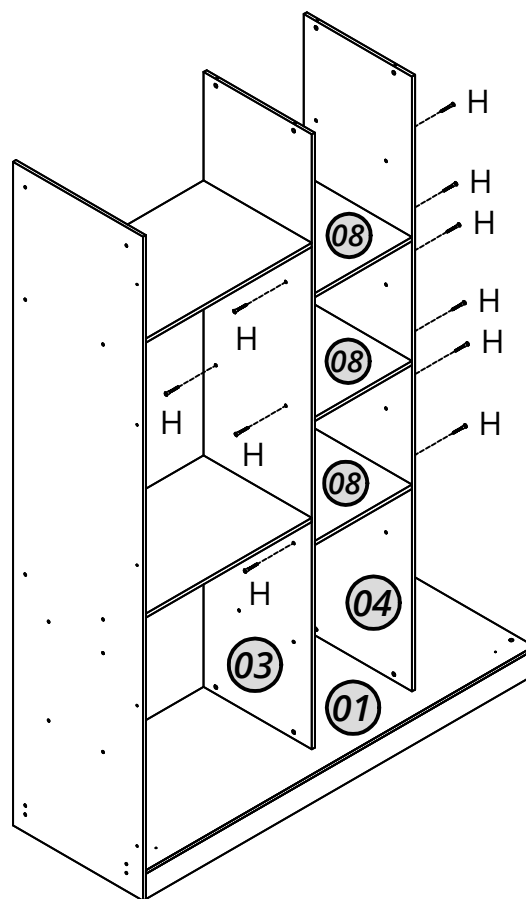
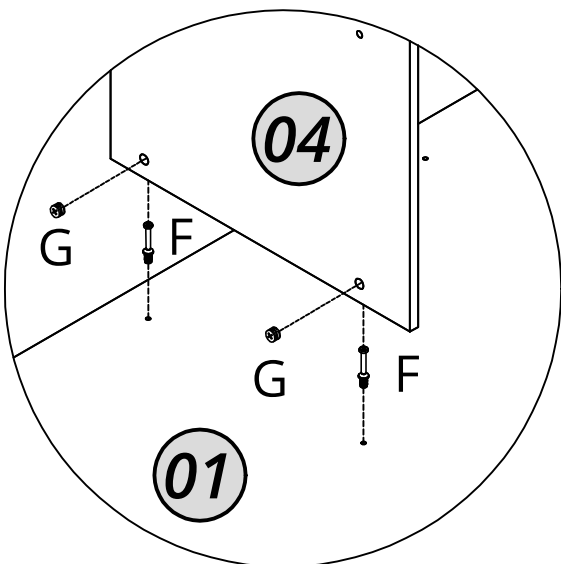
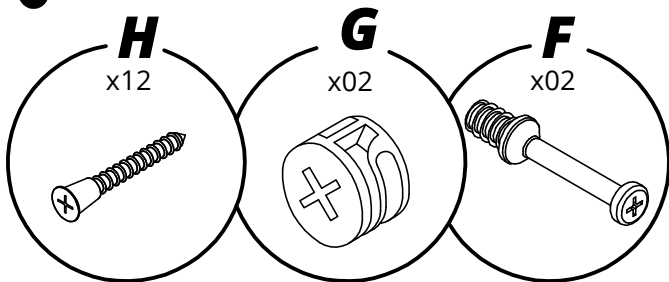

07

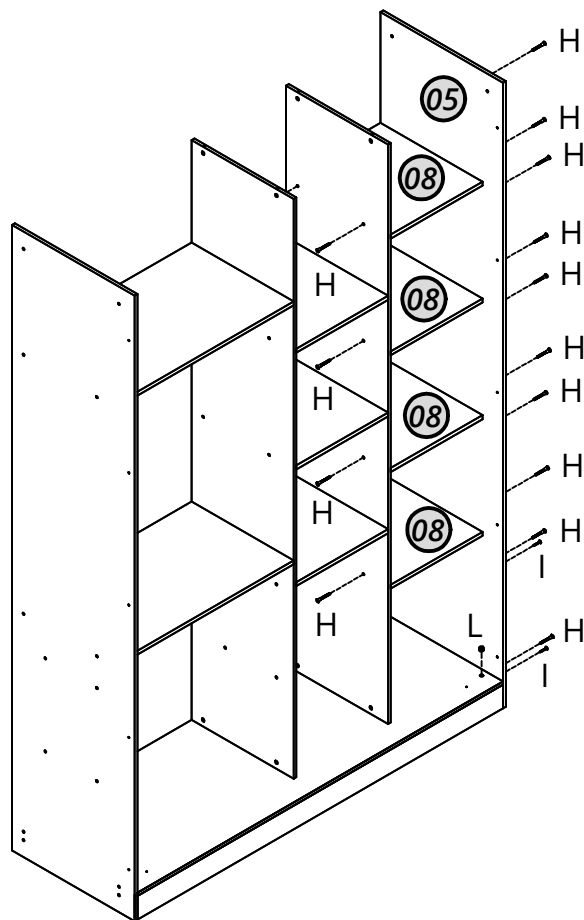
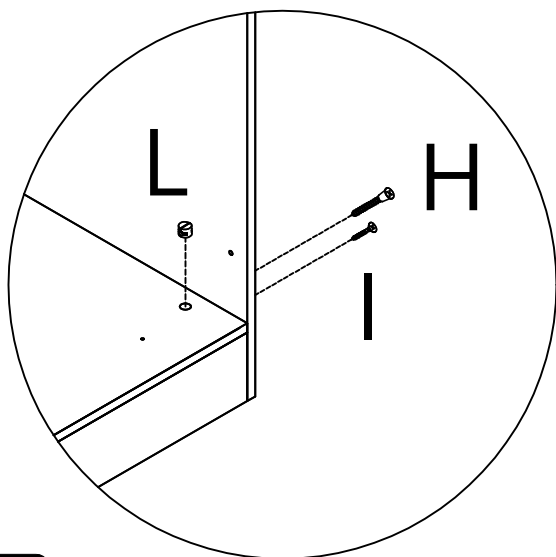
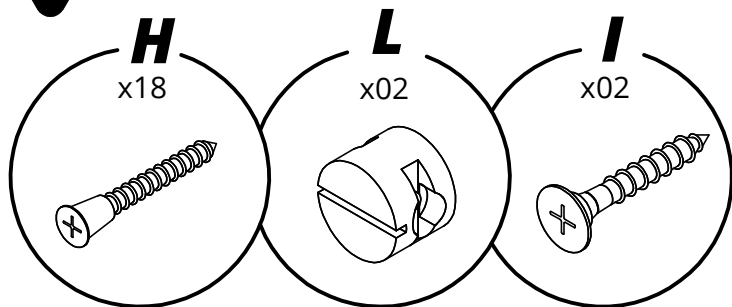

08

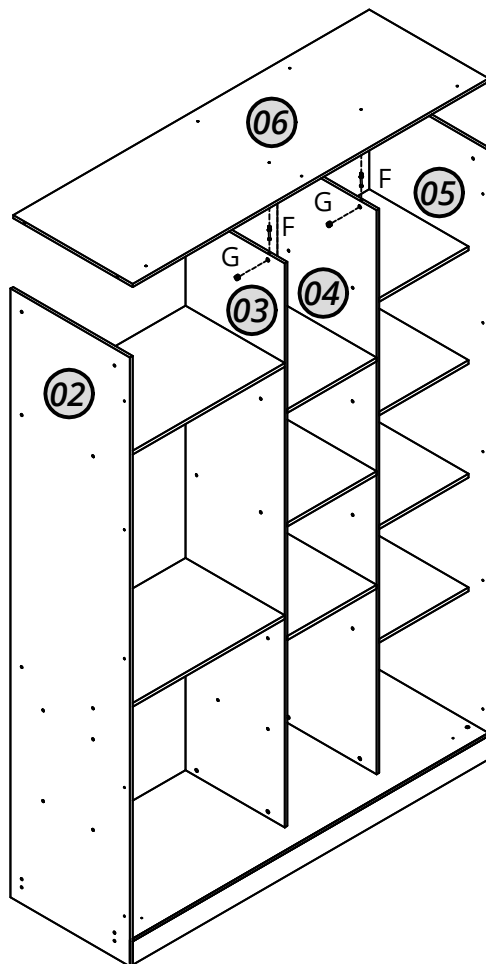
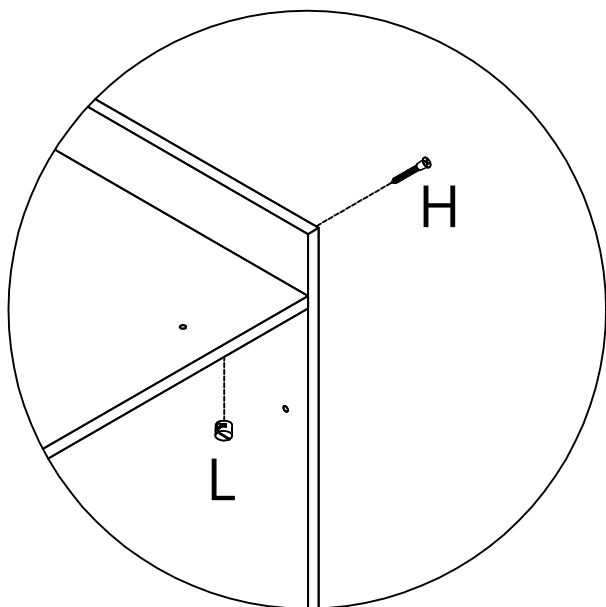
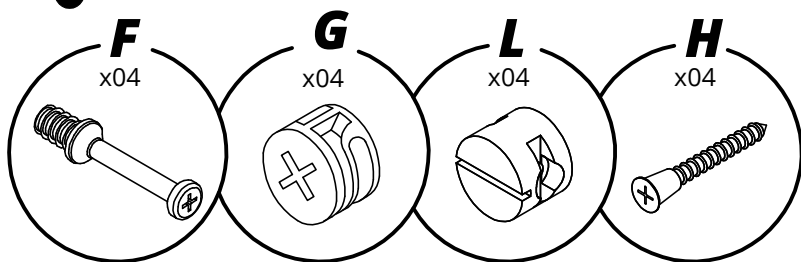

09

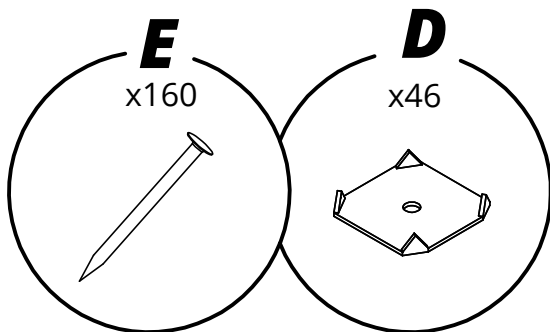

Atenção: Recomendamos pregar os fundos nas prateleiras também.

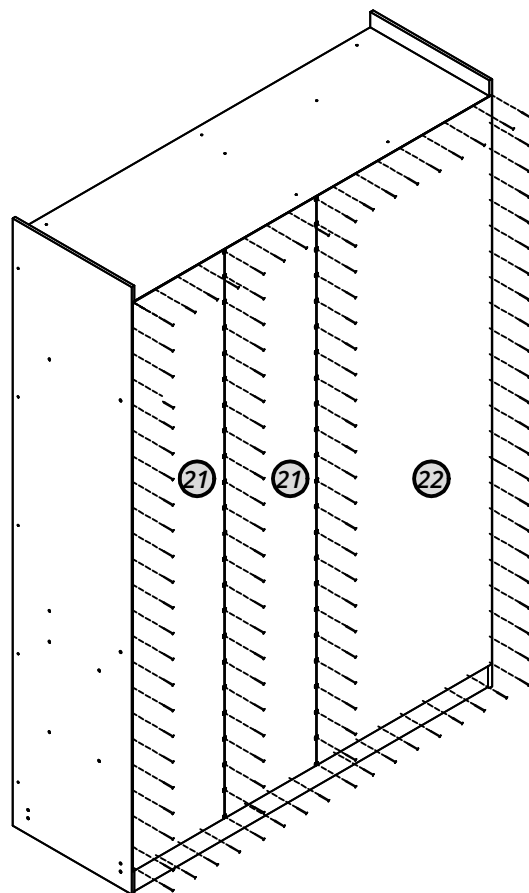
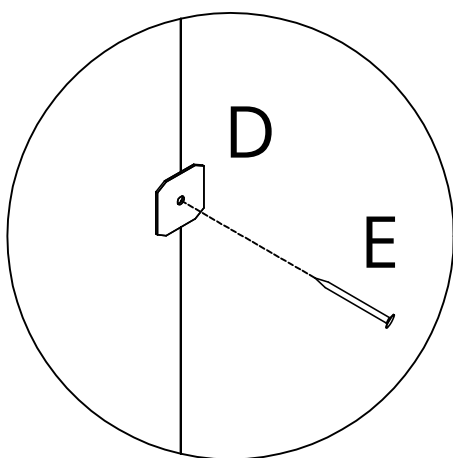

10

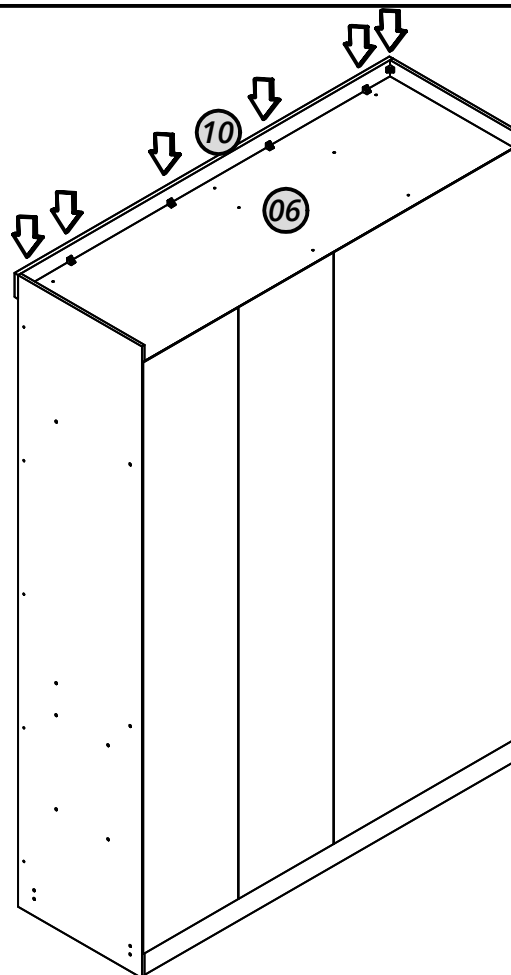
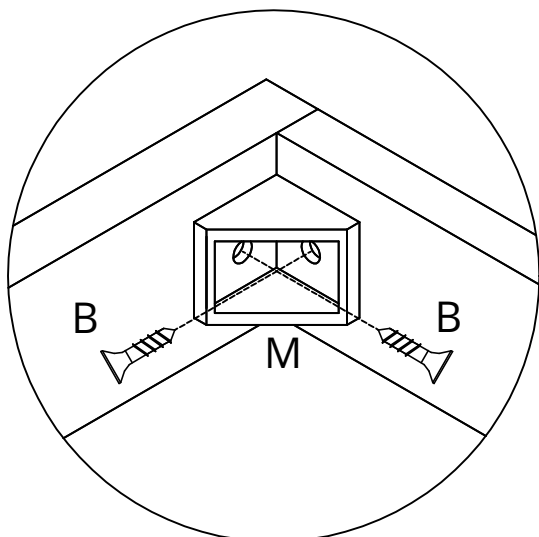
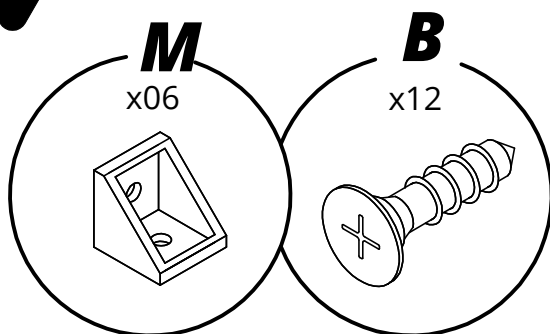

11

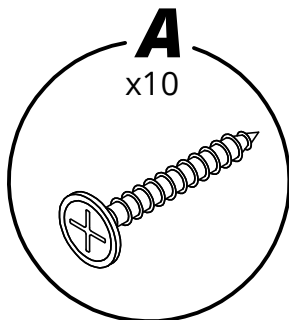

Atenção: Alinhar a régua lateral com a moldura, assim como mostra a imagem abaixo.

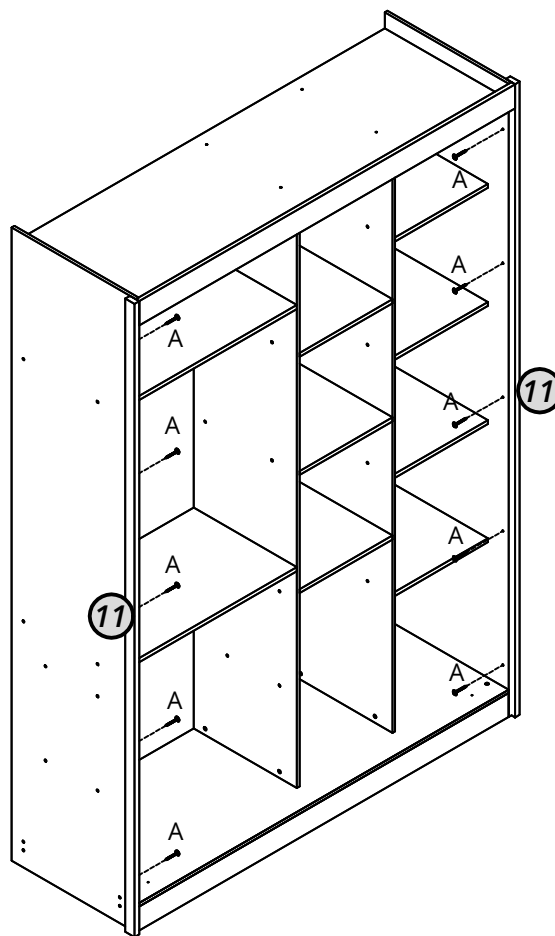
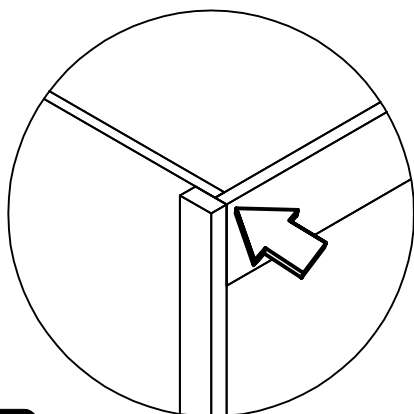

12

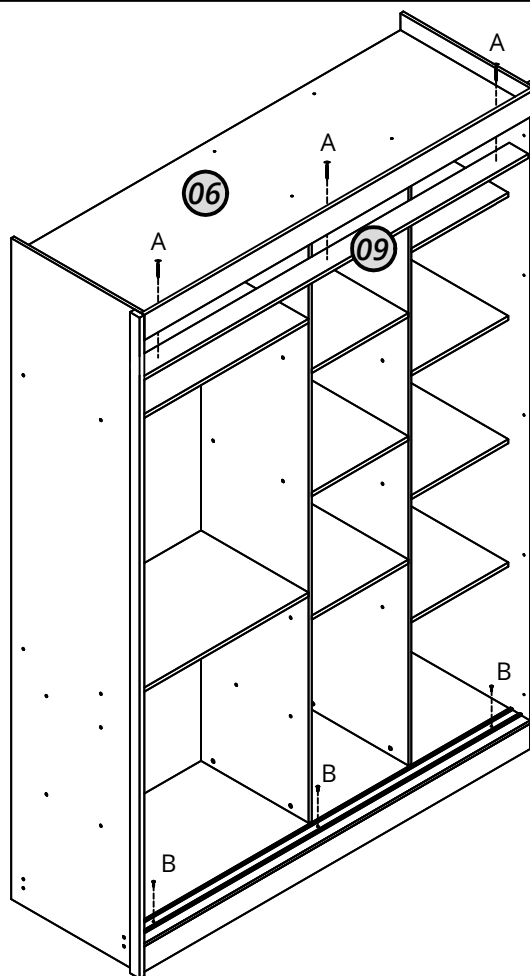
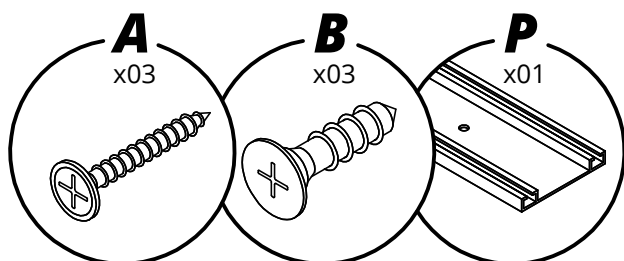

13

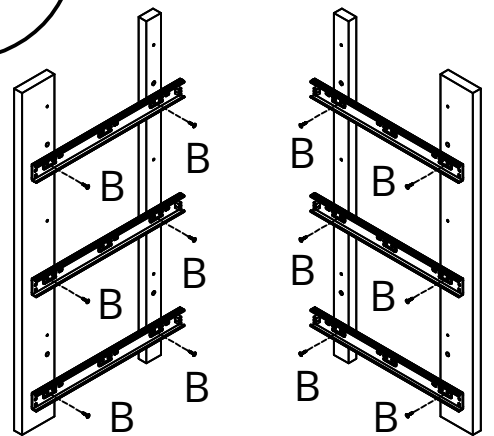
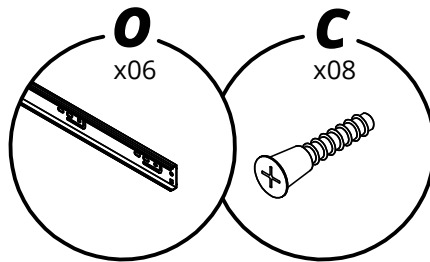
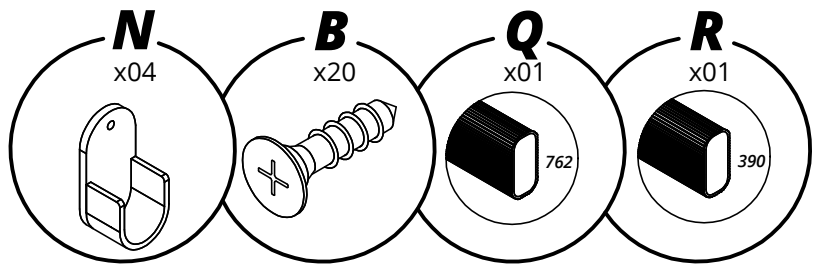
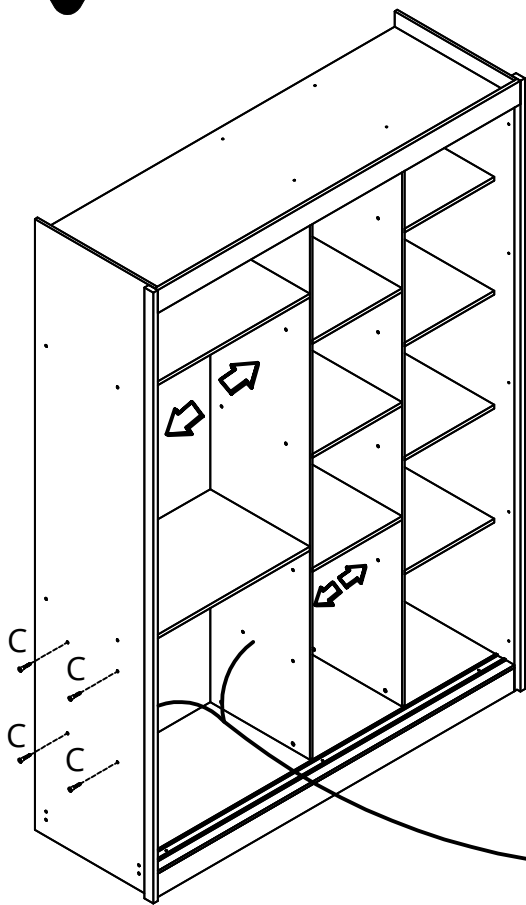

14

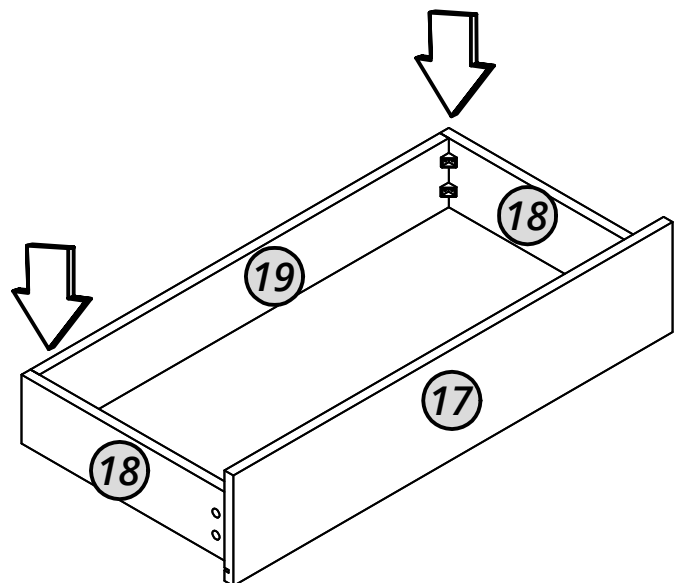
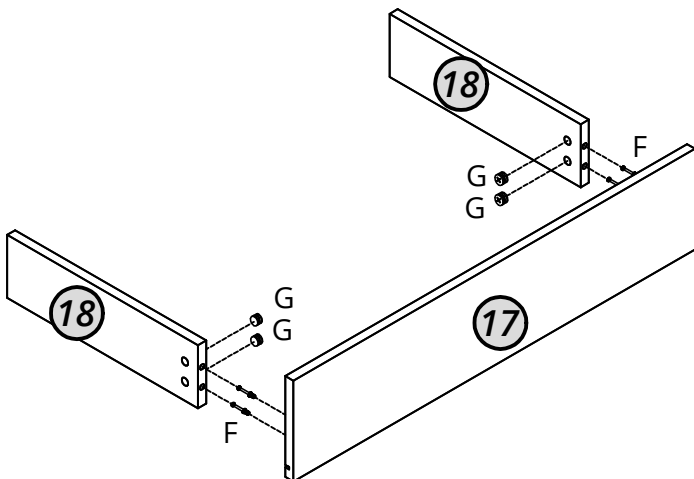
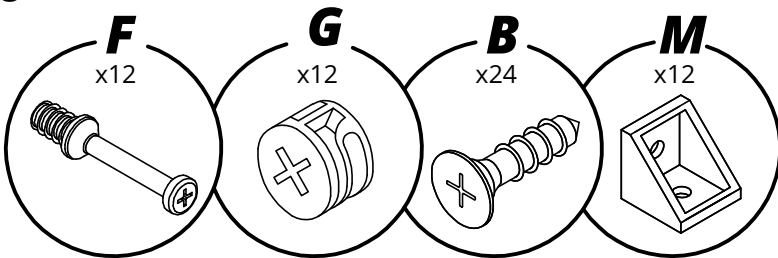

15

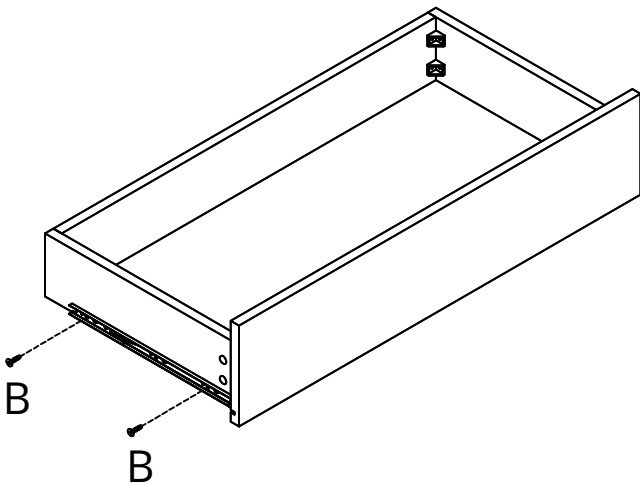
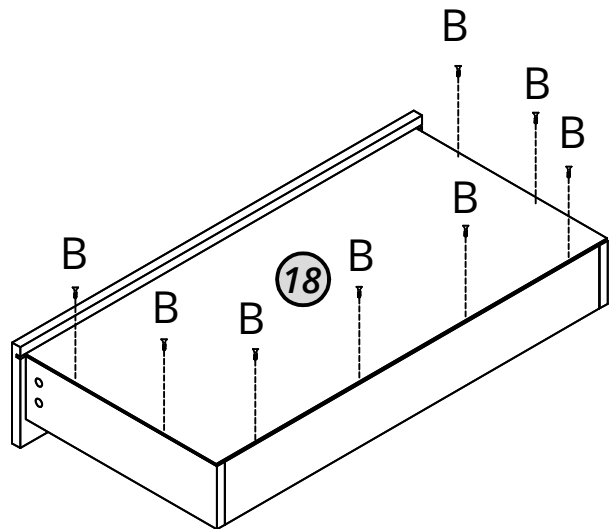
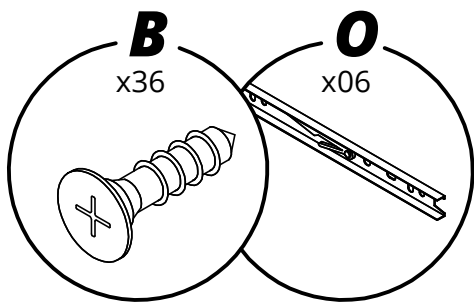

16

Atenção: Fixar os puxadores e as roldanas com os parafusos que vem no próprio kit.

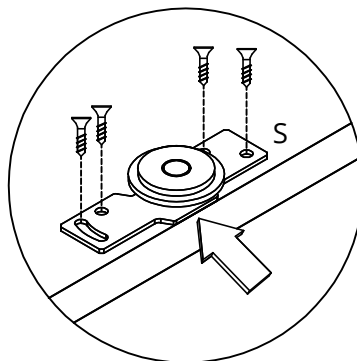
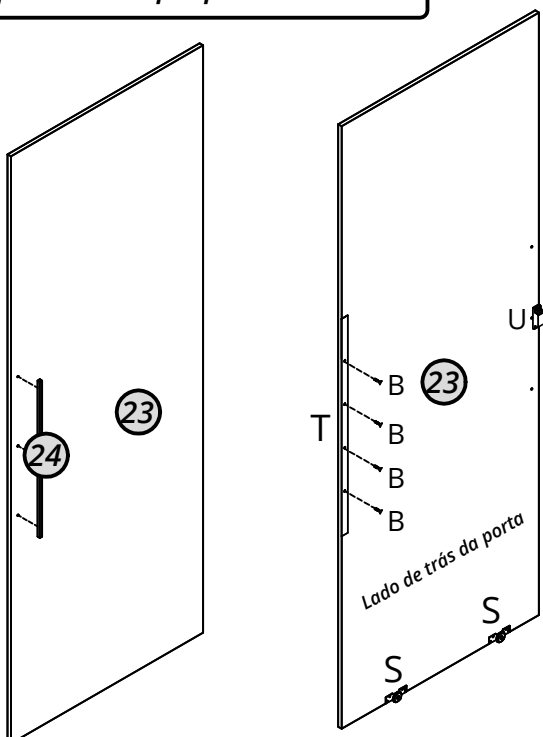
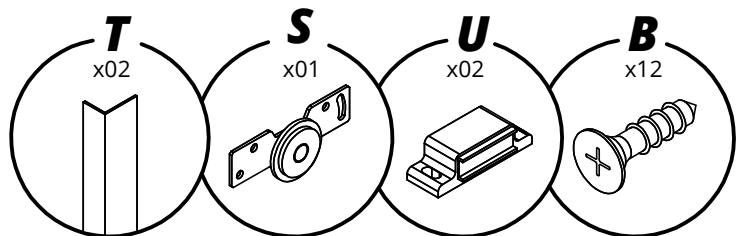

Alinhar as roldanas como mostra a imagem.

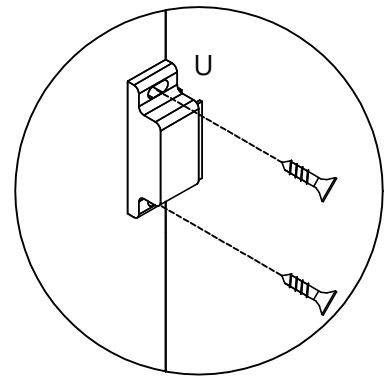

Aplicar as chapinhas do ima nas laterais.