

Nº	Cód.	Peças	Piezas	Parts	Medida / Size	Qtd.	Vol.
01	08277	Base	Base	Base	2269x445x15	01	02
02	08279	Lateral esquerda	Lateral izquierda	Left side	2335x445x15	01	01
03	08281	Divisoria esq. / dir.	División	Division	1733x445x15	02	02
04	08278	Tampo	Cubierta	Top	2269x445x15	01	02
05	08280	Lateral direita	Lateral derecha	Left right	2335x445x15	01	01
06	08282	Tampo intermediario	Cubierta intermediario	Intermediary top	2269x445x15	01	02
07	08283	Prateleira	Estante	Shelf	746x445x15	07	03
08	08284	Rodape frontal	Rodapie frontal	Lower front crossbar	2269x80x15	01	01
09	08285	Rodape traseiro	Rodapie trasero	Lower rear crossbar	2269x80x15	01	01
10	08286	Trava do rodape	Traba del rodapie	Smaller crossbar	410x80x15	04	01
11	08287	Moldura	Marco	Frame	2300x80x15	01	01
12	08288	Regua prateleira	Regla del estante	Shelf ruler	740x40x15	01	03
13	08289	Frente de gaveta	Frente del cajon	Front off drawer	699x160x15	04	03
14	08290	Lateral de gaveta	Lateral de cajon	Side off drawer	350x100x15	08	03
15	08291	Contra fundo de gaveta	Trasero del cajon	Rear off drawer	654x100x15	04	03
16	08292	Divisão superior	División superior	Upper division	399x92x15	02	01
17	08293	Perfil H	Perfil H	Profile H	1733x40x6	03	01
18	08294	Distanciador frontal	Espaciador frontal	Front spacer	374x63x18	04	03
19	08295	Distanciador traseiro	Espaciador trasero	Rear spacer	374x28x18	04	03
20	08296	Fundo de gaveta	Fondo del cajone	Bottom off the drawer	684x355x2,5	04	03
21	08297	Fundo maior	Fondo más mayor	Bigger bottom	2298x422x2,5	01	01
22	08298	Fundo menor	Fondo menor	Smaller bottom	1755x370x2,5	06	01
23	08274	Portas	Puertas	Doors	2170x378x15	06	01
24	08275	Puxador	Tirador	Handle	1130x30x22	06	01
25	30019551	Kit pé	Kit Píe	Foot kit		08	03

Recorte aqui e guarde seu certificado de garantia!

# Certificado de garantia

A Gelius Indústria de Móveis confia na qualidade de seus produtos e por isso o garante pelo prazo de 90 dias para defeitos de fabricação em condições normais de uso.

Resultarão nula a garantia e sem efeito a cobertura, se o produto, (incluindo vidros e ou espelhos que o compõe):

- sofrer dano provocado por acidente, agente da natureza.
- uso indevido ou maus tratos como arrastar, subir em cima, colocar produtos com excesso de peso).
- não utilizado para os fins a que se destina.
- conter manchas provocadas por uso de produtos químicos em sua limpeza.
- excesso de umidade ou água.

Ao detectar qualquer defeito em seu móvel, entre em contato com a loja onde foi efetuada a compra. A comprovação de que o móvel a ser consertado ou substituído encontra-se dentro do prazo de garantia é de total responsabilidade do fabricante e deve ser feita mediante a apresentação desse certificado corretamente preenchido e sem rasuras ou resalvas.

Cuidados com seu móvel Gelius!

- para limpeza do seu móvel, utilize apenas pano macio e seco.
- jamais limpe-o com palha de aço, álcool ou qualquer outro produto químico ou abrasivos, óleos de peroba ou produtos do gênero.
- evite deixá-lo sob raios solares ou chuva.
- ao transportar o seu móvel Gelius, prenda-o firmemente para que não ocorra quedas indesejáveis.

Seguindo corretamente as informações acima, você conservará por muito mais tempo o seu móvel Gelius!

GARANTIA DO CLIENTE:

Cliente: \_\_\_\_\_

Rua: \_\_\_\_\_ Nº: \_\_\_\_\_ Bairro: \_\_\_\_\_

Cidade: \_\_\_\_\_ UF: \_\_\_\_\_ Loja onde comprou: \_\_\_\_\_

Data da compra: \_\_\_\_/\_\_\_\_/\_\_\_\_ Nota Fiscal: \_\_\_\_\_

Data da reclamação na loja: \_\_\_\_/\_\_\_\_/\_\_\_\_

Defeito constante: \_\_\_\_\_

## Recomendações | Recomendaciones | Recommendations

**Atenção**  
 Atención  
 Attention

**Este produto deve ser montado por um profissional.**

Este producto debe ser ensamblado por un profesional.

This product must be assembled by a professional.

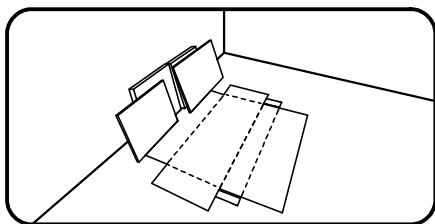

**Antes de começar a montagem prepare o ambiente, deixando-o completamente limpo e com bom espaço para iniciar o trabalho. Utilize o papelão da própria embalagem para separar e apoiar as peças retiradas da caixa.**

Antes de comenzar el montaje preparar el ambiente, dejándolo completamente limpio y con buen espacio para comenzar el trabajo. Utilice el cartón de la embalaje para separar y apoyar las piezas desmontadas de las cajas.

Prepare the room before starting the assembly, leaving it completely clean and the area in good condition to start the work. Use the cardboard of the packaging to separate and support the parts removed from the boxes.

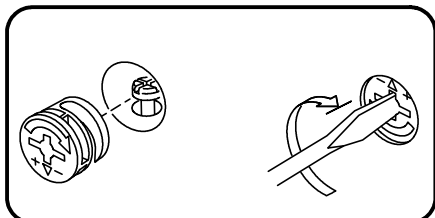

**Como usar o acessório Pino e Tambor Minifix (quando utilizado no produto).**

Como usar el herraje Pino y Tambor Minifix (cuando se usa en el producto).

How to use the Minifix Set (when used in the product).

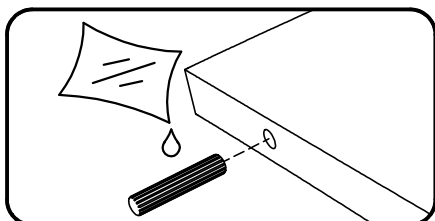

**Aplicar cola nas cavilhas de madeira (quando utilizado no produto).**

Aplicar pegamento a las clavijas de madera (cuando se usa en el producto).

Apply glues to the wooden dowels (when used in the product).

Ferramentas recomendadas para montagem | Herramientas de montaje recomendadas | Recommended tools

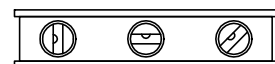
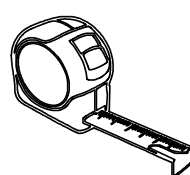
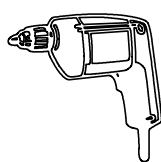
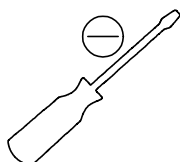
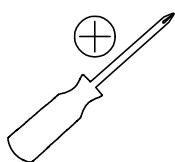

## Acessórios e ferragens | Herrajes | Hardware

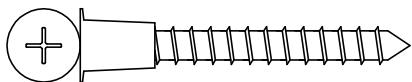

A — cód. 30017779 — 036 un.



B — cód. 30014538 — 172 un.



C — cód. 30014537 — 128 un.

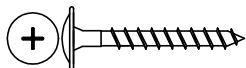

D — cód. 30000843 — 018 un.

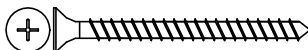

E — cód. 30001098 — 016 un.



F — cód. 30010241 — 004 un.

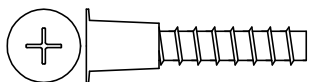

G — cód. 30018169 — 016 un.



H — cód. 30001073 — 032 un.

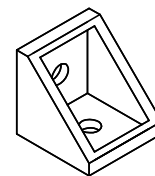

I — cód. 30015224 — 022 un.

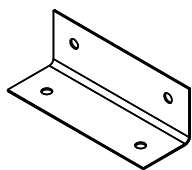

J — cód. 30003829 — 018 un.



K — cód. 30014656 — 004 un.

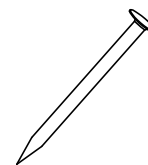

L — cód. 30000783 — 200 un.

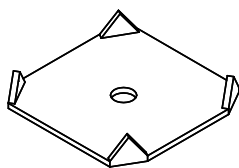

M — cód. 30001164 — 055 un.

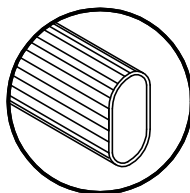

N — cód. 30010340 — 002 un.

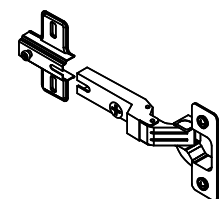

O — cód. 30015486 — 024 un.

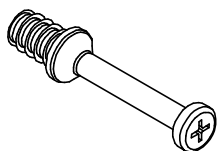

P — cód. 30006753 — 032 un.

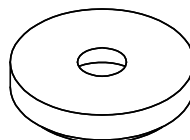

Q — cód. 30000853 — 008 un.

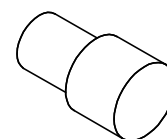

R — cód. 30000797 — 004 un.

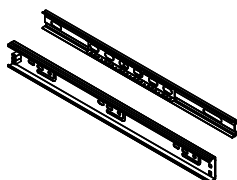

S — cód. 30013843 — 004 un.

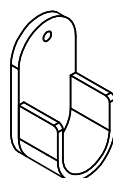

T — cód. 30001188 — 004 un.

01

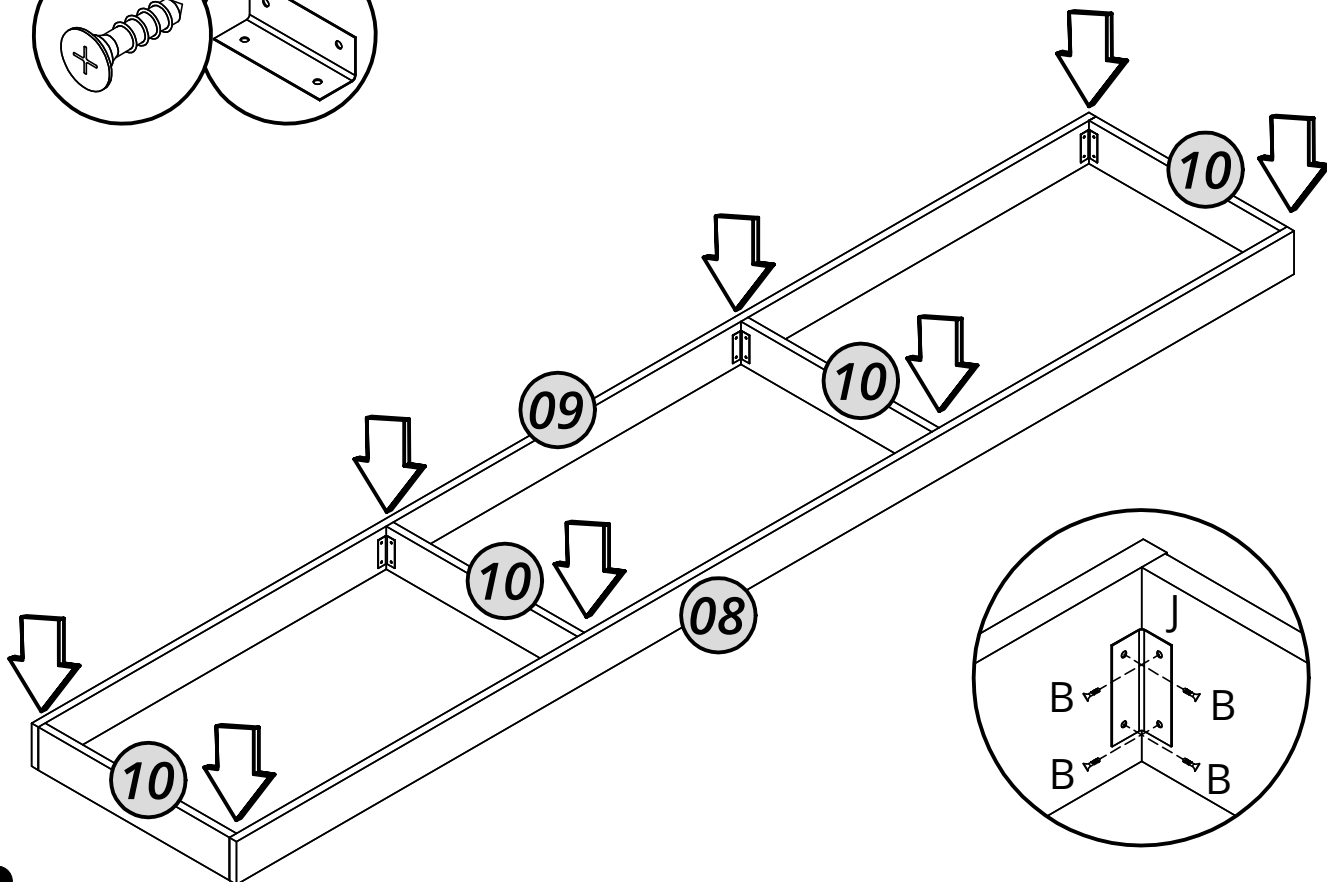
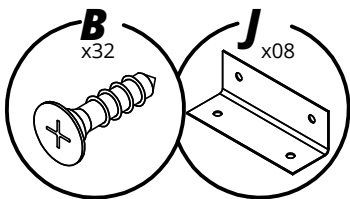

02

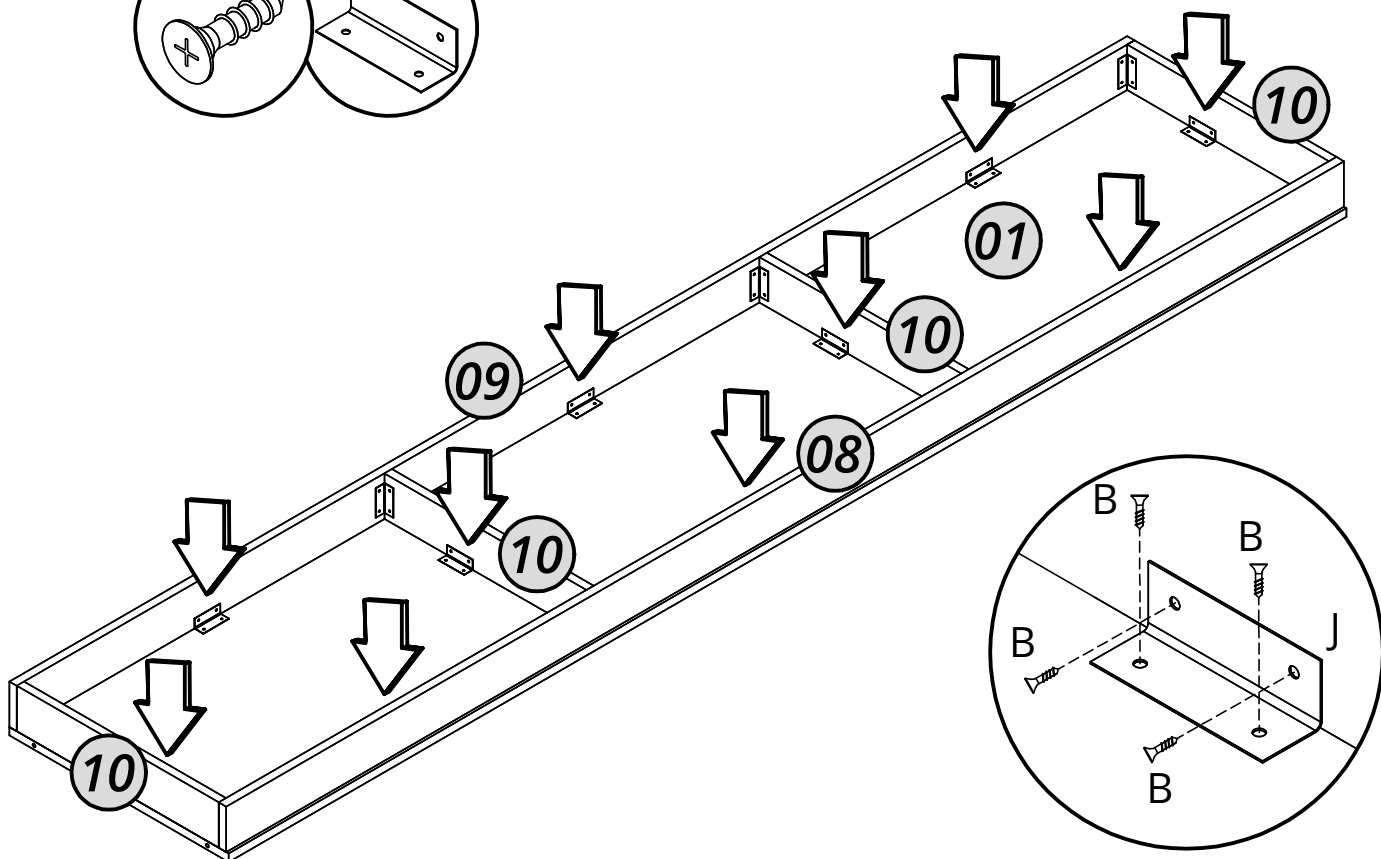
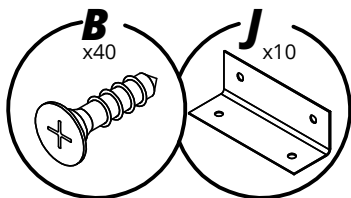

03

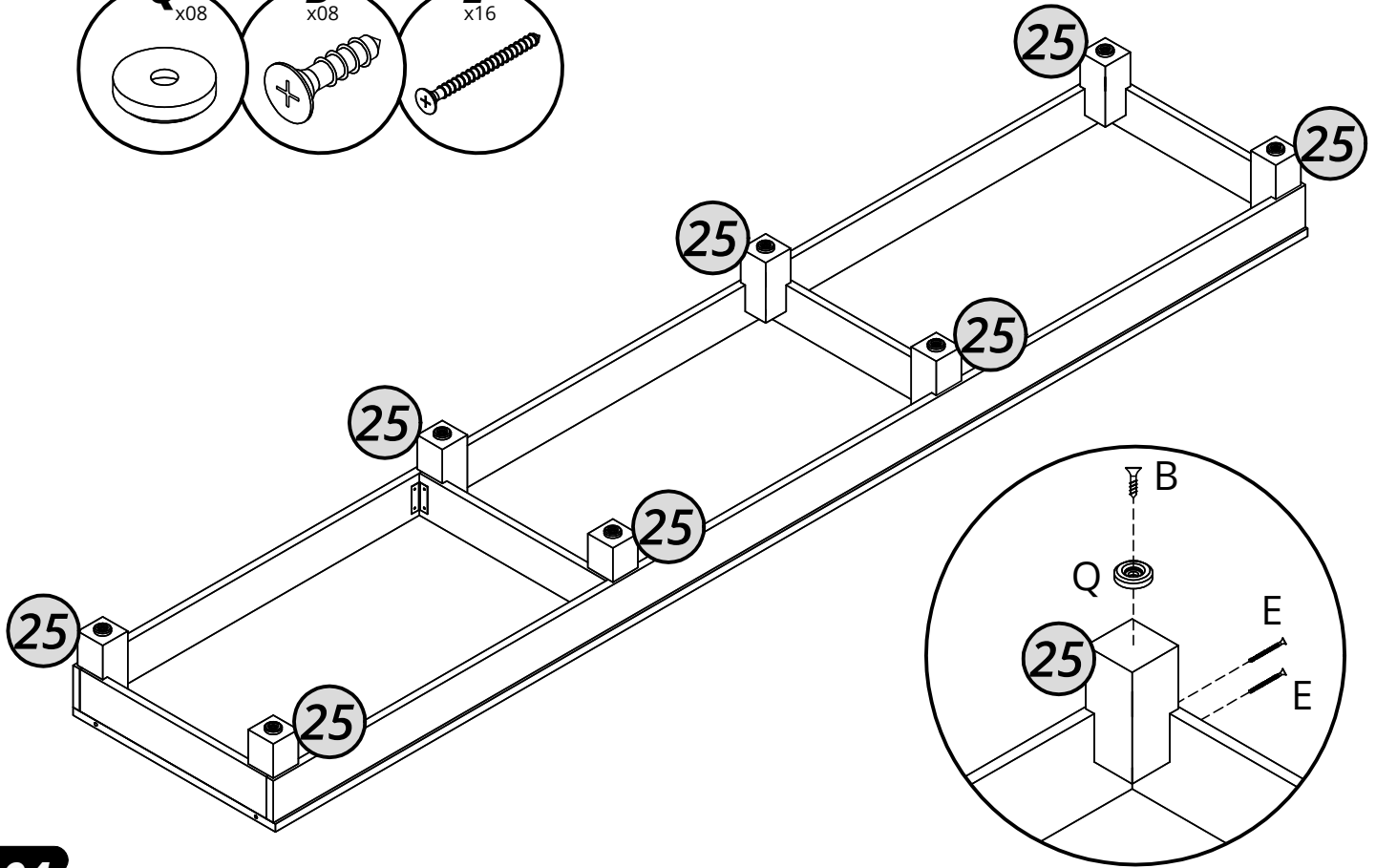
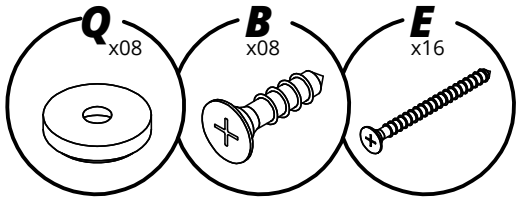

04

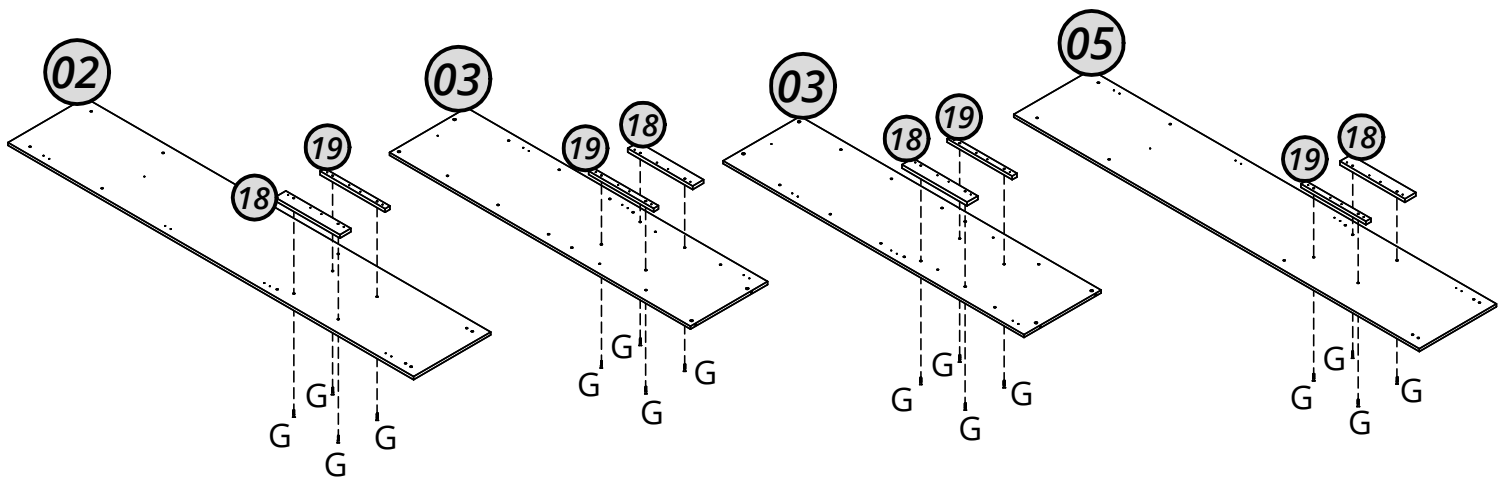
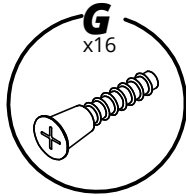

05

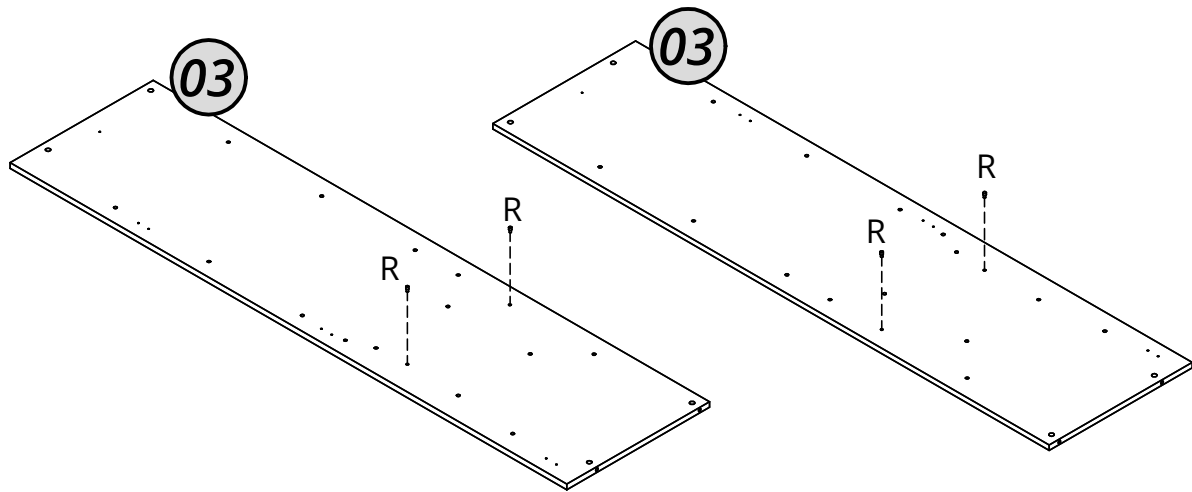
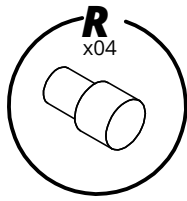

06

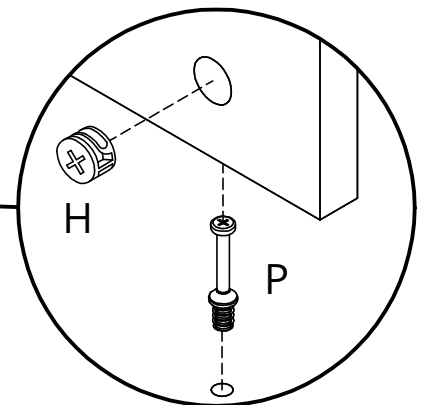
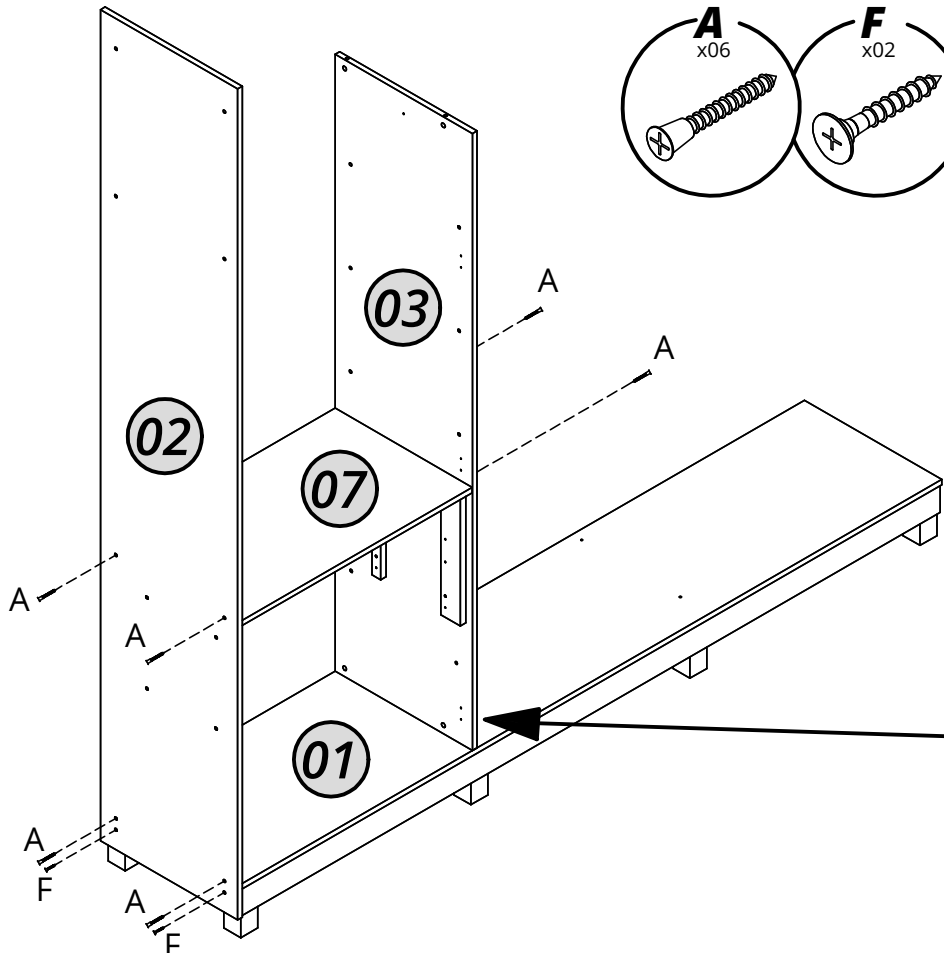
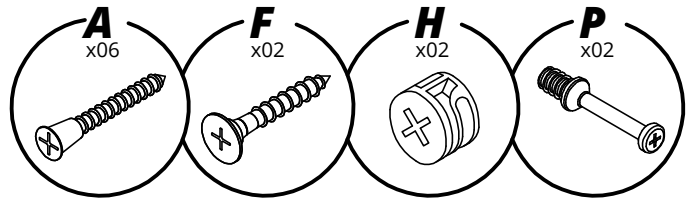

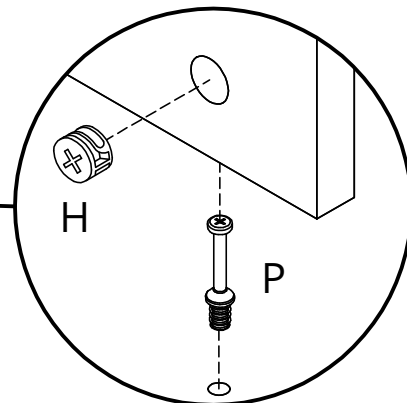
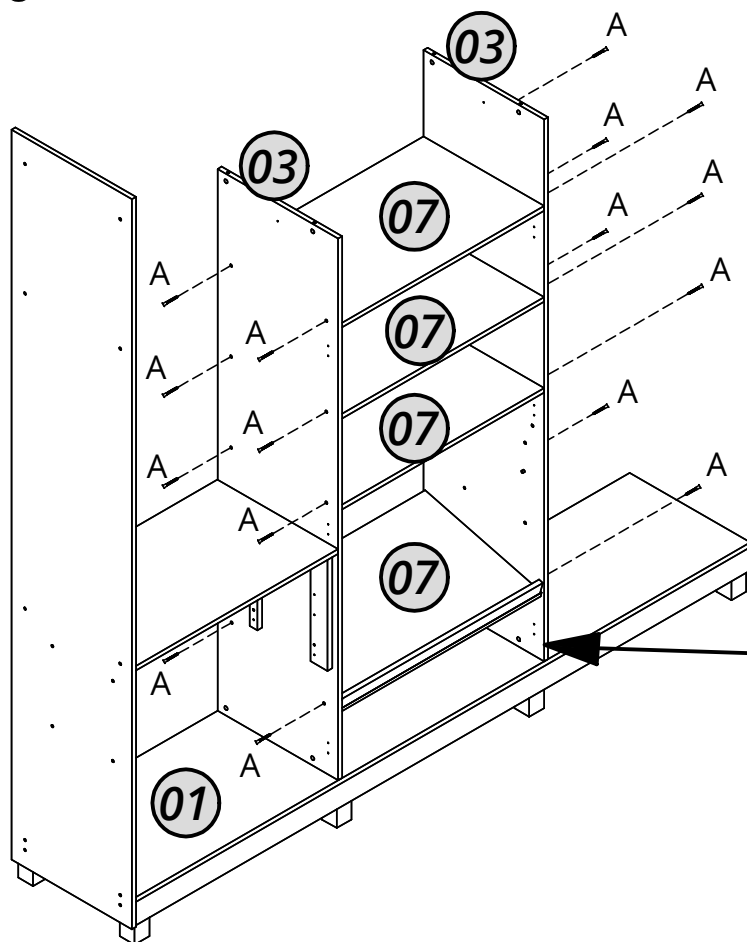
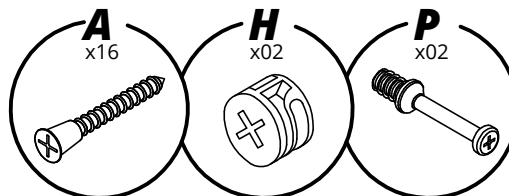
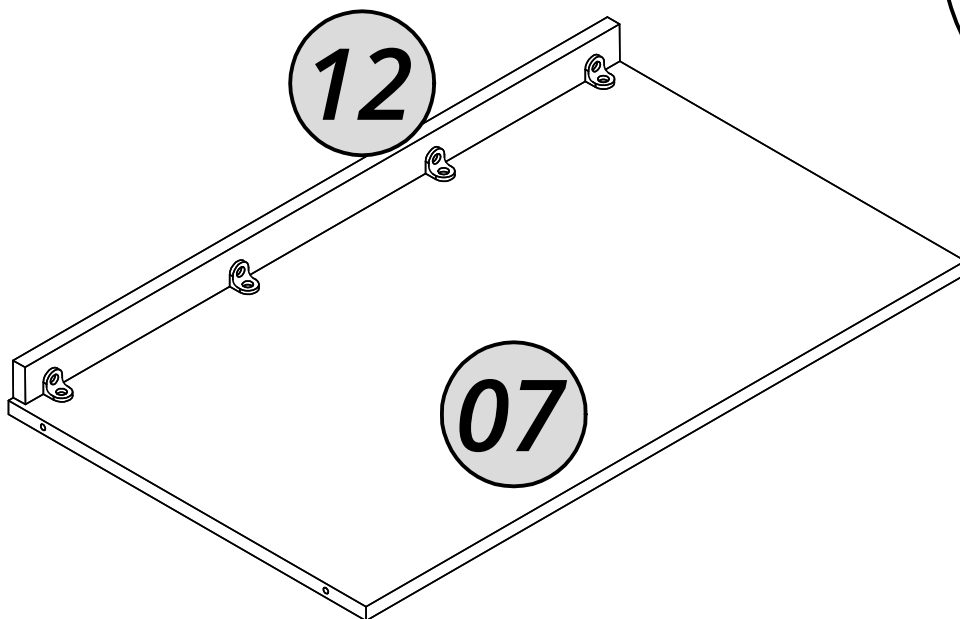
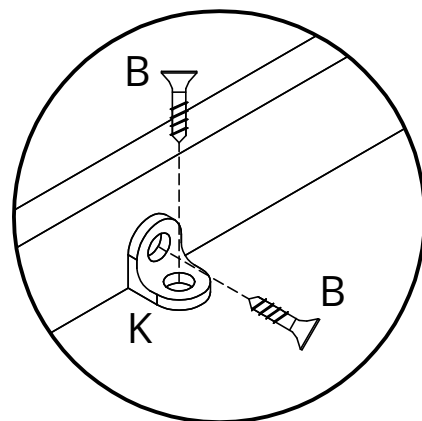
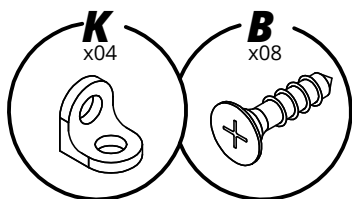

09

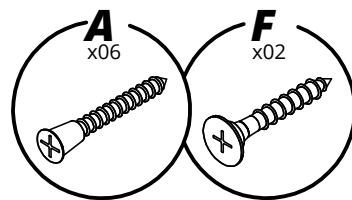
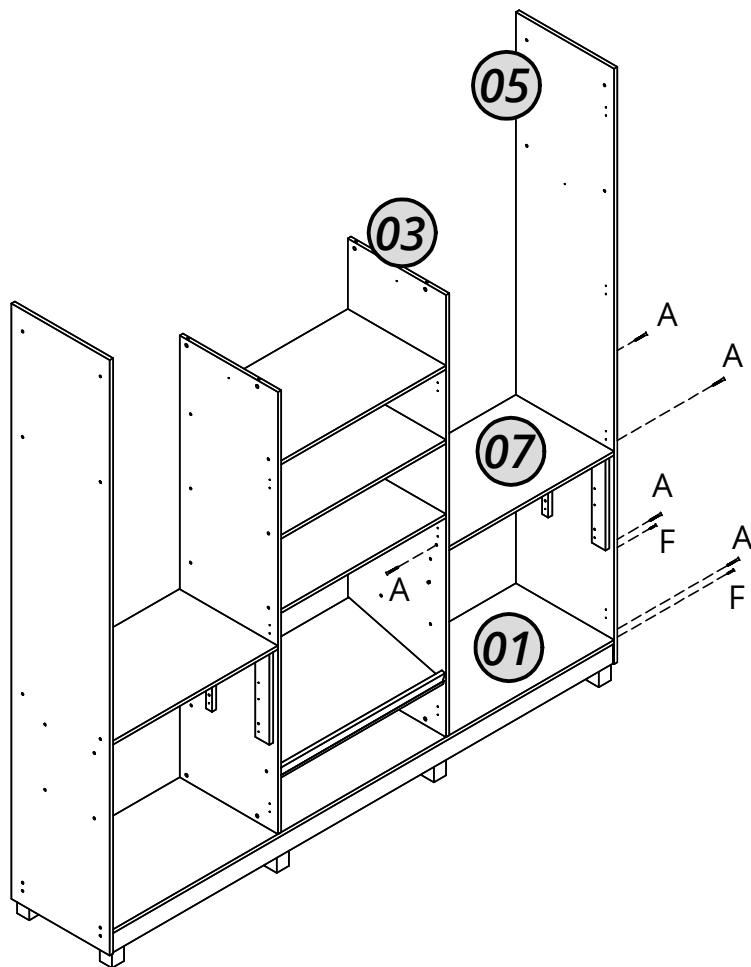

10

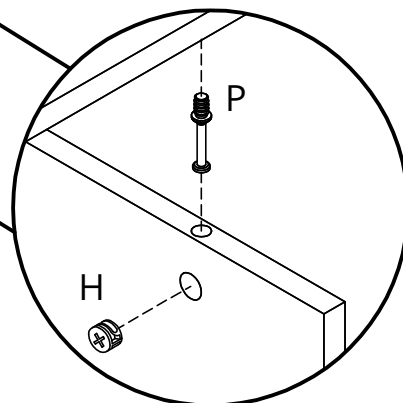
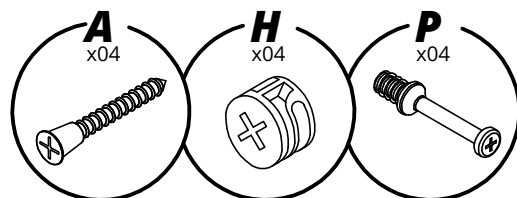
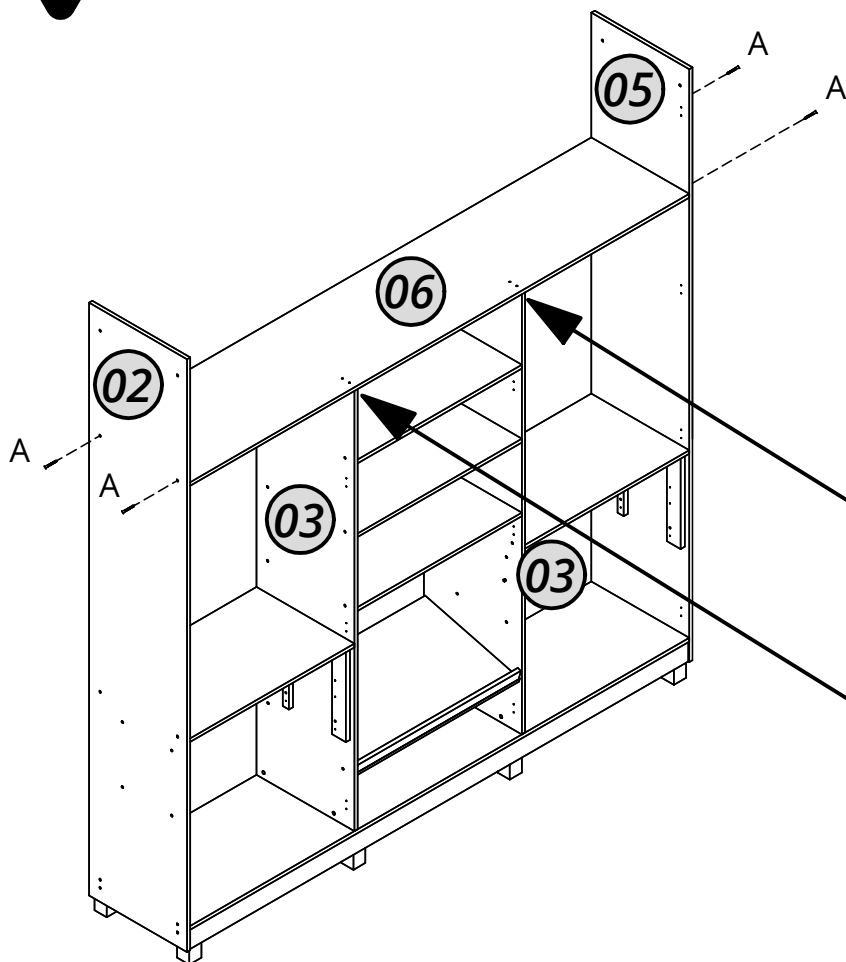



11

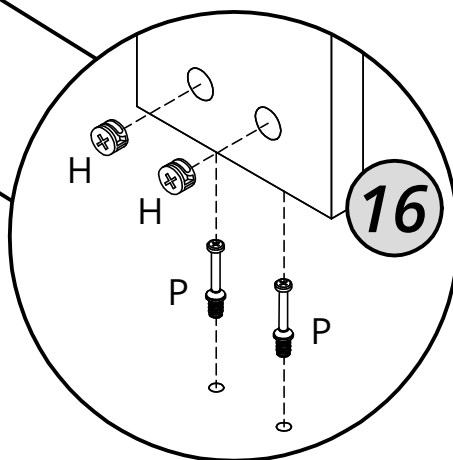
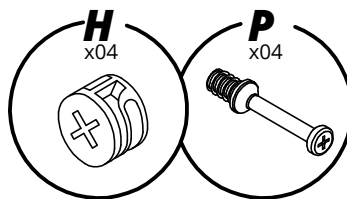
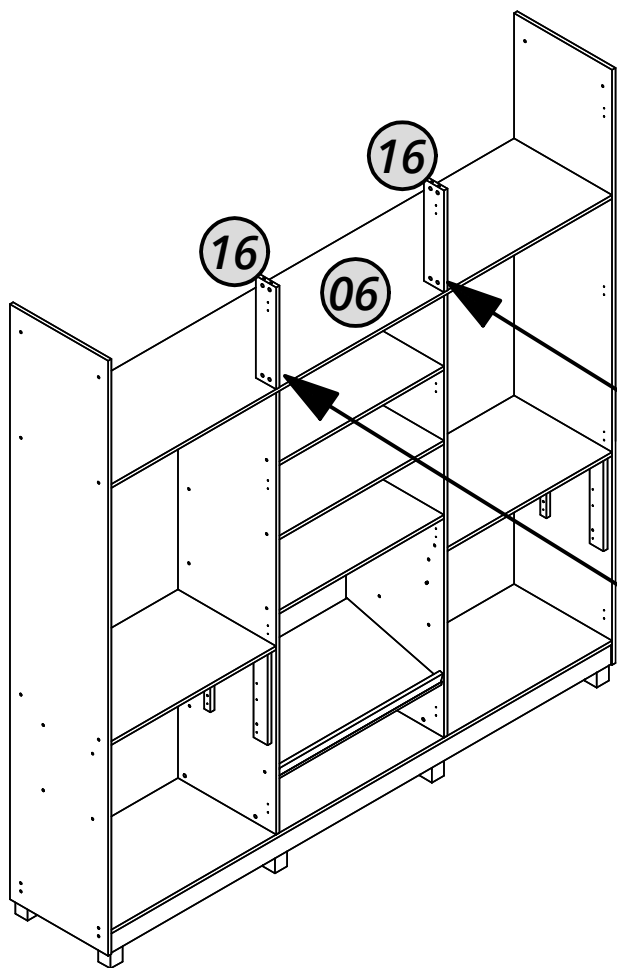

12

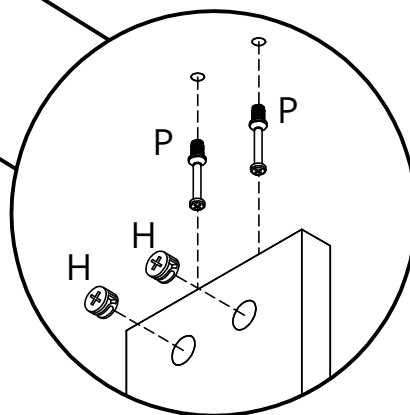
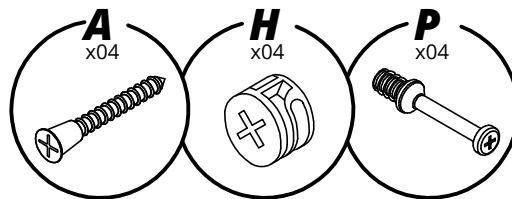
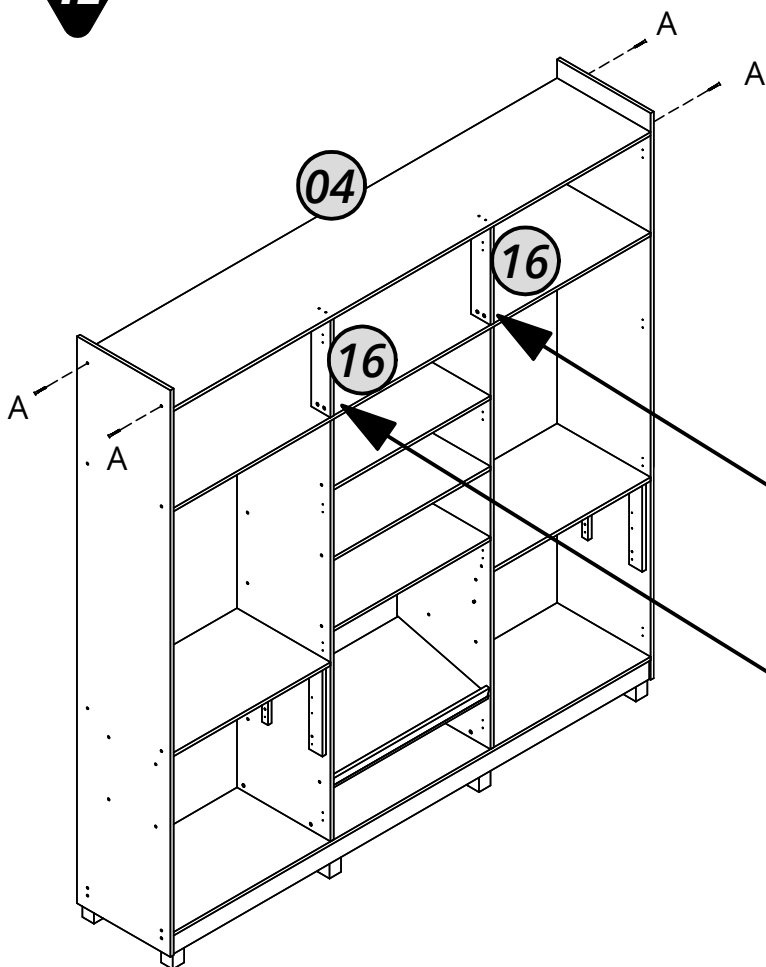

13

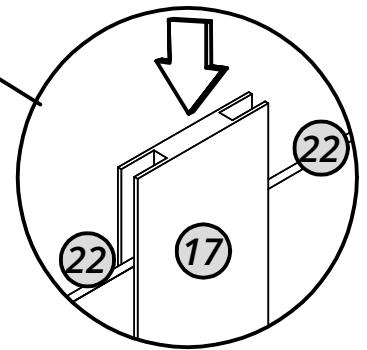
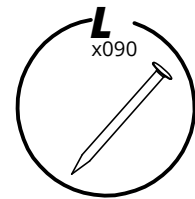
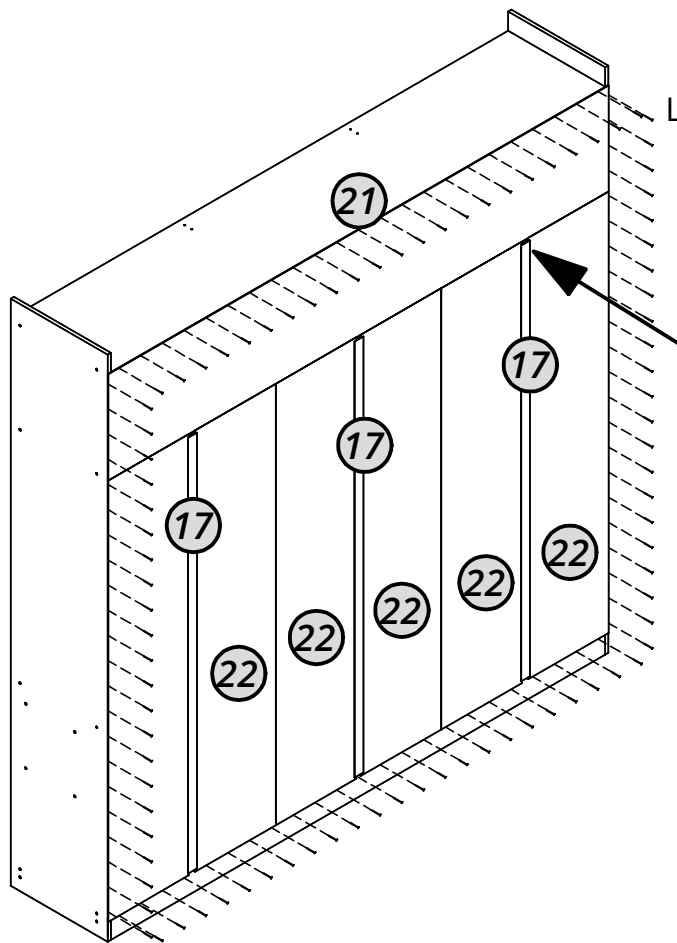

14

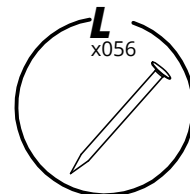
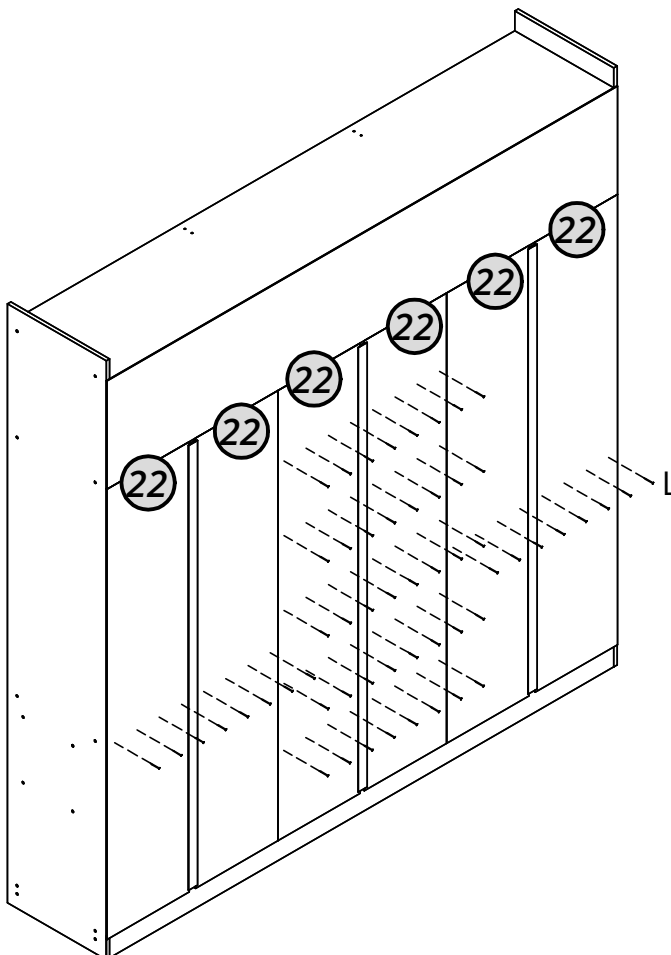

*Atenção: Orientamos também,  
pregar os fundos nas prateleiras.*

15

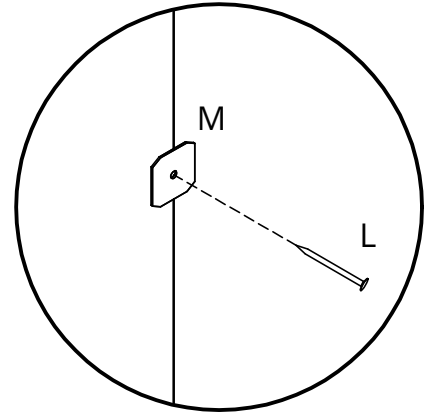
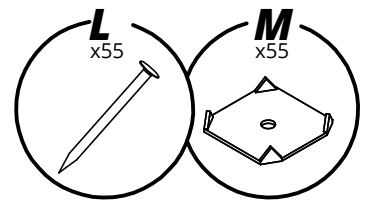
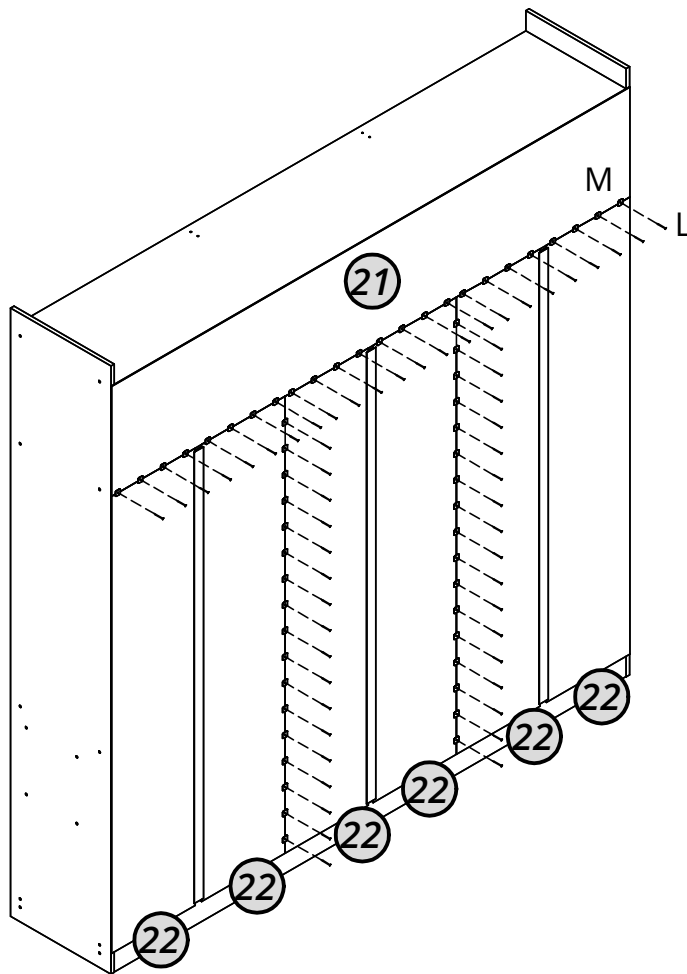

16

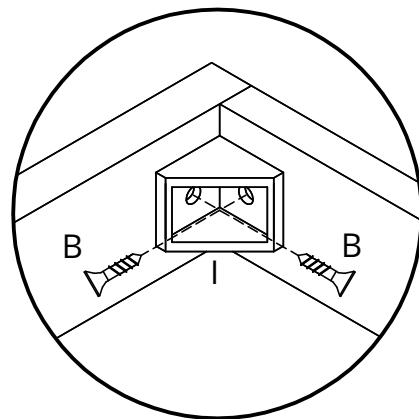
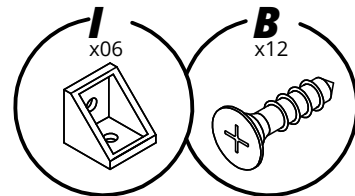
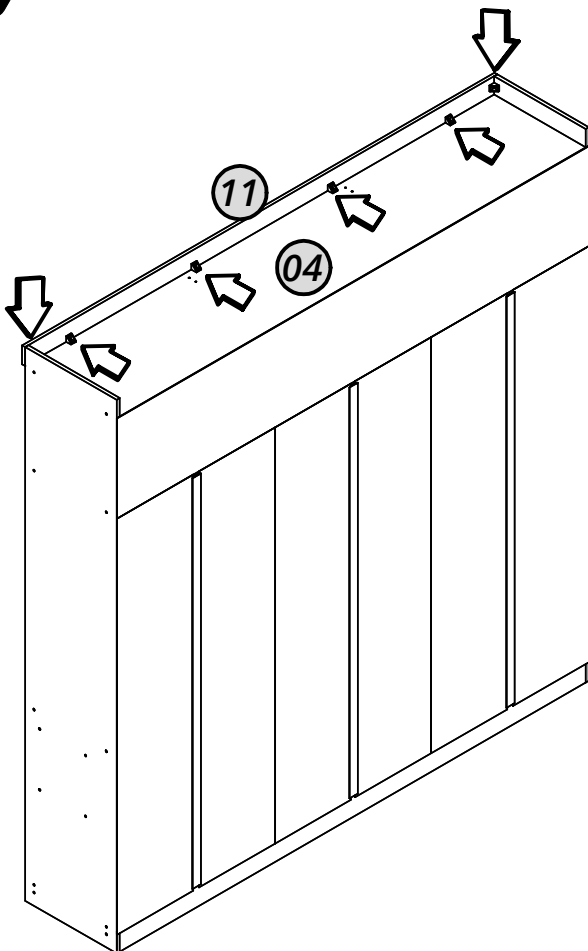

17

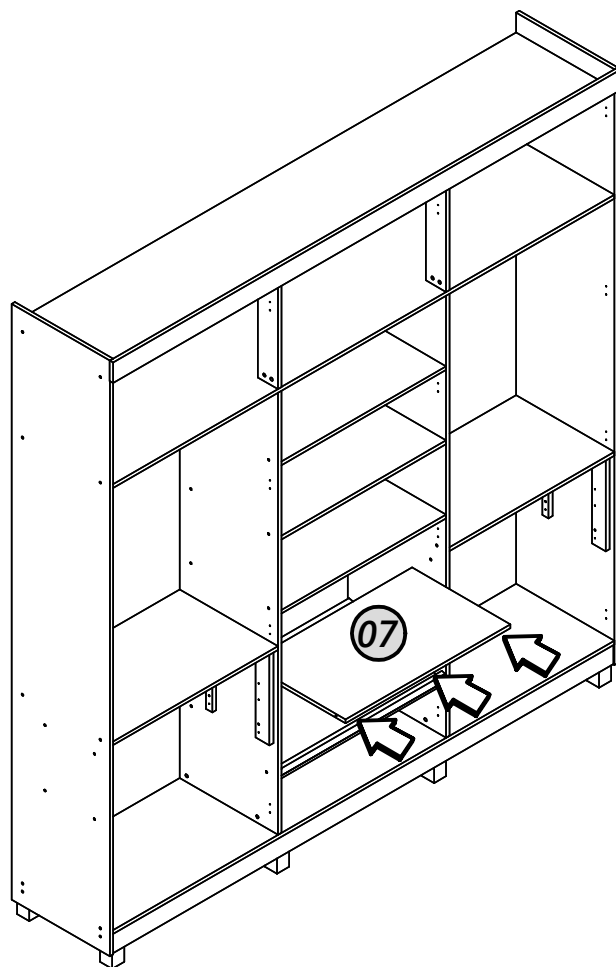

18

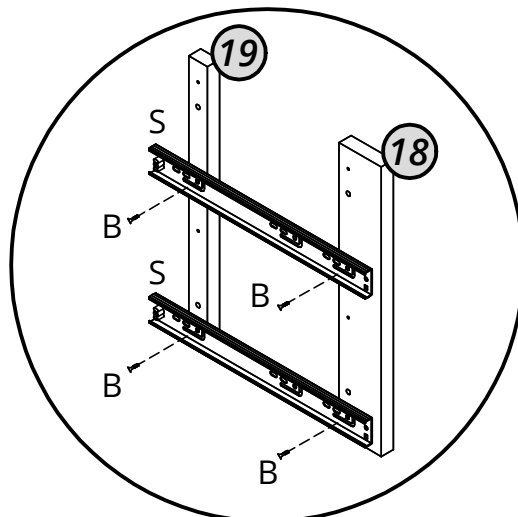
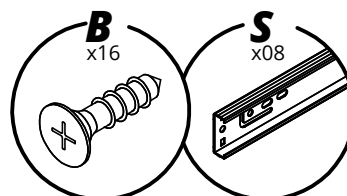
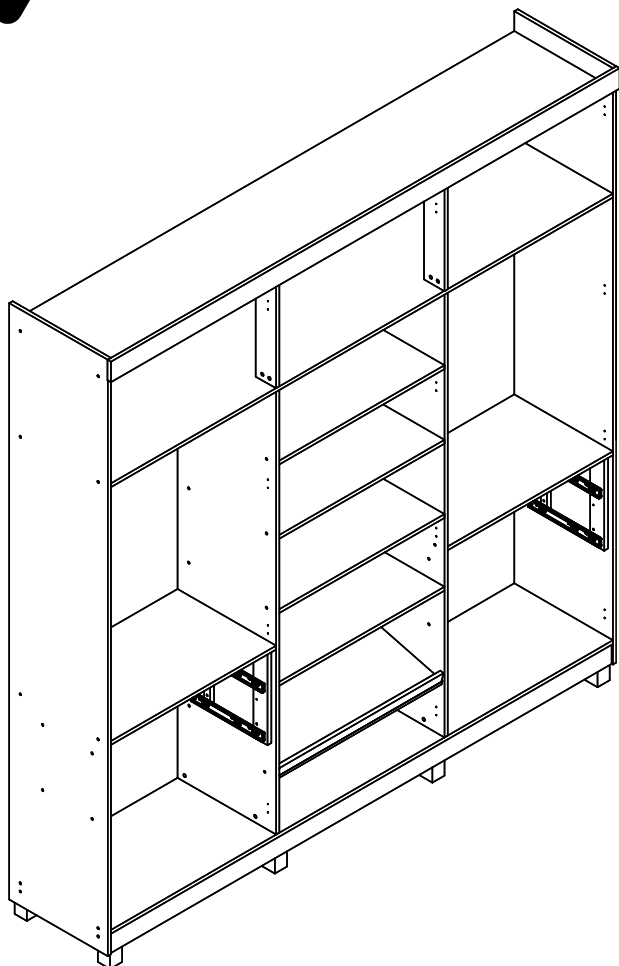

19

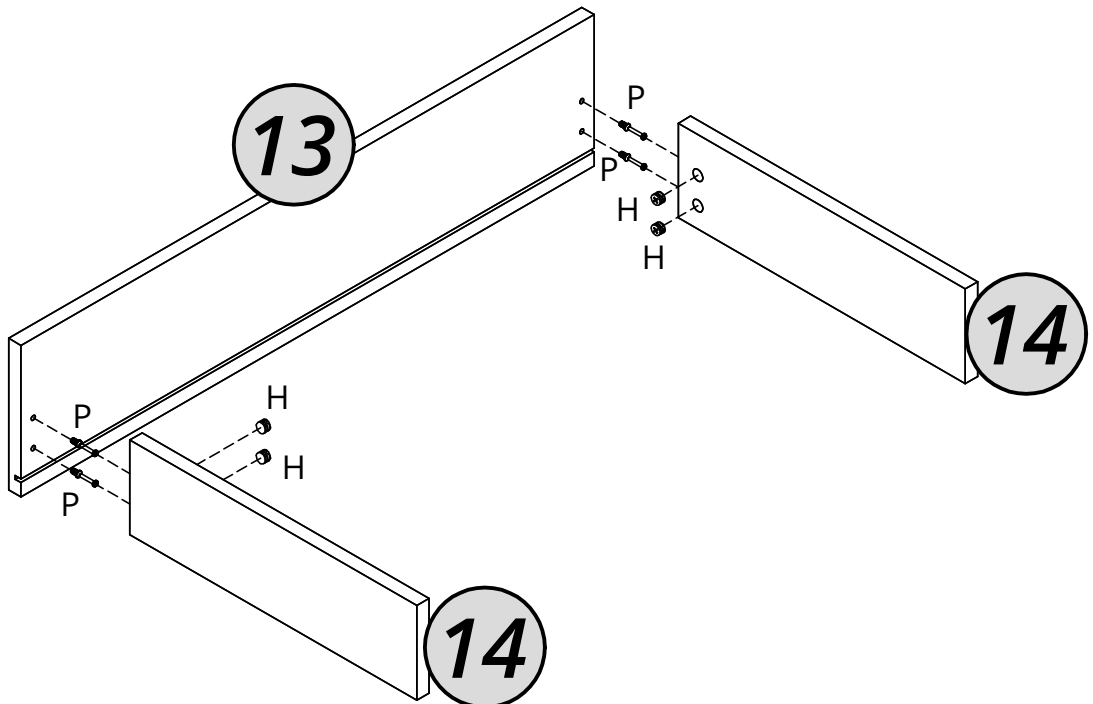
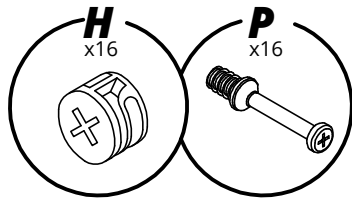

20

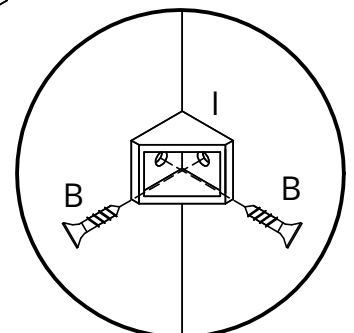
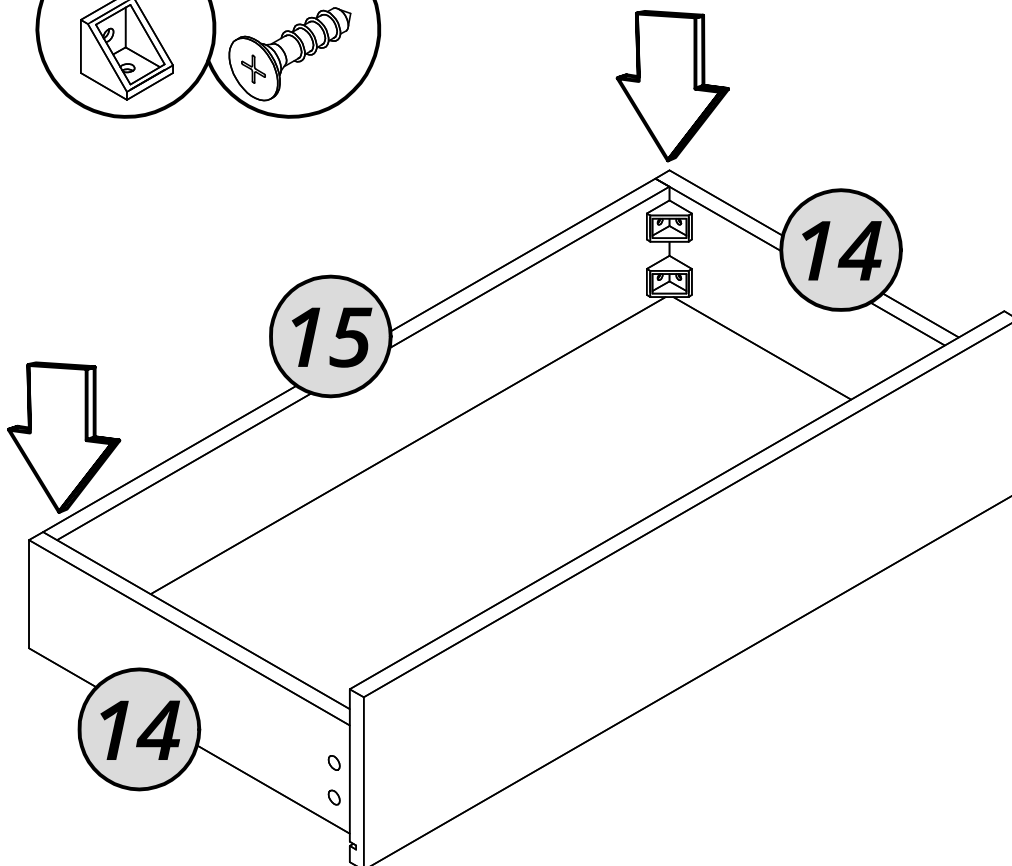
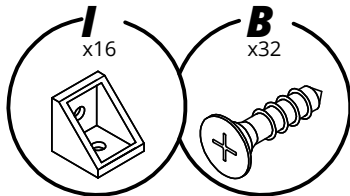

21

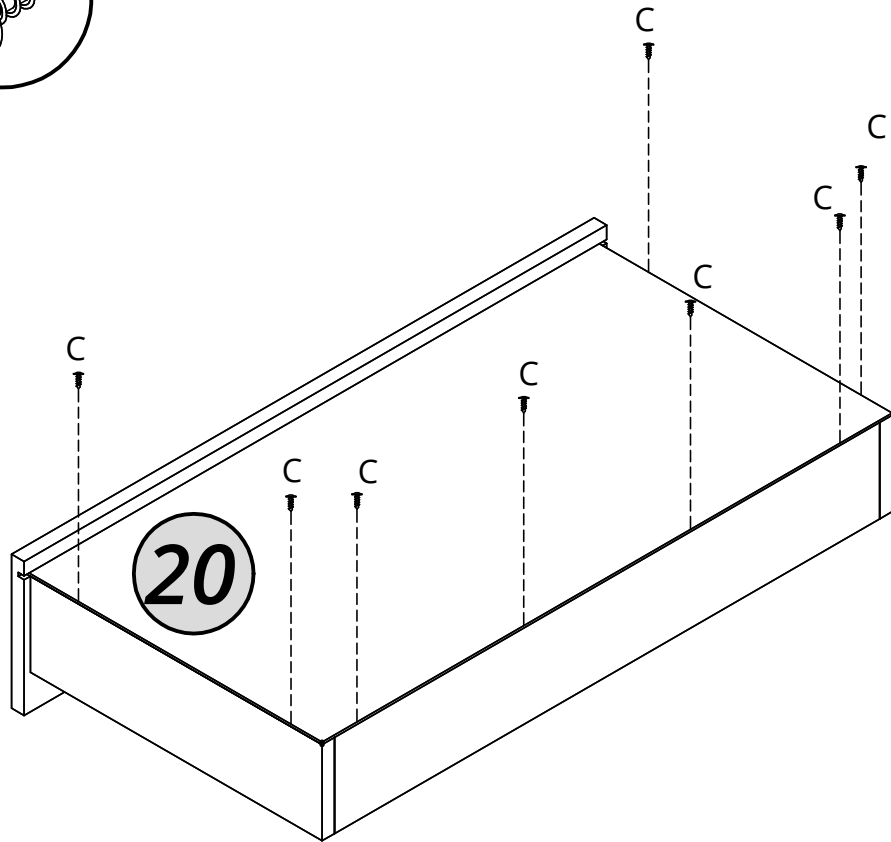
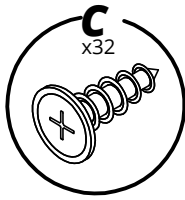

22

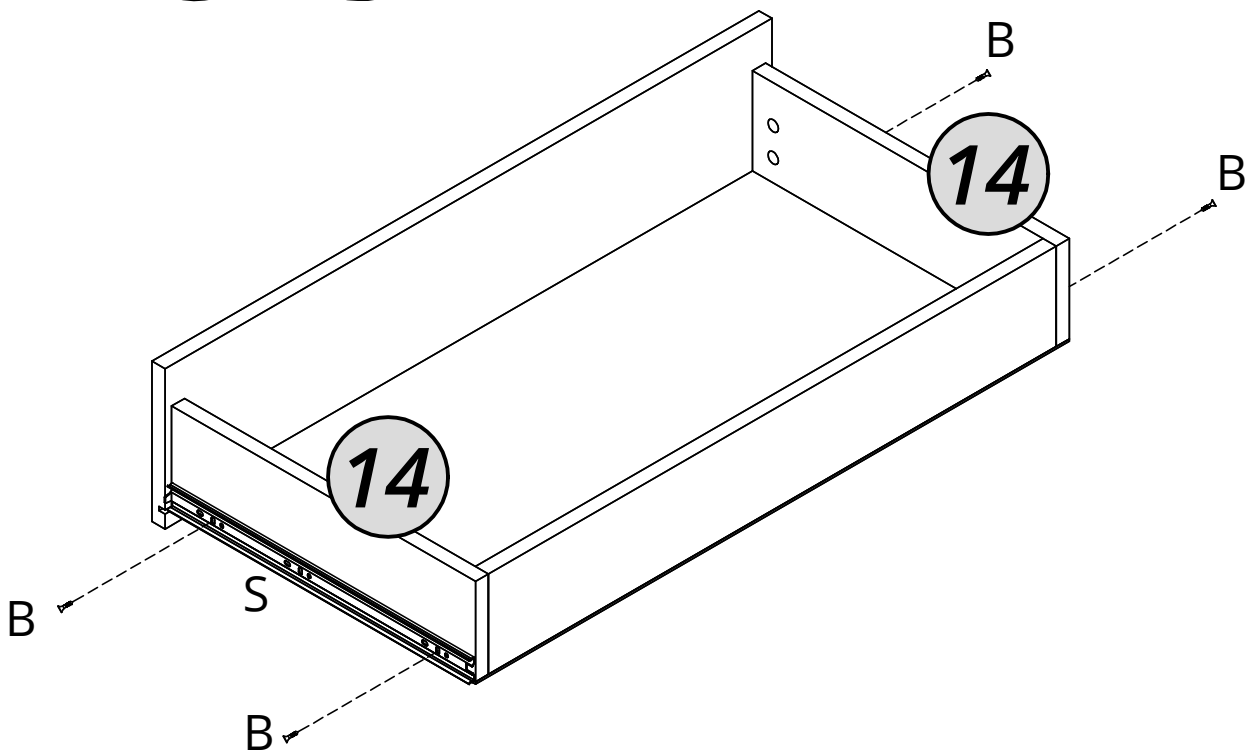
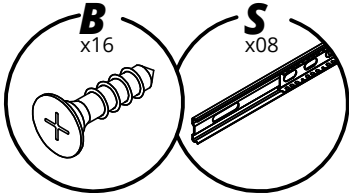

23

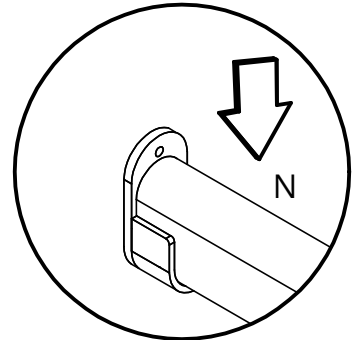
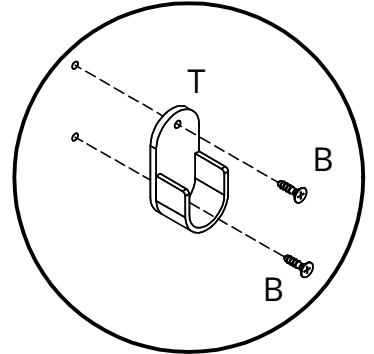
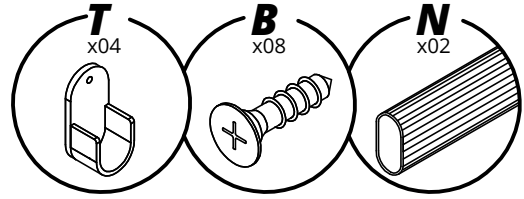
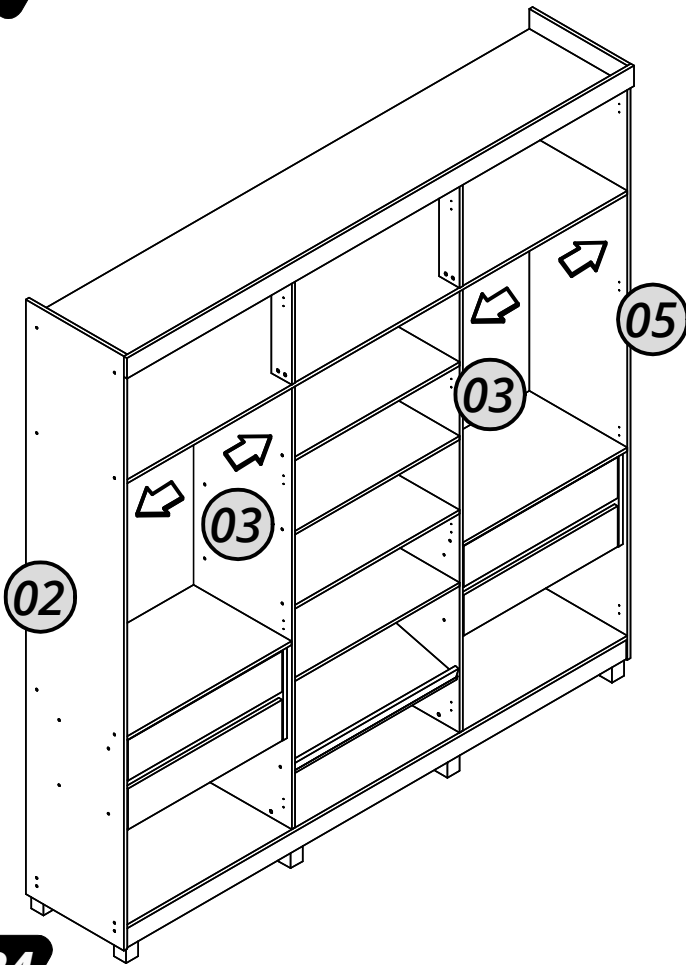

24

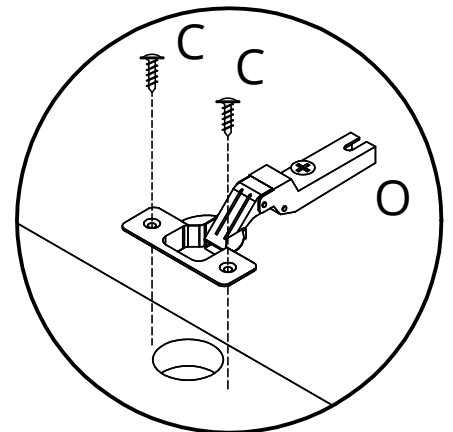
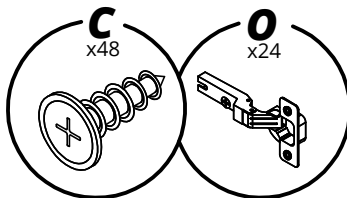
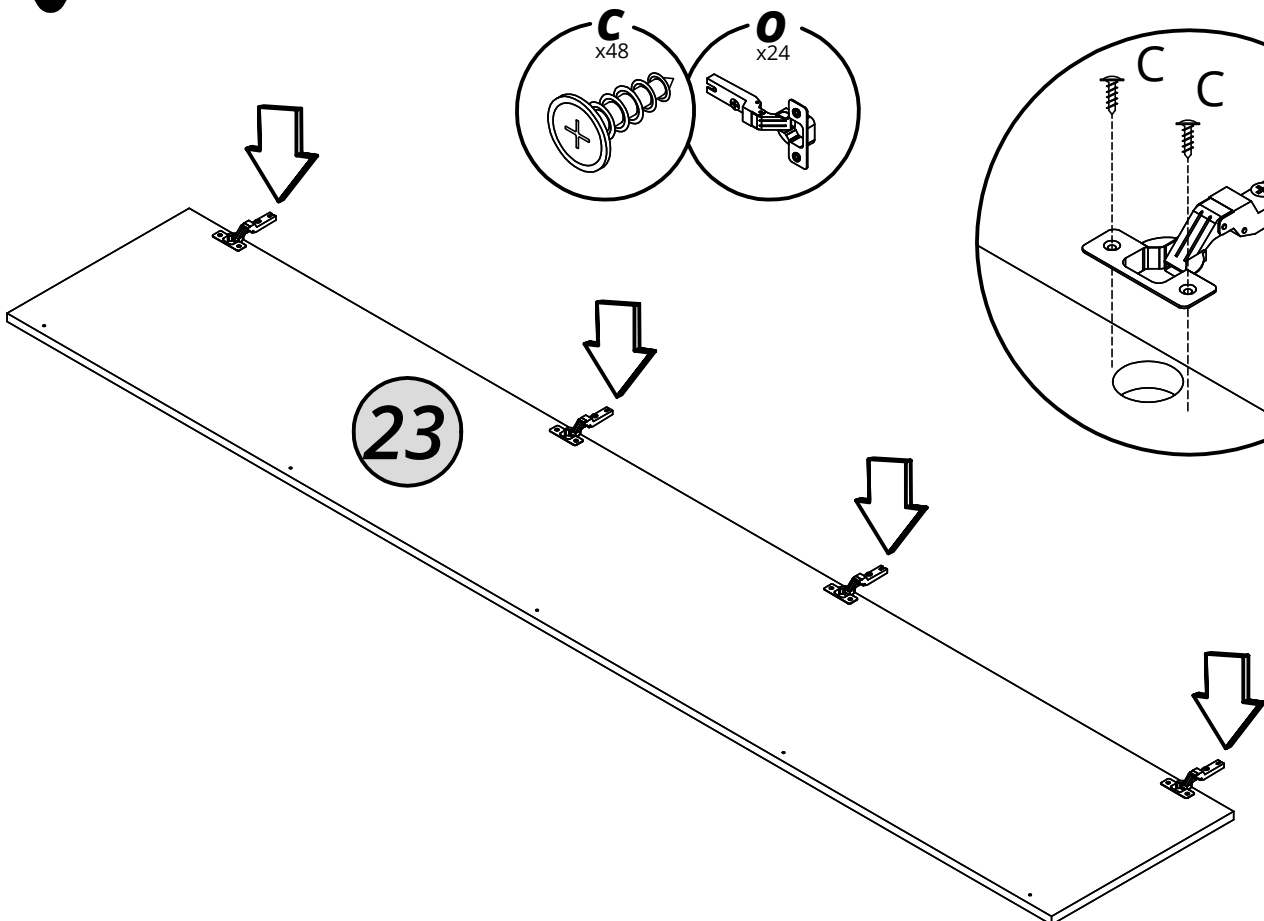

25

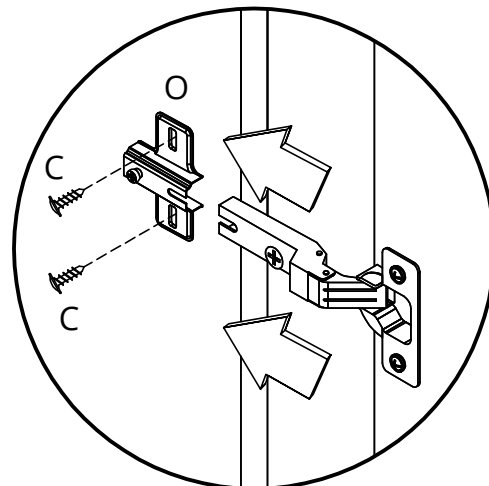
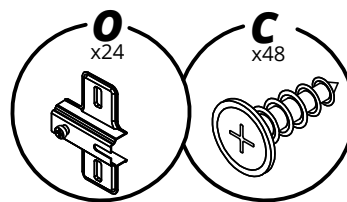
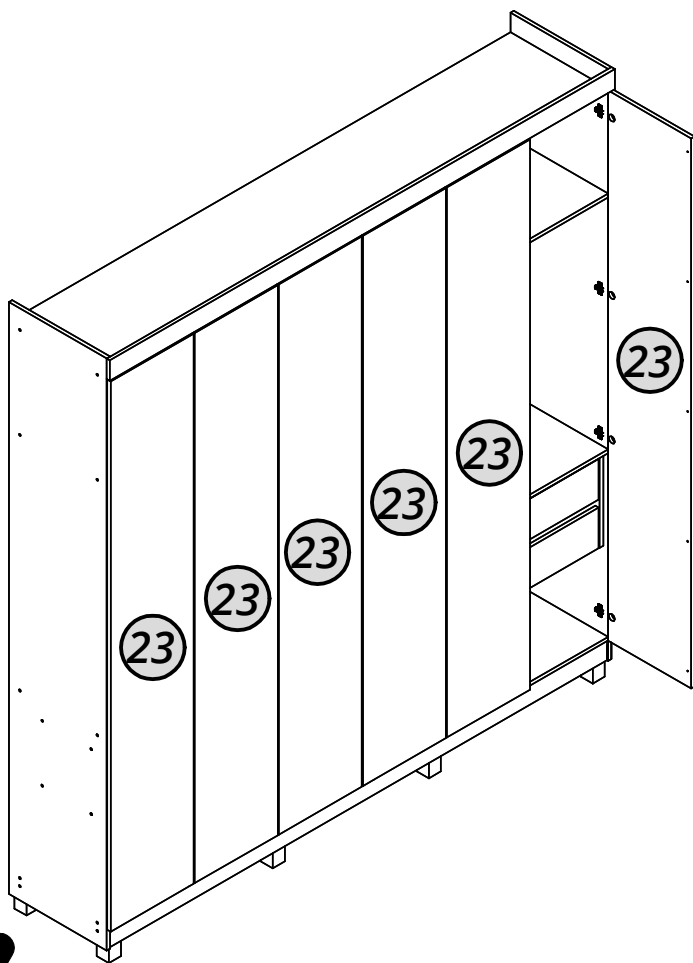

26

