

Nº	Cód.	Peças	Piezas	Parts	Medida / Size	Qtd.	Vol.
01	07197	Base / Tampo	Base / Cubierta	Base / Top	2190x535x12	02	02
02	07198	Lateral esquerda	Lateral izquierda	Left side	2190x535x12	01	02
03	07200	Divisoria esquerda	División izquierda	Left division	1970x535x12	01	03
04	07201	Divisoria direita	División derecha	Right division	1970x535x12	01	03
05	07199	Lateral direita	Lateral derecha	Right side	2190x535x12	01	02
06	07225	Porta espelho	Puerta espejo	Mirror door	1986x607x12	01	01
07	07202	Rodapé frontal	Rodapé frontal	Lower front crossbar	2190x100x12	01	02
08	07203	Rodapé traseiro	Rodapé trasero	Lower rear crossbar	2190x100x12	01	02
09	07204	Trava do rodapé	Traba del rodapé	Smaller crossbar	505x100x12	04	02
10	07205	Prateleira do maleiro	Estante	Shelf	783x535x12	02	01
11	07206	Prateleira fixa sapateira	Estante fija zapatera	Shelf fixed shoe storage	600x535x12	02	03
12	07207	Prateleira movel sapateira	Estante movible zapatera	Shelf adjustable shoe storage	600x445x12	03	03
13	07208	Prateleira	Estante	Shelf	783x445x12	02	03
14	07209	Frente de gaveta	Frente del cajón	Front of drawer	736x160x12	03	03
15	07210	Lateral de gaveta	Lateral del cajón	Side panel of the drawer	350x100x12	06	03
16	07211	Contra fundo	Trasero del cajón	Rear panel of the drawer	698x100x12	03	03
17	07213	Moldura superior	Cubierta superior	Upper frame	2214x100x15	01	02
18	07214	Portas (VERSÃO DIAMANTE)	Puertas	Doors	1988x395x15	04	01
18	07650	Portas (VERSÃO DIAMANTE PLUS)	Puertas	Doors	1988x395x15	04	01
19	*	Puxador	Tirador	Handle	670x20x15	04	03
20	07226	Puxador porta espelho	Tirador puerta espejo	Handle mirror door	1982x28x18	01	03
21	07217	Distanciador frontal	Espaciador frontal	Front spacer	566x63x18	02	03
22	07218	Distanciador traseiro	Espaciador trasero	Rear spacer	566x28x18	02	03
23	07219	Fundo traseiro menor	Fondo trasero menor	Bottom rear smaller	1995x616x2,5	01	01
24	07220	Fundo traseiro maior	Fondo trasero mayor	Bottom rear bigger	1995x795x2,5	02	01
25	07221	Fundo de gaveta	Fondo del cajon	Bottom of the drawer	722x355x2,5	03	02
26	30014154	Tubo cabideiro	Tubo	Hanger bar	770mm	02	03
27	30017621	Espelho (Kit)	Espejo	Mirror	661x587x3	03	04
28	30017572	Kit Pé	Kit pie	Foot kit	50x50x115	01	03

Recorte aqui e guarde seu certificado de garantia!

# Certificado de garantia

A Gelius Indústria de Móveis confia na qualidade de seus produtos e por isso o garante pelo prazo de 90 dias para defeitos de fabricação em condições normais de uso.

Resultarão nula a garantia e sem efeito a cobertura, se o produto, (incluindo vidros e ou espelhos que o compõe):

- sofrer dano provocado por acidente, agente da natureza.
- uso indevido ou maus tratos como arrastar, subir em cima, colocar produtos com excesso de peso).
- não utilizado para os fins a que se destina.
- conter manchas provocadas por uso de produtos químicos em sua limpeza.
- excesso de umidade ou água.

Ao detectar qualquer defeito em seu móvel, entre em contato com a loja onde foi efetuada a compra. A comprovação de que o móvel a ser consertado ou substituído encontra-se dentro do prazo de garantia é de total responsabilidade do fabricante e deve ser feita mediante a apresentação desse certificado corretamente preenchido e sem rasuras ou resalvas.

Cuidados com seu móvel Gelius!

- para limpeza do seu móvel, utilize apenas pano macio e seco.
- jamais limpe-o com palha de aço, álcool ou qualquer outro produto químico ou abrasivos, óleos de peroba ou produtos do gênero.
- evite deixá-lo sob raios solares ou chuva.
- ao transportar o seu móvel Gelius, prenda-o firmemente para que não ocorra quedas indesejáveis.

Seguindo corretamente as informações acima, você conservará por muito mais tempo o seu móvel Gelius!

GARANTIA DO CLIENTE:

Cliente: \_\_\_\_\_

Rua: \_\_\_\_\_ Nº: \_\_\_\_\_ Bairro: \_\_\_\_\_

Cidade: \_\_\_\_\_ UF: \_\_\_\_\_ Loja onde comprou: \_\_\_\_\_

Data da compra: \_\_\_\_/\_\_\_\_/\_\_\_\_ Nota Fiscal: \_\_\_\_\_

Data da reclamação na loja: \_\_\_\_/\_\_\_\_/\_\_\_\_

Defeito constante: \_\_\_\_\_

## Recomendações | Recomendaciones | Recommendations

**Atenção**  
Atención  
Attention

**Este produto deve ser montado por um profissional.**

Este producto debe ser ensamblado por un profesional.

This product must be assembled by a professional.

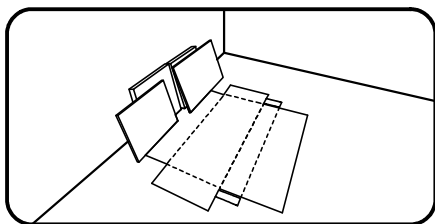

**Antes de começar a montagem prepare o ambiente, deixando-o completamente limpo e com bom espaço para iniciar o trabalho. Utilize o papelão da própria embalagem para separar e apoiar as peças retiradas da caixa.**

Antes de comenzar el montaje preparar el ambiente, dejándolo completamente limpio y con buen espacio para comenzar el trabajo. Utilice el cartón de la embalaje para separar y apoyar las piezas desmontadas de las cajas.

Prepare the room before starting the assembly, leaving it completely clean and the area in good condition to start the work. Use the cardboard of the packaging to separate and support the parts removed from the boxes.

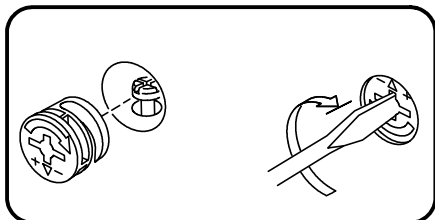

**Como usar o acessório Pino e Tambor Minifix (quando utilizado no produto).**

Como usar el herraje Pino y Tambor Minifix (cuando se usa en el producto).

How to use the Minifix Set (when used in the product).

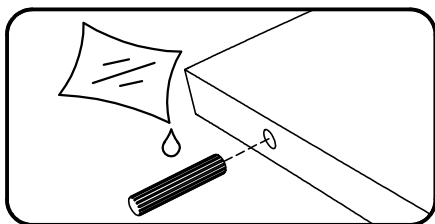

**Aplicar cola nas cavilhas de madeira (quando utilizado no produto).**

Aplicar pegamento a las clavijas de madera (cuando se usa en el producto).

Apply glues to the wooden dowels (when used in the product).

Ferramentas recomendadas para montagem | Herramientas de montaje recomendadas | Recommended tools

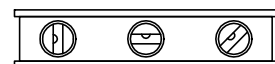
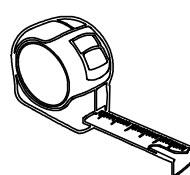
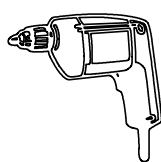
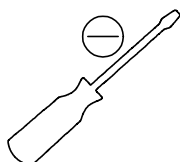
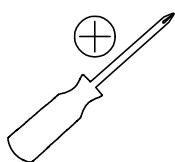

## Acessórios e ferragens | Herrajes | Hardware

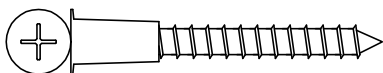

A—cód. 30008477 032 un.

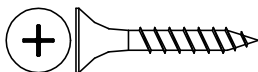

B—cód. 30010241 018 un.



C—cód. 30000711 272 un.



D—cód. 30014008 028 un.

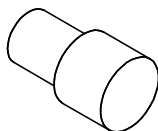

E—cód. 30000797 012 un.

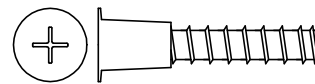

F—cód. 30000674 008 un.

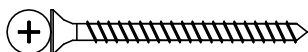

G—cód. 30001098 016 un.

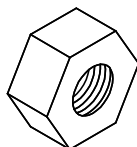

H—cód. 30014009 028 un.

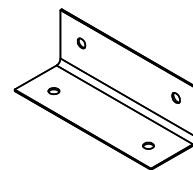

I—cód. 30003829 018 un.

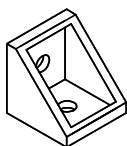

J—cód. 30009931 039 un.

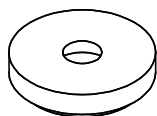

K—cód. 30000853 008 un.

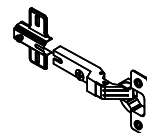

L—cód. 30017575 017 un.



M—cód. 30000783 160 un.

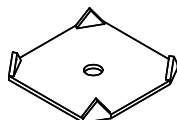

N—cód. 30001164 040 un.

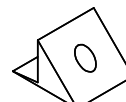

O—cód. 30001045 006 un.

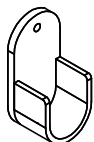

P—cód. 30001188 004 un.



Q—cód. 30000770 012 un.

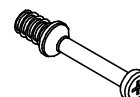

R—cód. 30006753 008 un.



S—cód. 30001073 008 un.



T—cód. 30000790 001 un.

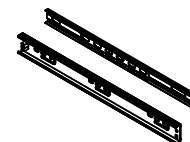

U—cód. 30013843 003 un.

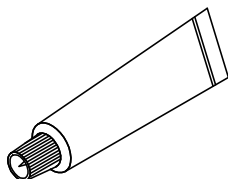

V—cód. 30017678 002 un.



W—cód. 30011233 003 un.

# ATENÇÃO

**Sr.(a) Montador (a)**

## Instruções de montagem da porta de espelho



Acesse o QR Code para  
assistir ao video de montagem.

- Primeiro, fixe o puxador na porta.

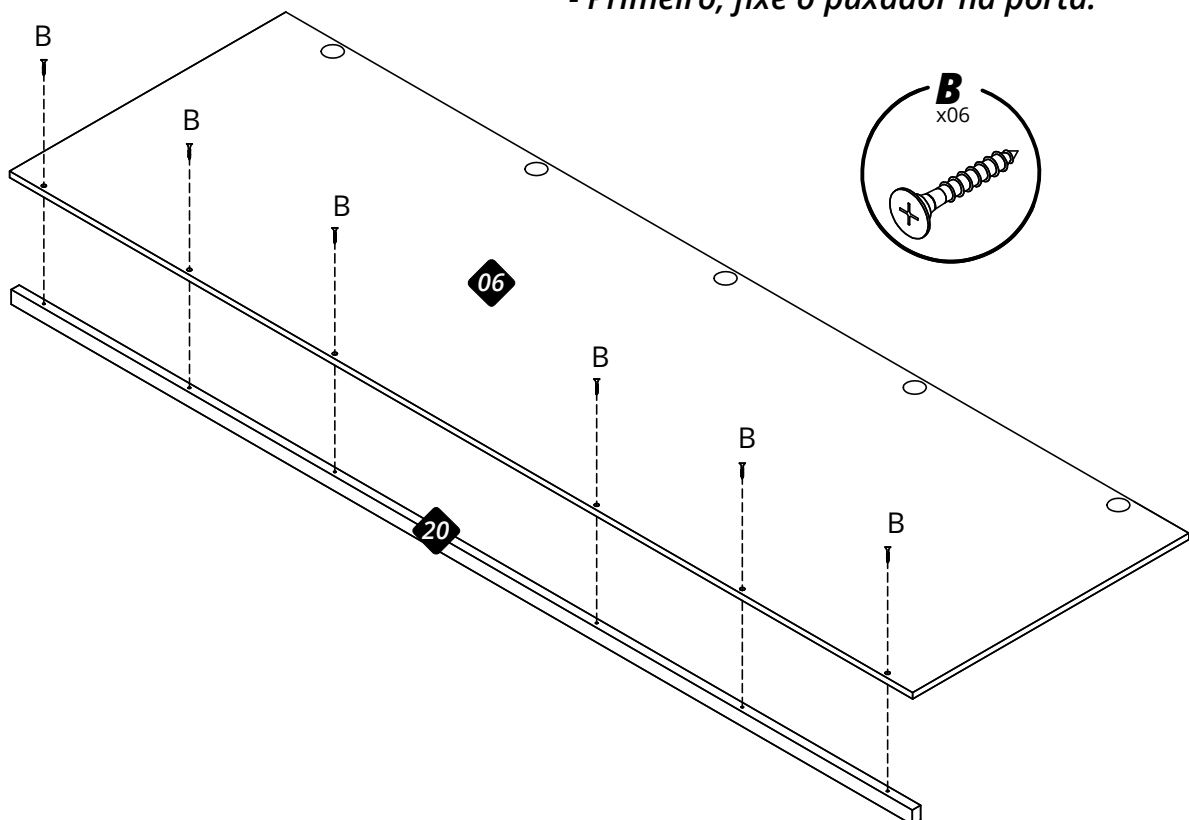

Utilize a caixa de embalagem para forrar o chão para montagem da porta.

- Com um pano seco, limpe a superfície dos espelhos e da porta.
- Retire as películas protetoras da fita dupla-face dos espelhos.
- Aplique a cola de espelho nos pontos indicados
- Importante: após aplicar, não esparramar a cola.

Tempo de secagem da cola: entre 12 e 24 horas.

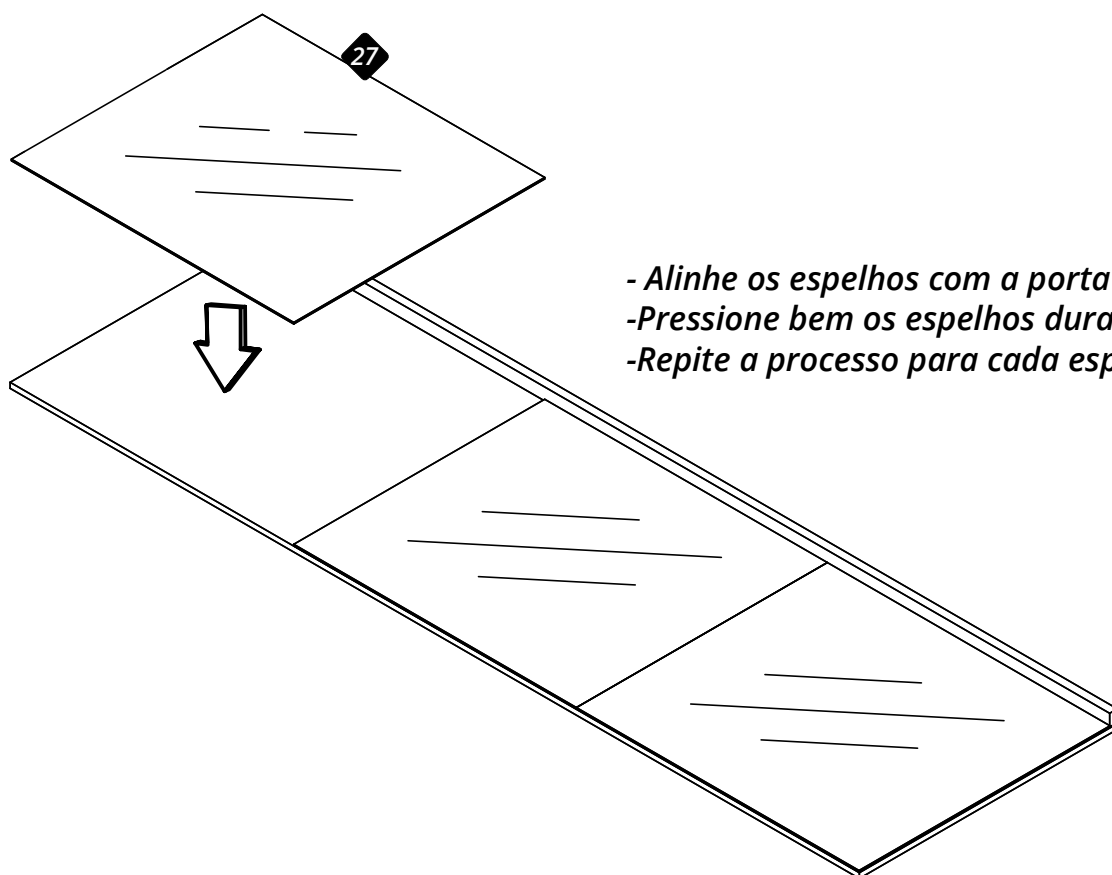
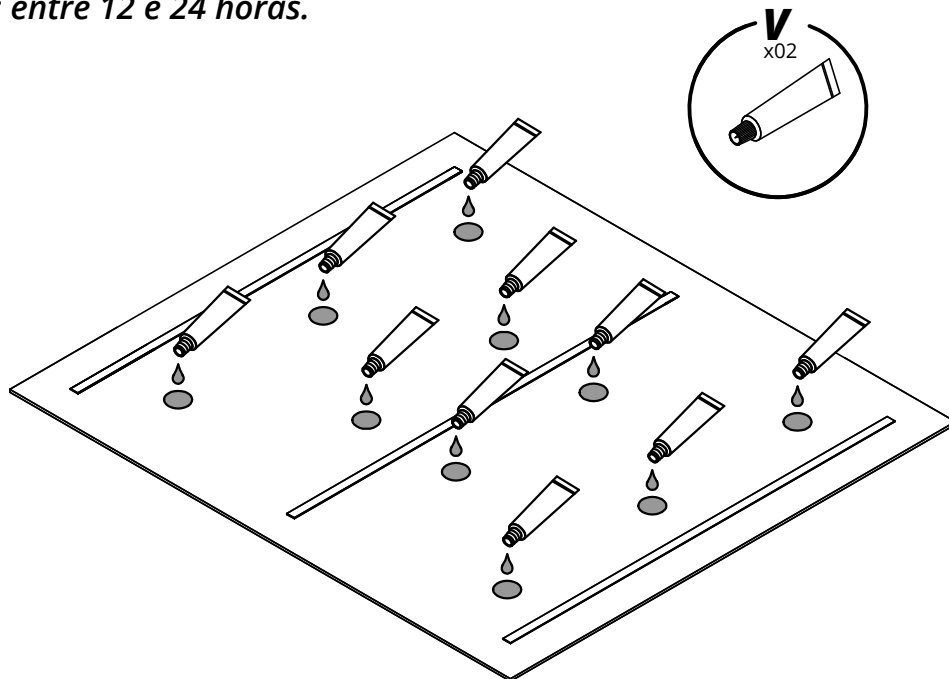

- Alinhe os espelhos com a porta
- Pressione bem os espelhos durante 10 segundos.
- Repete a processo para cada espelho.

01

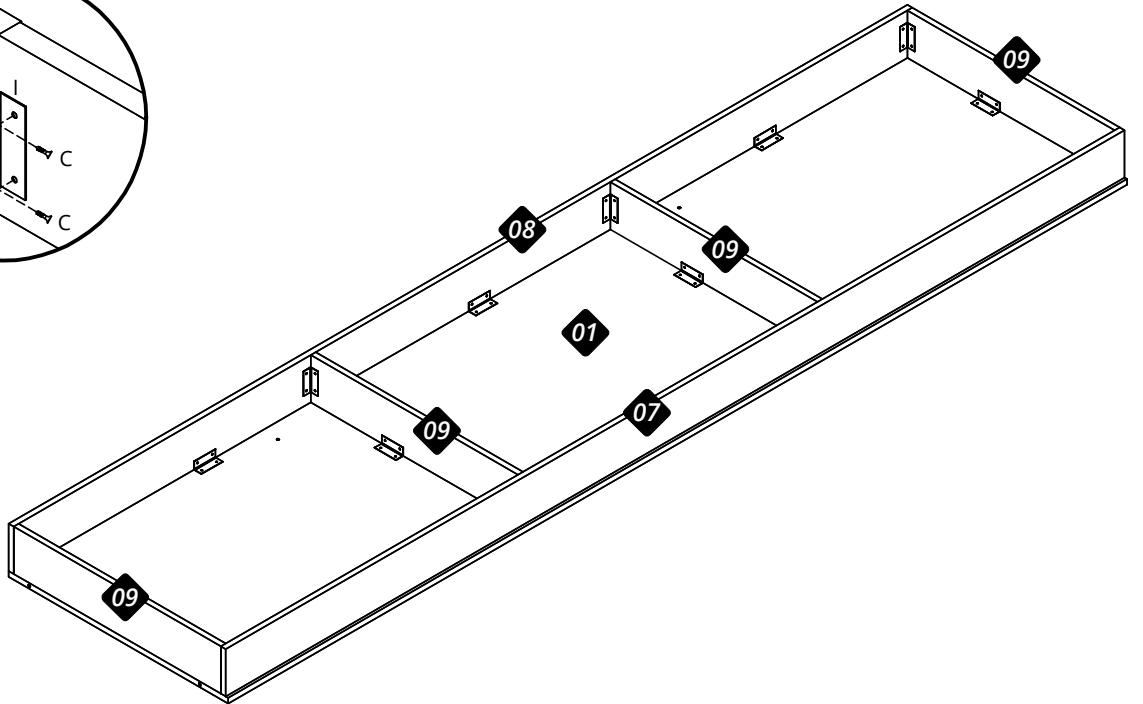
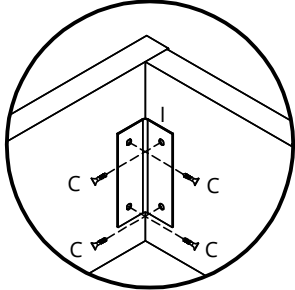
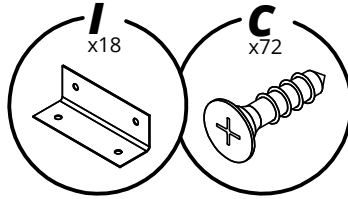

02

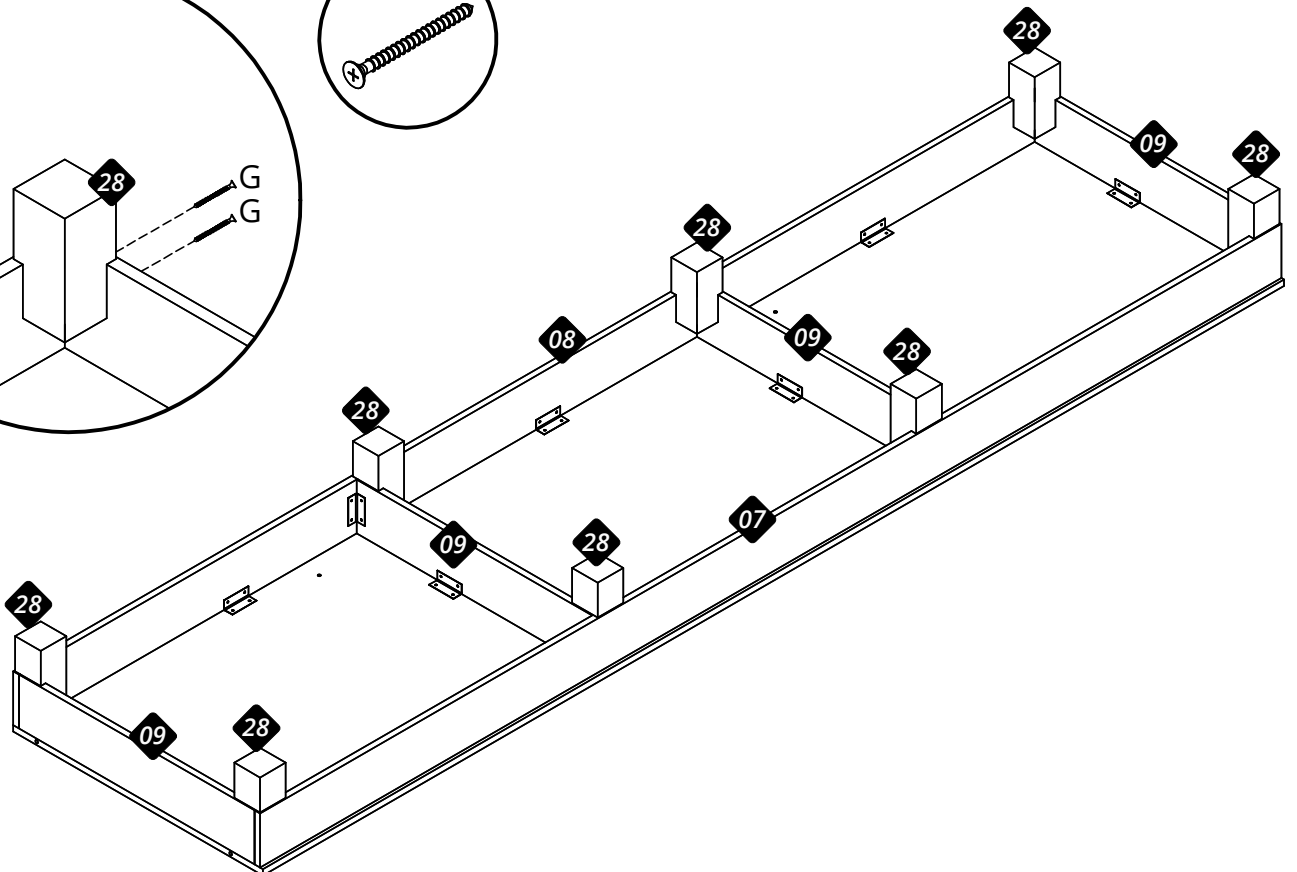
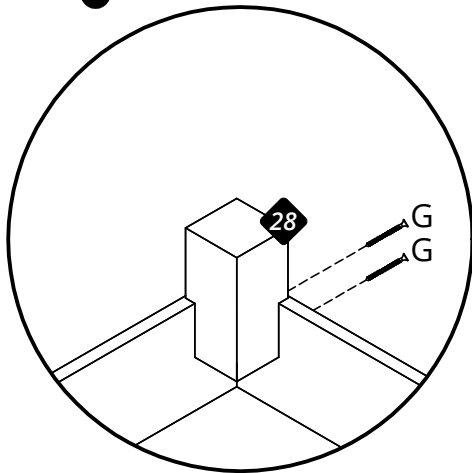
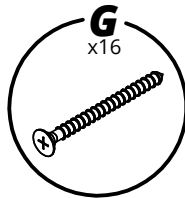

03

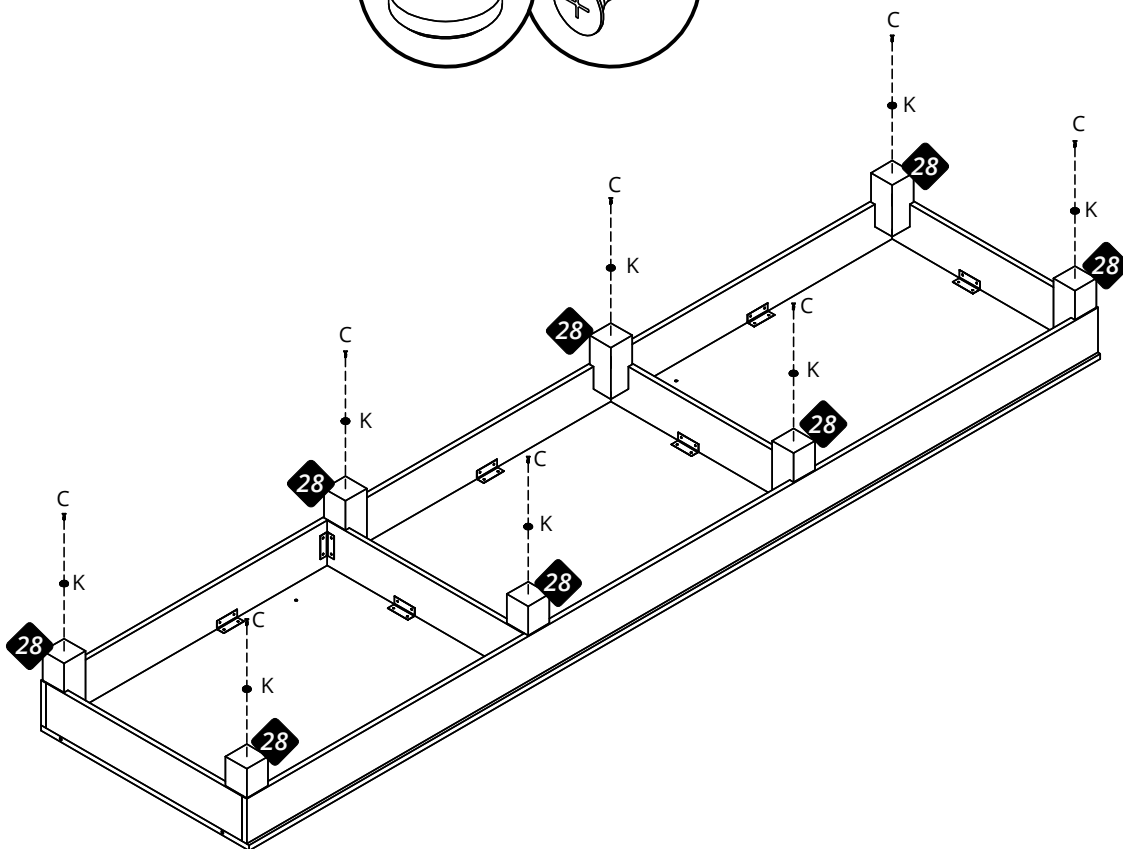
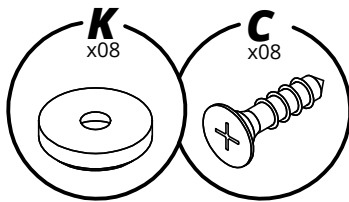

04

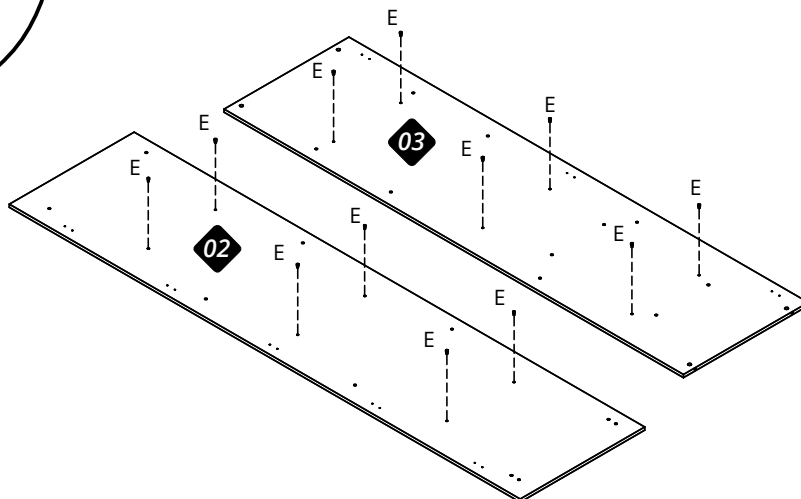
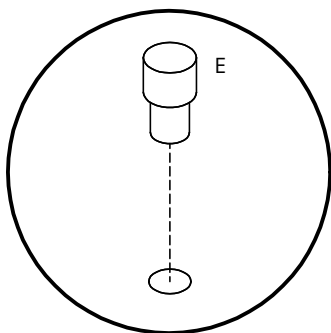
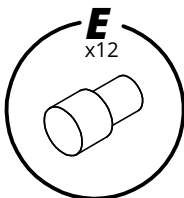

05

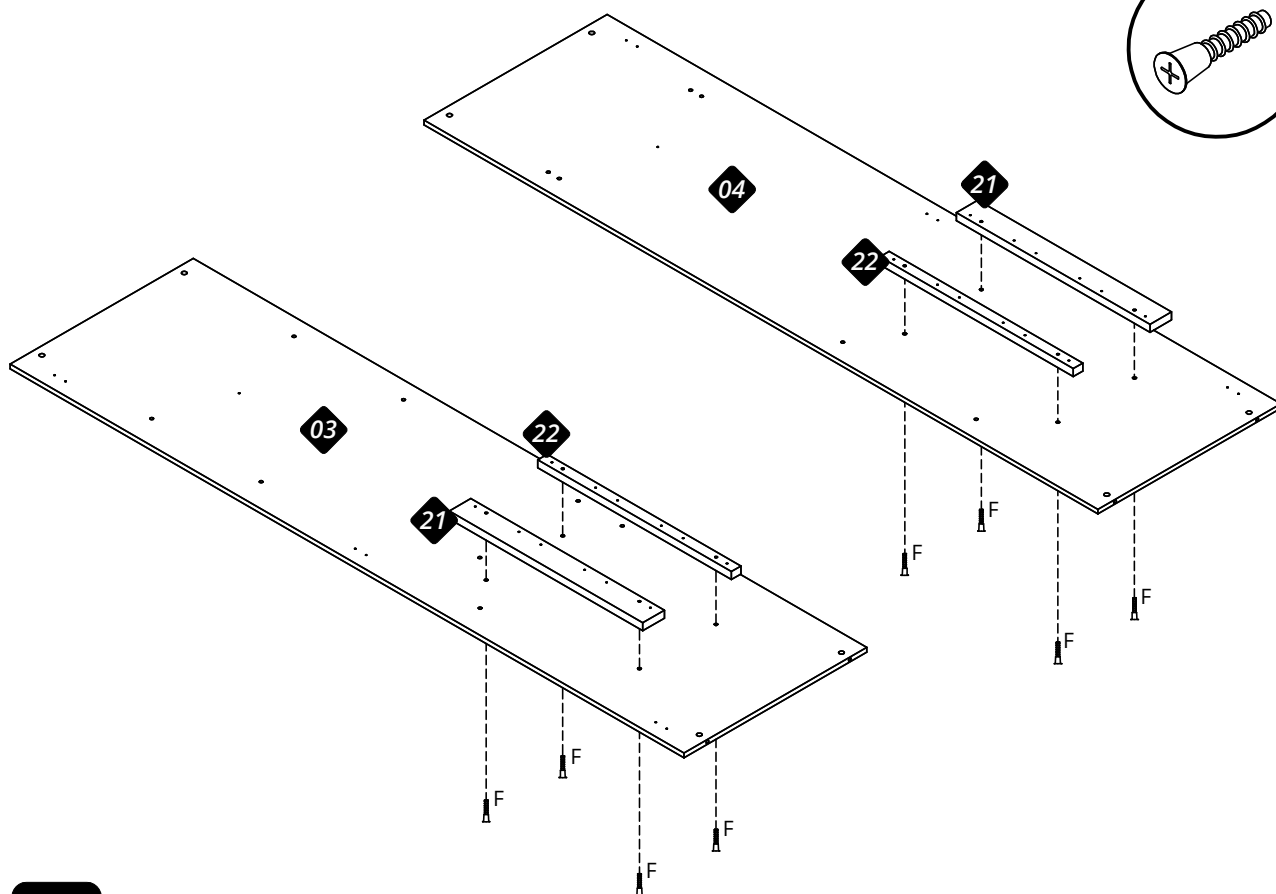
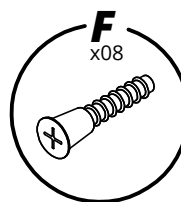

06

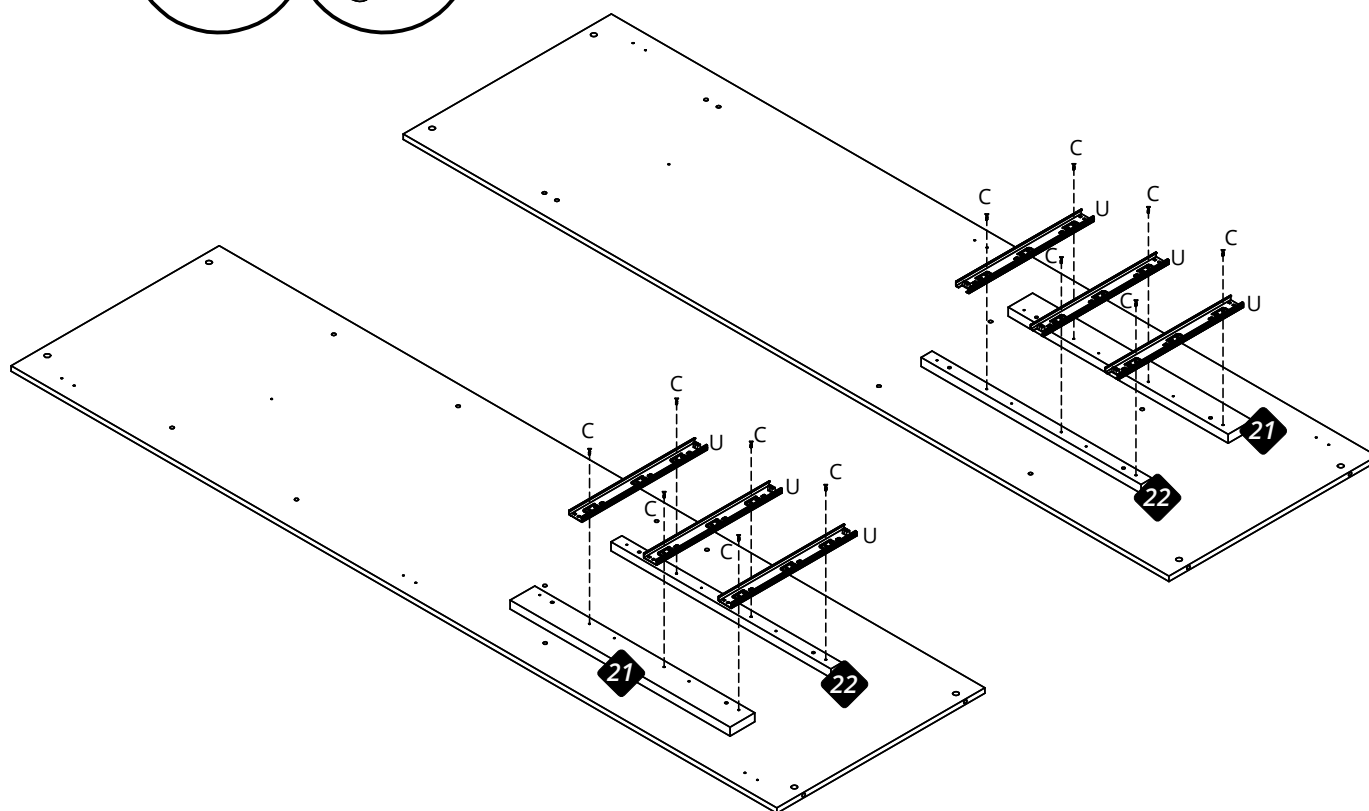
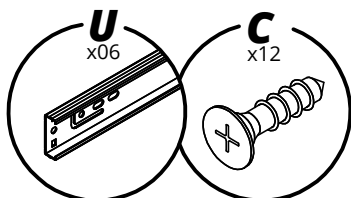



07

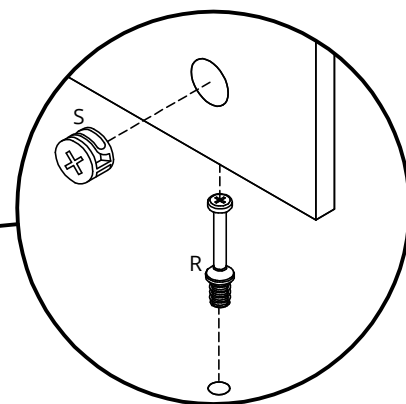
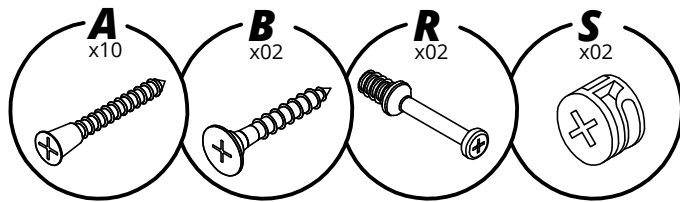
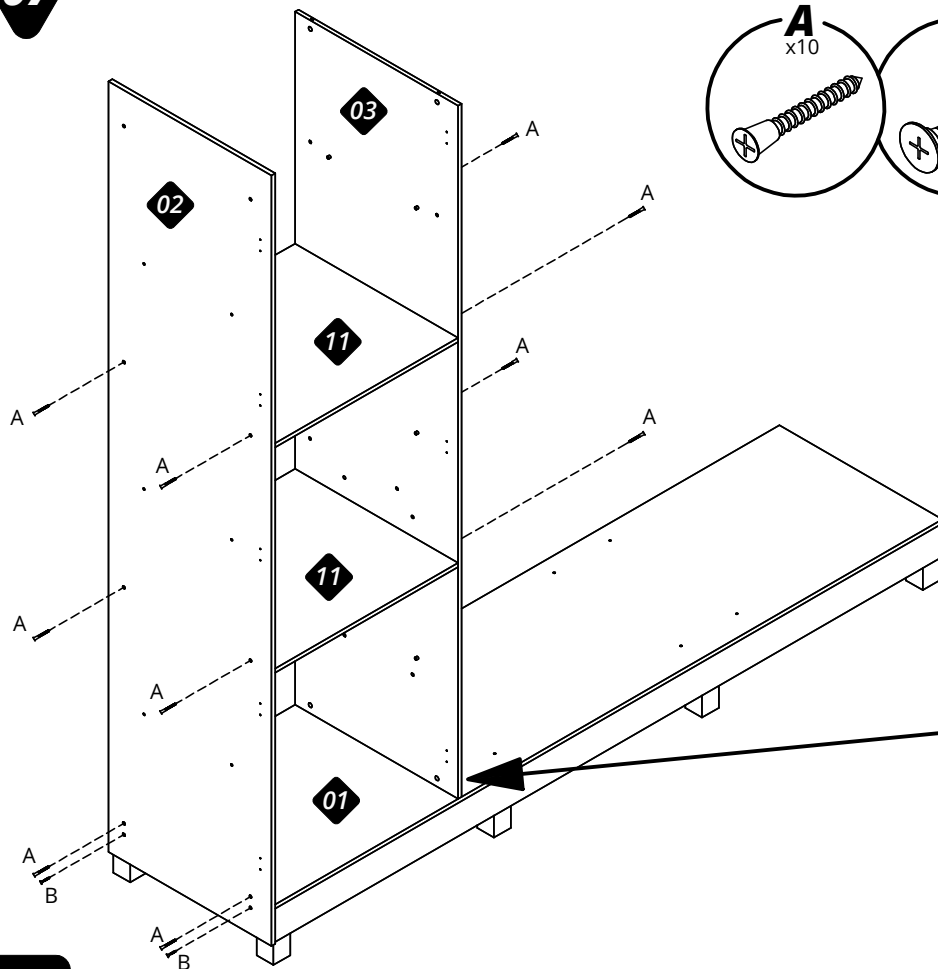

08

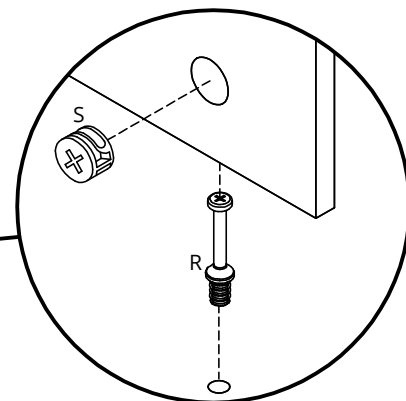
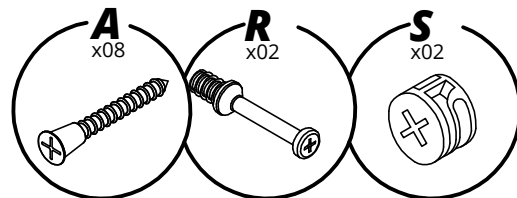
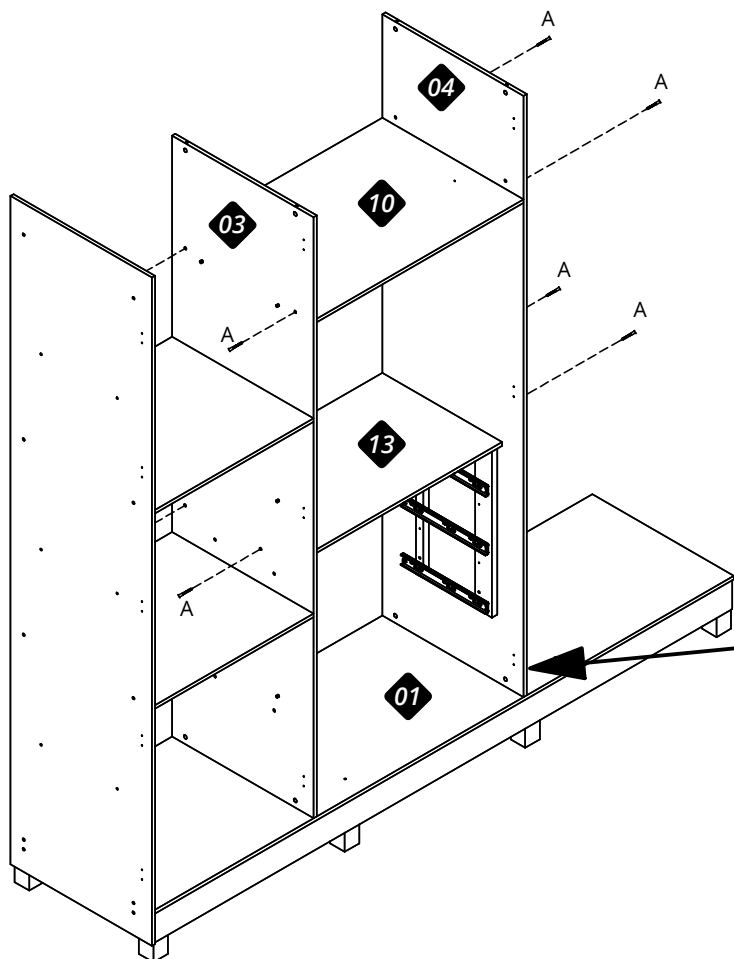

09

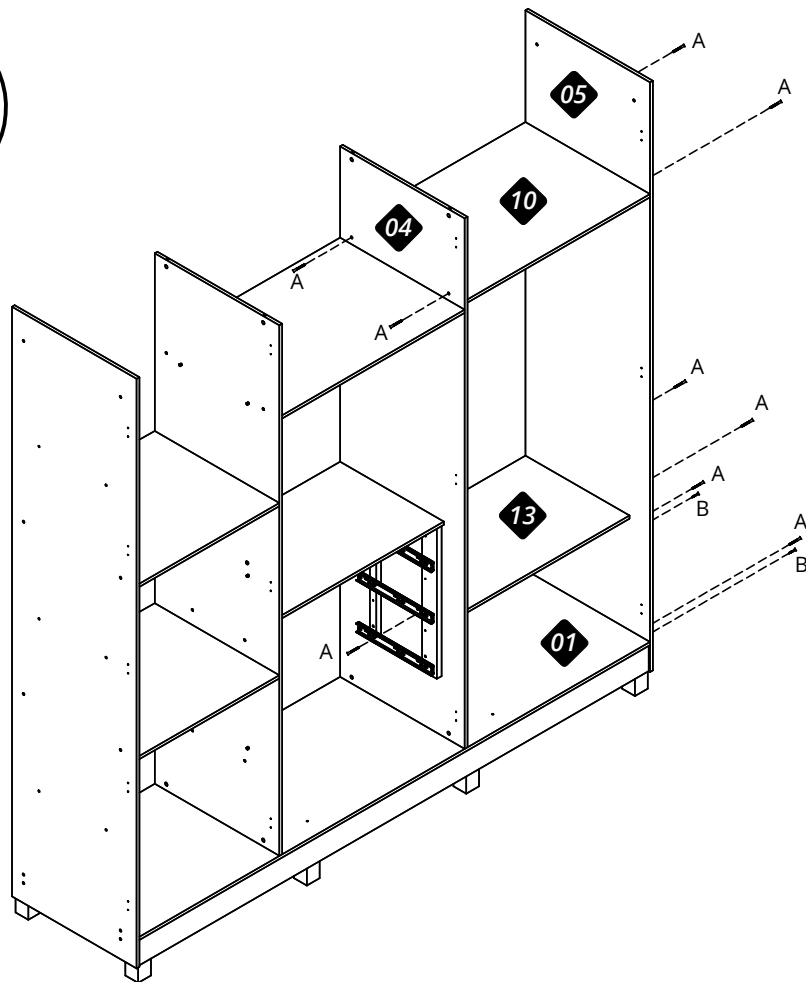
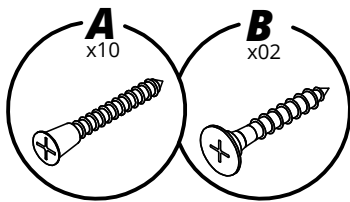

10

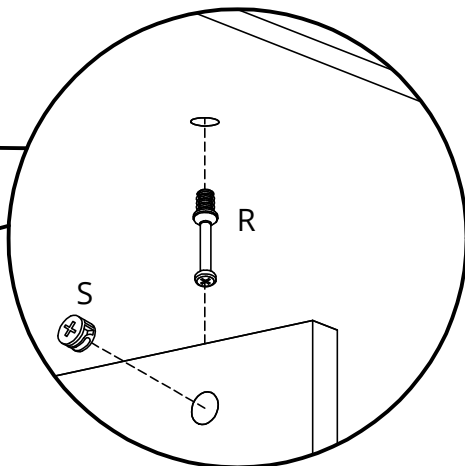
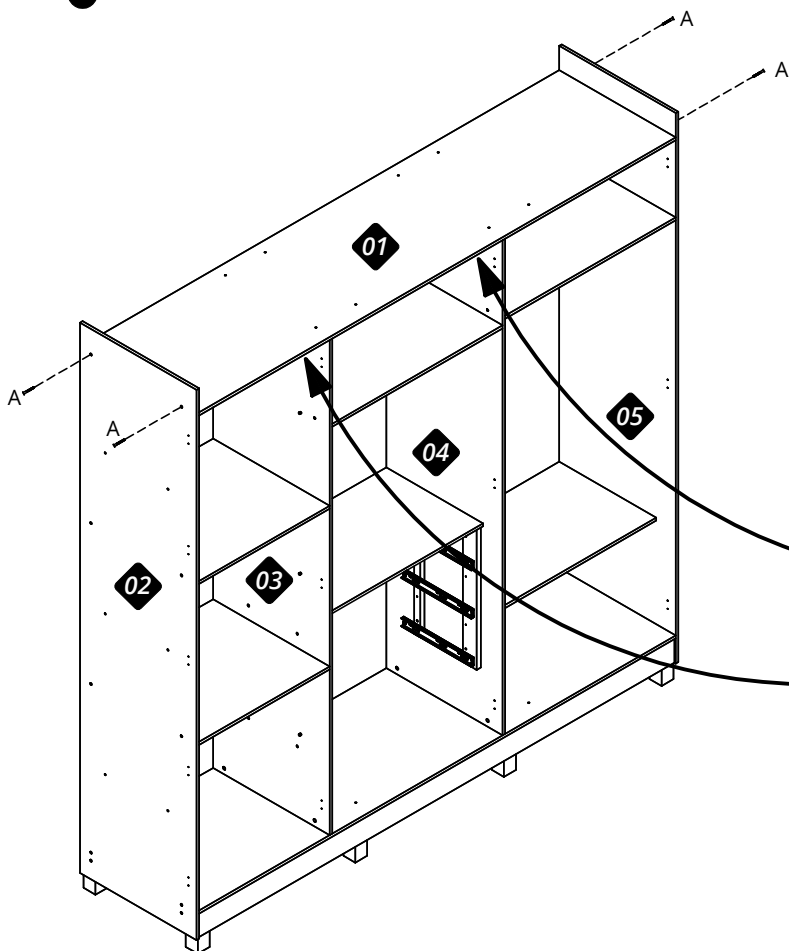
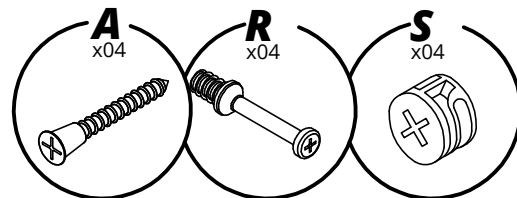

11

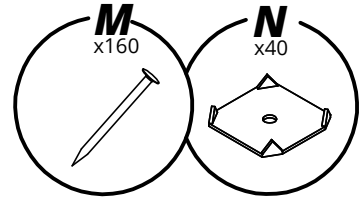
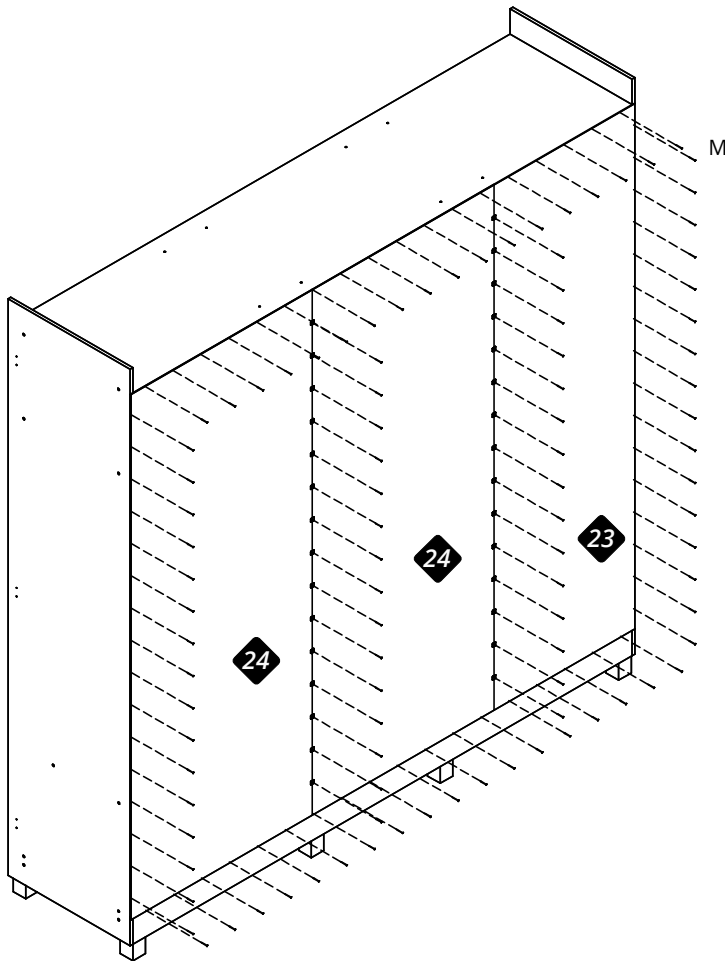

**Atenção:** Orientamos também,  
pregar os fundos nas prateleiras.

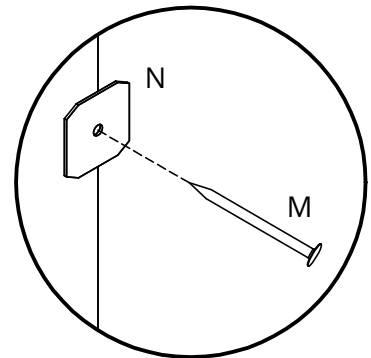

12

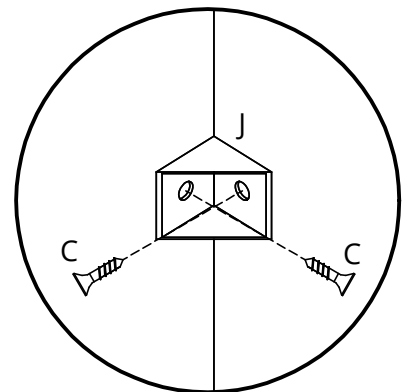
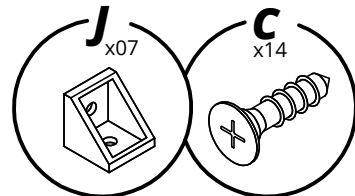
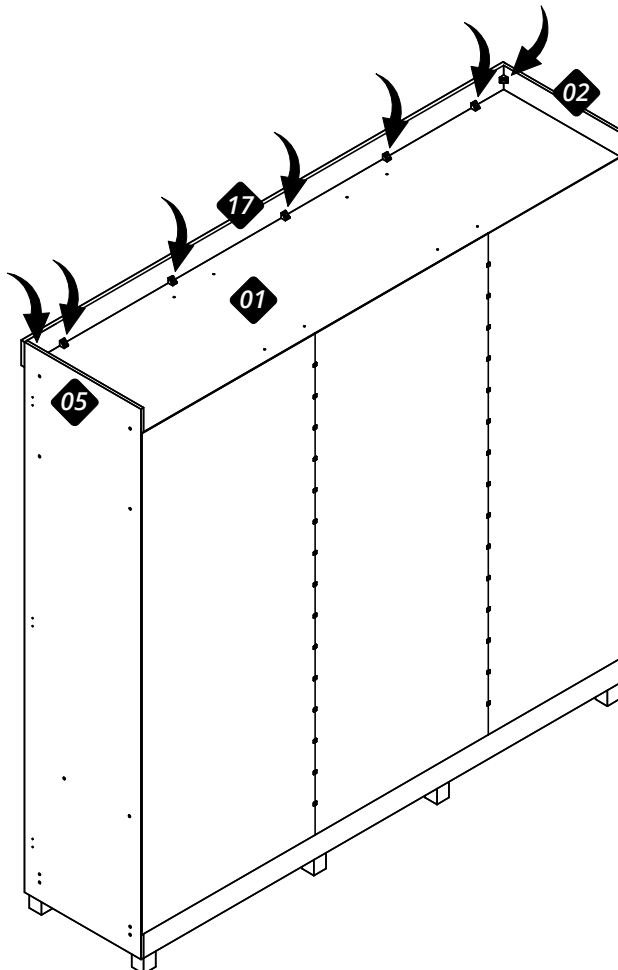

13

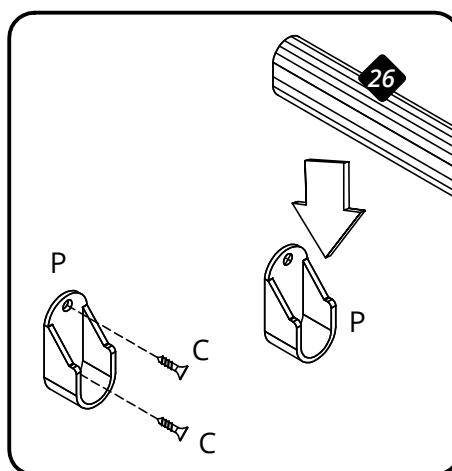
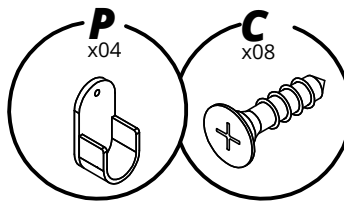
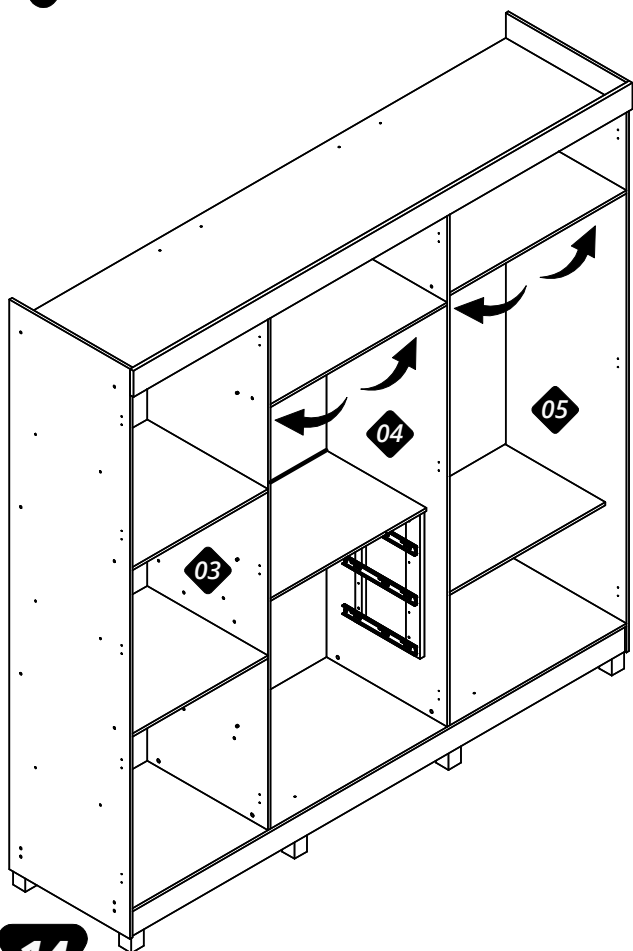

14

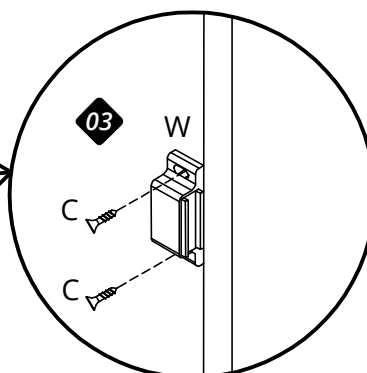
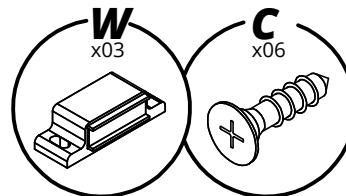
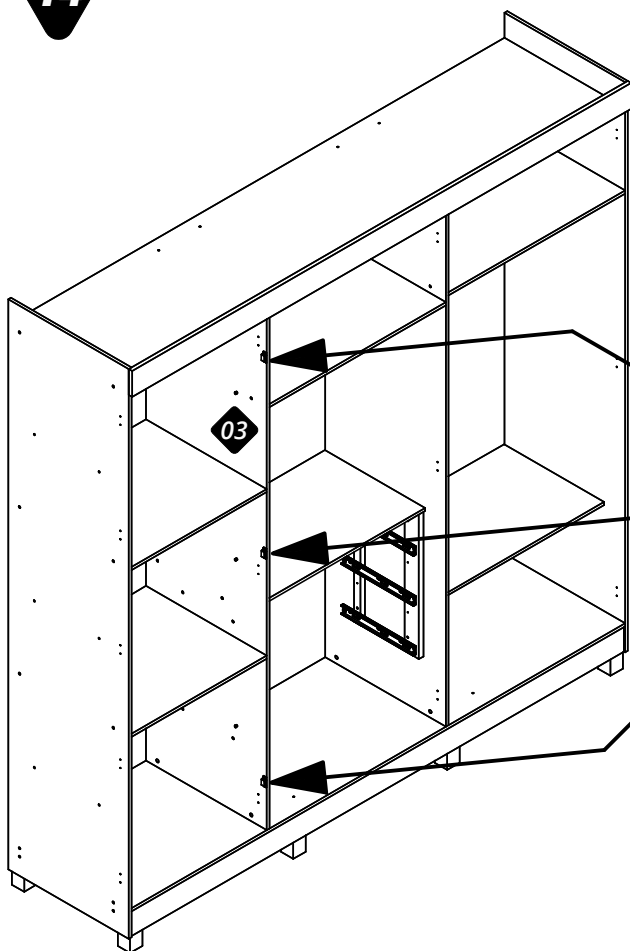

15

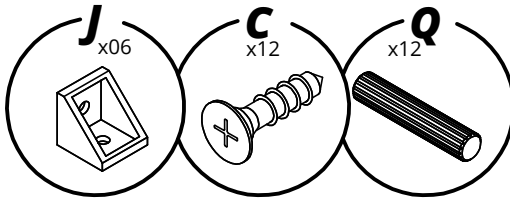

Cola

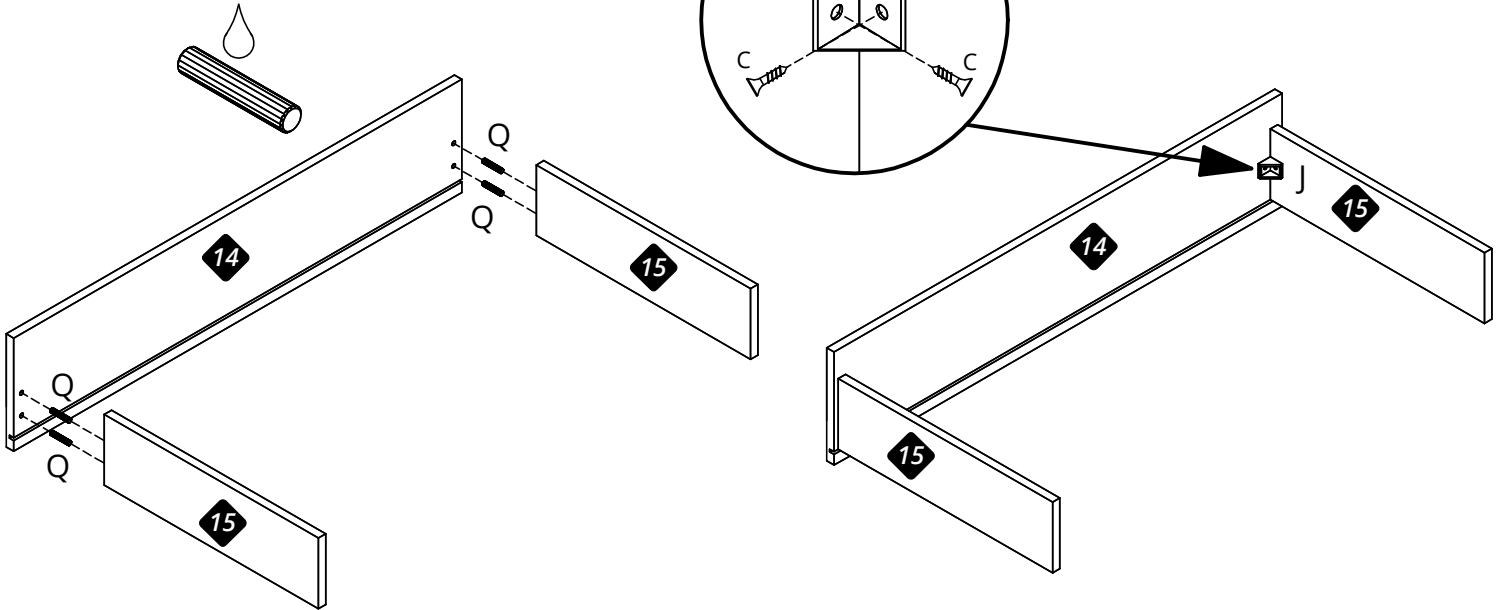

16

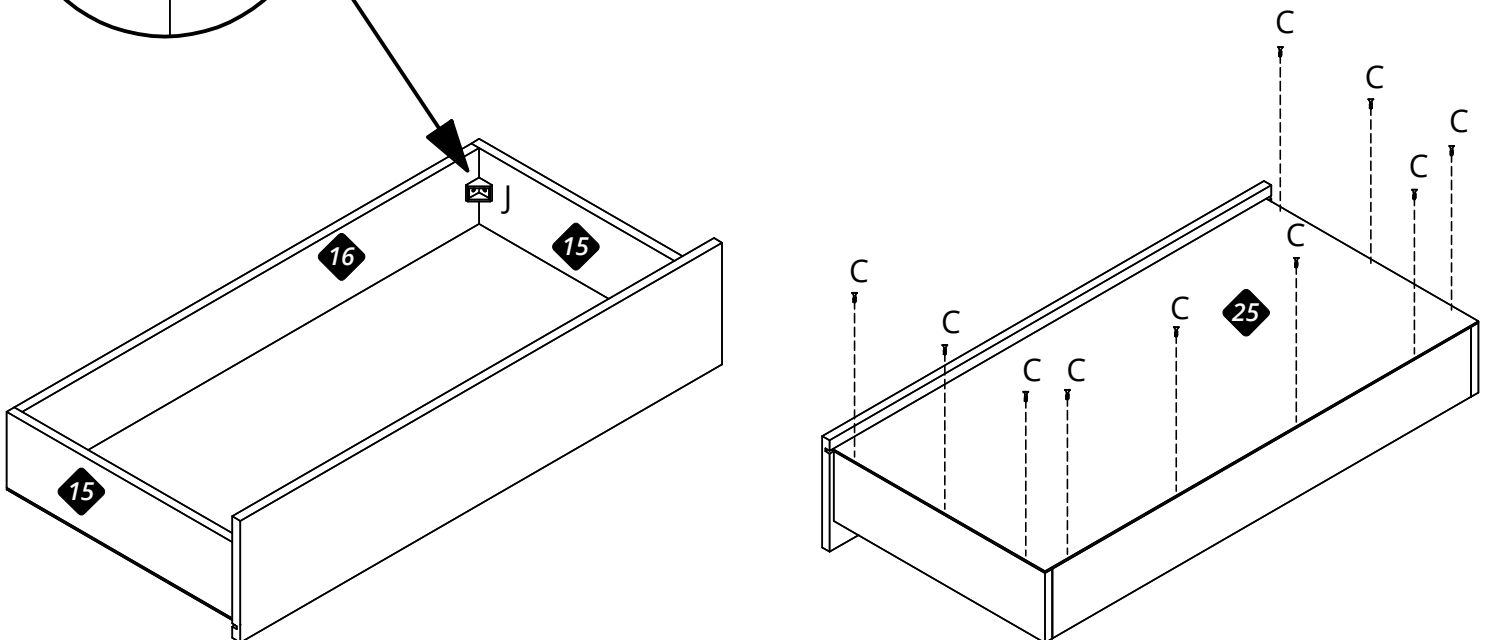
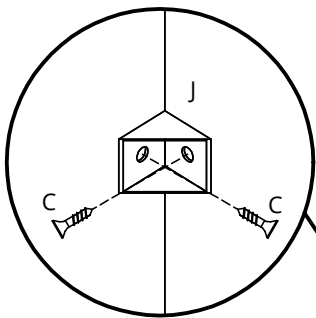
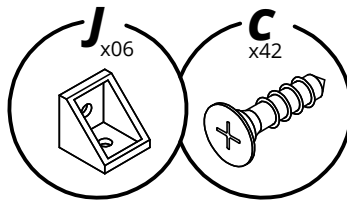

17

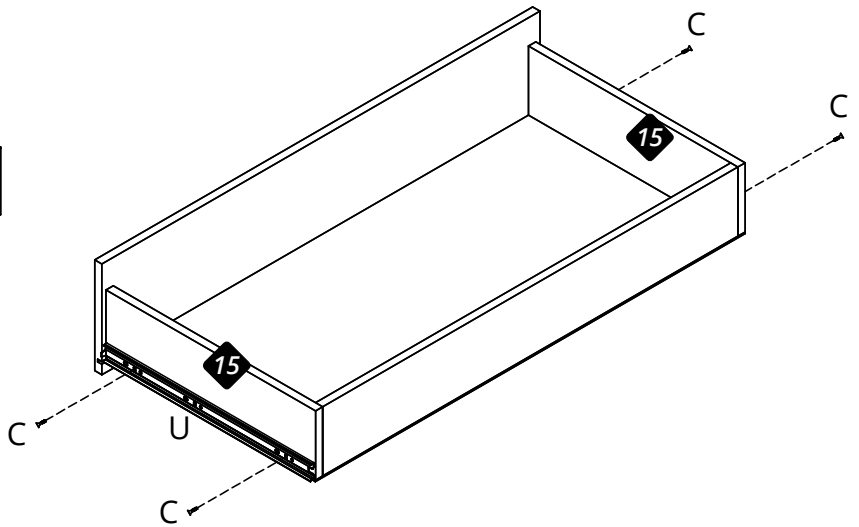
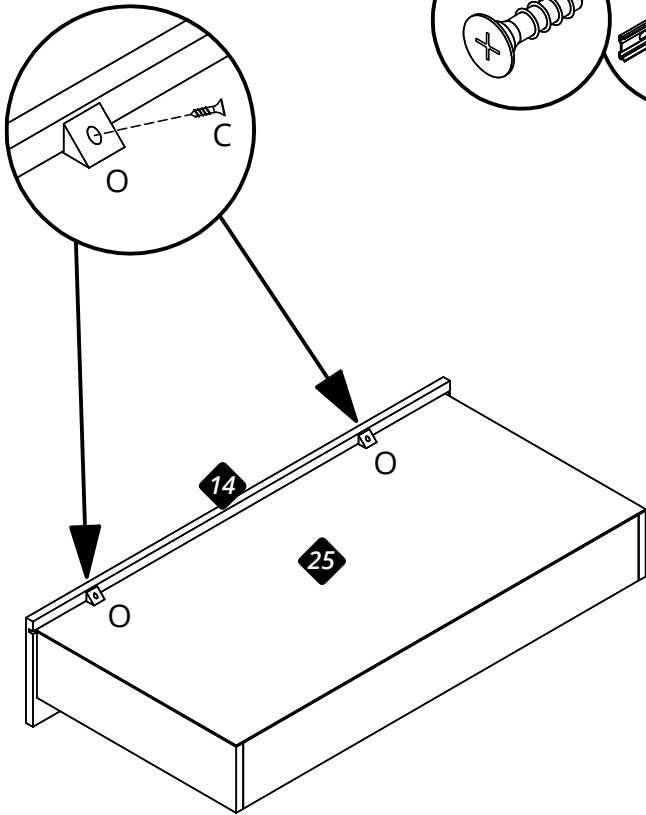
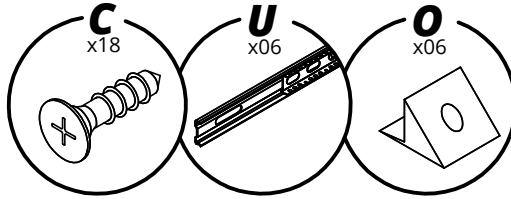

18

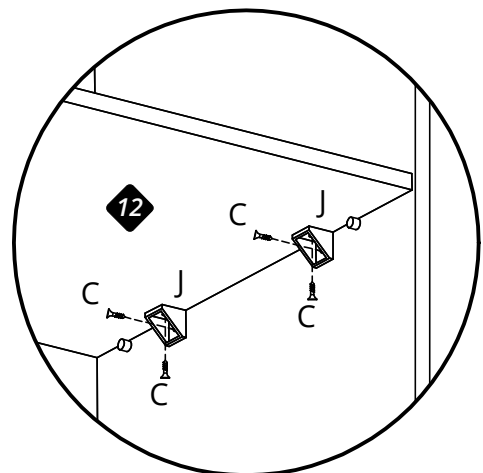
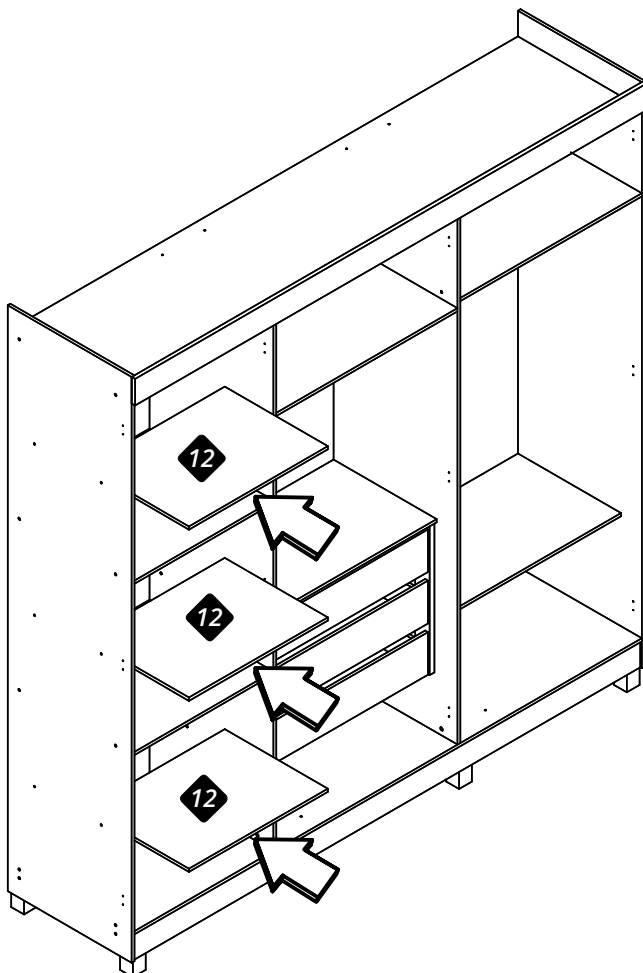
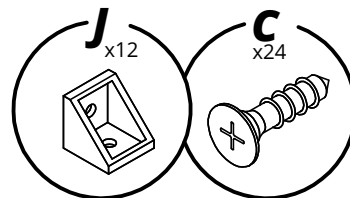

19

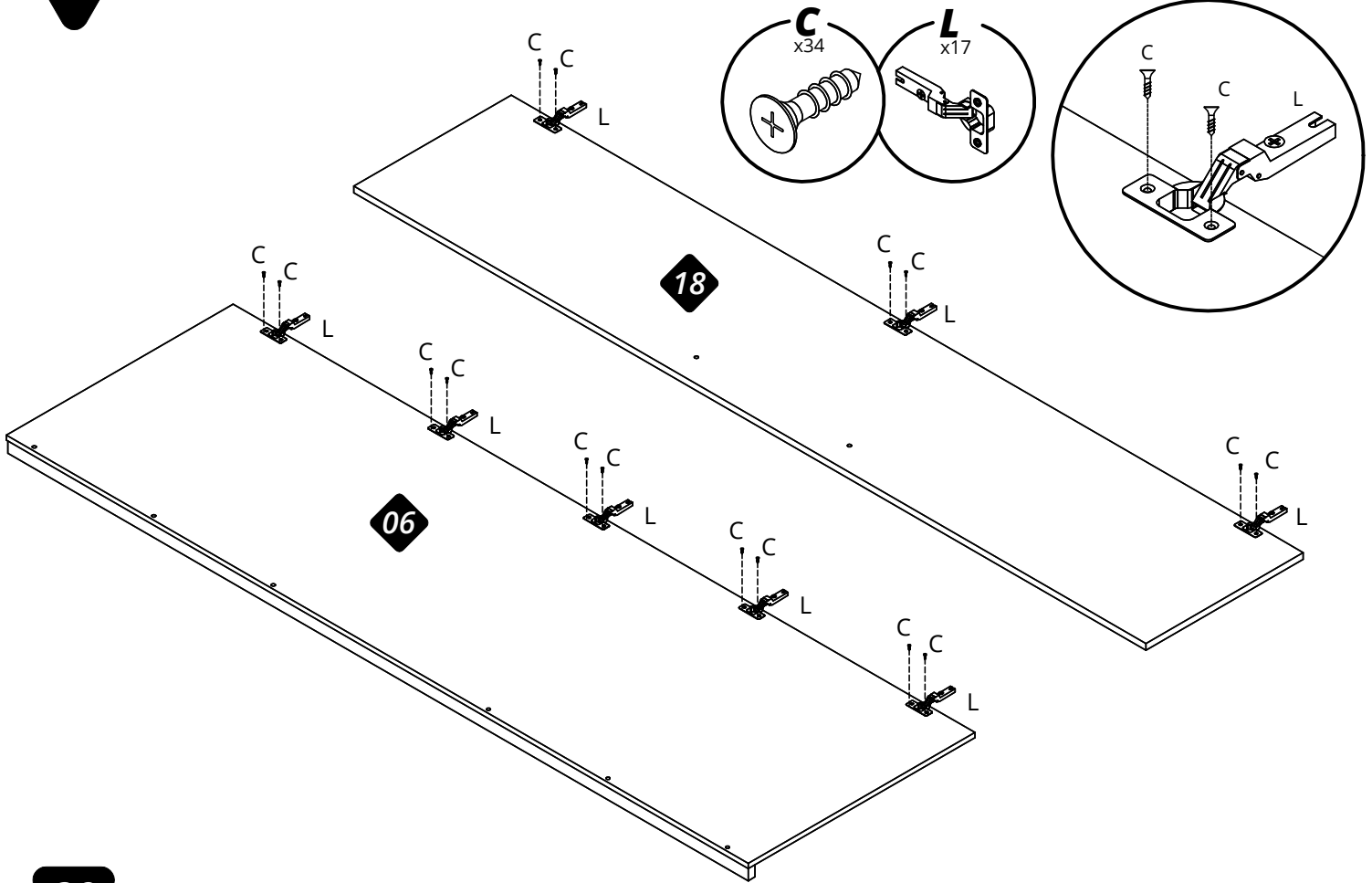

20

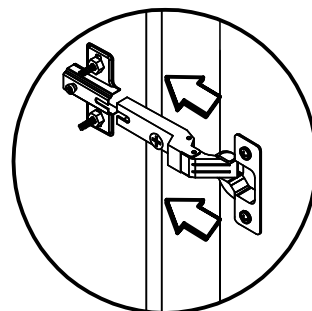
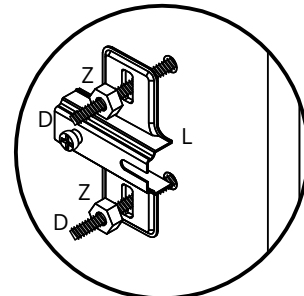
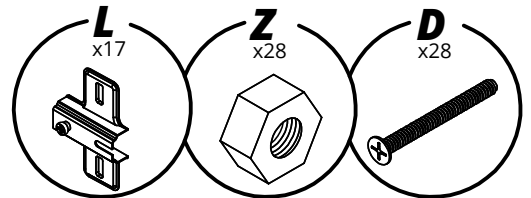
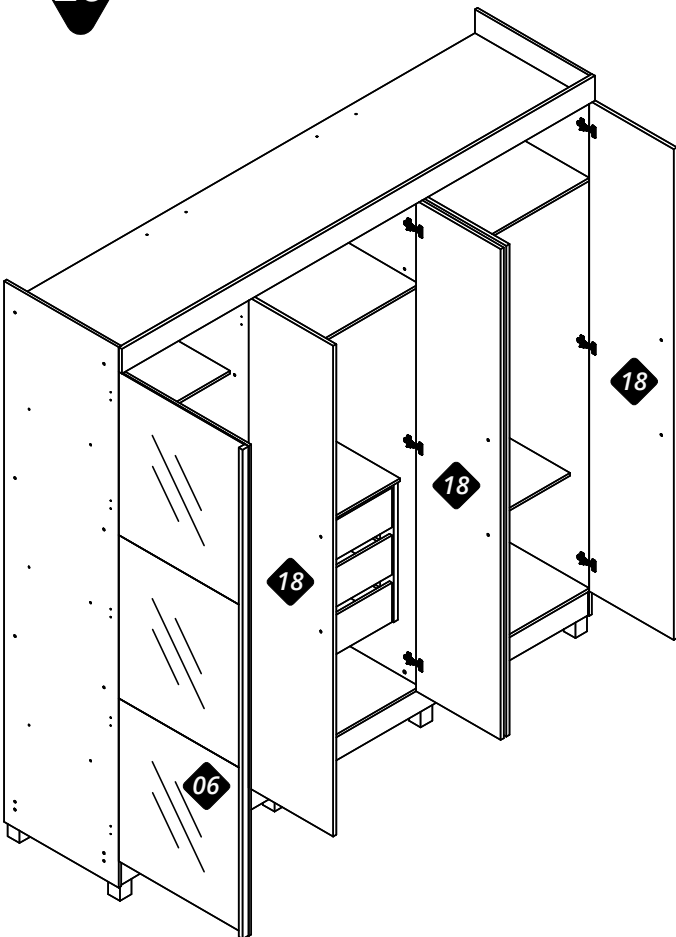

21

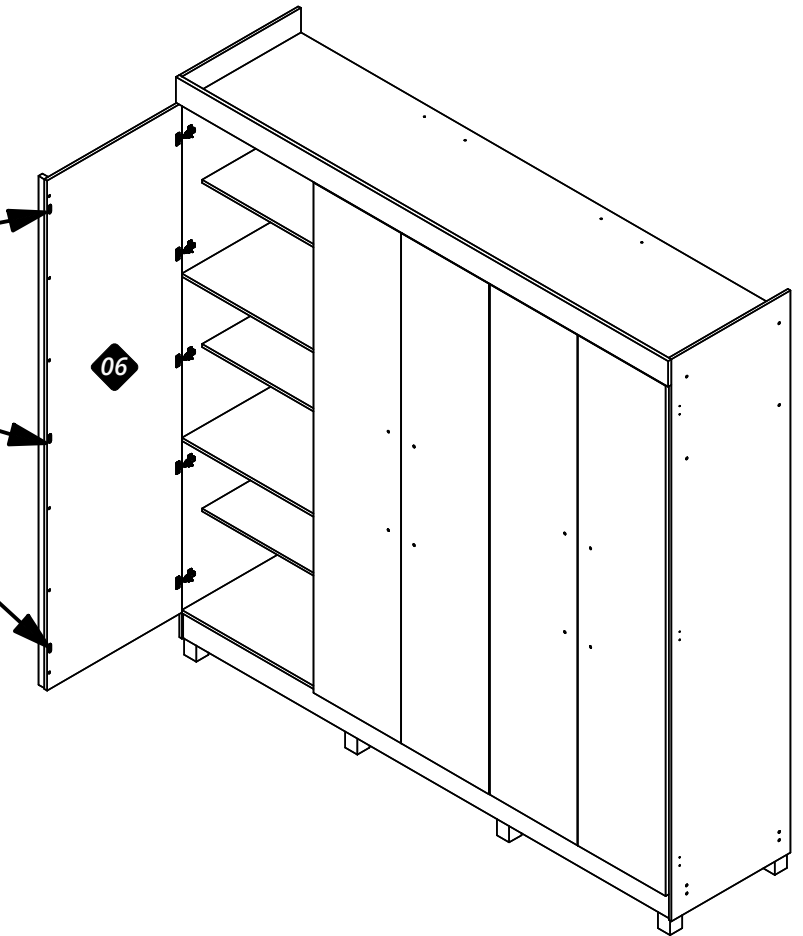
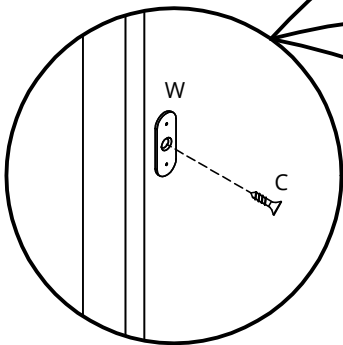
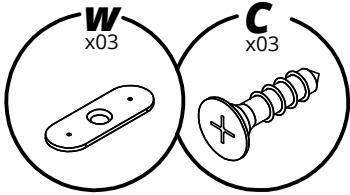

22

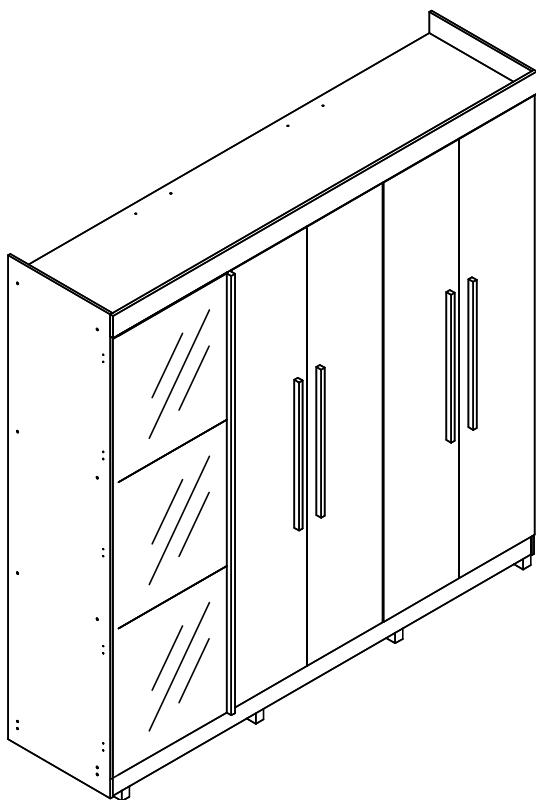

Parafuso versão Diamante

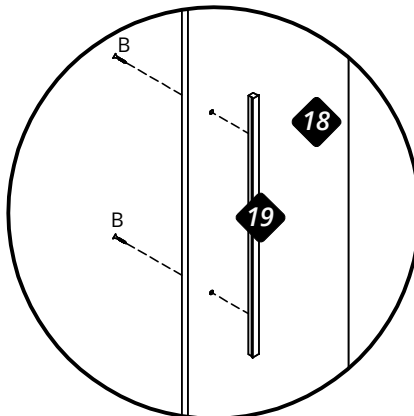
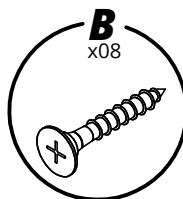

Atenção: Utilizar o parafuso que, acompanha o puxador.

Parafuso versão Diamante Plus

